



Oil and Gas Production Facilities Chapter 6, Section 2 Permitting Guidance

June 1997
Revised November 1998
Revised January 2000
Revised August 2001
Revised July 28, 2004 (specific guidance for Jonah/Pinedale Anticline Area)
Revised August 2007
Revised March 2010
Revised September 2013 (Added specific guidance for UGRB and revisions to JPAD)
Revised May 2016
Revised December 2018

Under § 35-11-801(e) of the Wyoming Environmental Quality Act, construction or modification of an oil and gas exploration or production well may occur prior to permitting, as long as the facility (1) is not a major source; (2) submits a complete permit application within 90 days of the first date of production (FDOP); and (3) applies Best Available Control Technology (BACT). However, any owner or operator may instead apply for a construction or modification permit under Chapter 6, Section 2 of the Wyoming Air Quality Standards and Regulations prior to construction or modification of a facility.

This interpretive guidance discusses the Division's current understanding of BACT for the purpose of assisting owners and operators who choose to construct or modify oil and gas production facilities prior to initiating the permitting process. This interpretive policy is not binding on the agency, the regulated community, or any person; it is for informational purposes and does not create any rights, responsibilities, or liabilities for the Division, members of the regulated community, or any other person.

Owners and operators should be advised that this Guidance represents the agency's current understanding of BACT as of August 2018.

This Guidance applies to surface oil and gas production facilities where hydrocarbon fluids are produced, processed and/or treated prior to custody transfer from the facility.

This Guidance does not apply to sour (H₂S containing) oil production sites. This Guidance also may not be used for sour gas (H₂S) production facilities unless the only emissions of H₂S will be those associated with fugitive losses from valves, fittings, surface piping and pneumatic devices, etc. If there will be H₂S emissions associated with vented gas or tank vapors or if sour gas will be flared the applicant shall contact the Division for permitting guidance prior to construction to determine BACT requirements.

This Guidance does not apply to greenhouse gas emissions (GHGs) or major sources as defined under Wyoming Air Quality Standards and Regulations Chapter 6, Section 3 or Chapter 6, Section 13.

This Guidance does not apply to reciprocating internal combustion engines located at oil and gas production facilities unless the engine is natural gas-fired, used to power a pumping unit, is less than or equal to 50 horsepower, and meets BACT. Reciprocating internal combustion engines larger than 50 horsepower are required to obtain an Air Quality Permit or Permit Waiver/Authorization Letter prior to installation.

The Presumptive BACT permitting requirements under this Guidance apply to facilities with associated wells that have a first date of production (FDOP) on/after **February 1, 2019** and to facilities with a modification occurring on/after **February 1, 2019**.

Start up or modification of a facility may occur prior to obtaining an Air Quality Permit or Waiver/Authorization Letter only when the Presumptive BACT permitting requirements under this Guidance are met. Otherwise, an Air Quality Permit or Waiver/Authorization Letter shall be obtained prior to start up or modification of a facility.

Note: The Division does not limit the amount of flaring of produced gas from a production facility. The amount/duration of produced gas flaring is requested by the operator through the Wyoming Oil and Gas Conservation Commission (WOGCC). Emissions from produced gas flaring are accounted for by the Division during the permit application review, and permit conditions are established that require the produced gas to be flared or routed to sales.

For the purposes of this Guidance **SWA (STATEWIDE AREA)** refers to all facilities not located in the **UGRB** or **JPAD/NPL**.

UGRB refers to facilities located in the **Upper Green River Basin**.

JPAD/NPL refers to facilities located in the **Jonah and Pinedale Anticline Development Area and Normally Pressured Lance**.



Table of Contents

- Introduction** 1
- Applicability** 1
 - When a permit is needed..... 1
 - Which pollutants are associated with O&G production facilities 2
- Production Facility Emission Sources**..... 2
 - O&G production facility emission sources 2
- BACT and Presumptive BACT** (what is it and when to use it) 4
- JPAD/NPL UGRB SWA** Definitions 5
- JPAD/NPL UGRB SWA** Map 6

- SWA** P-BACT permitting requirements..... 7
 - Flashing..... 7
 - Dehydration Units 8
 - Determining potential uncontrolled and potential emissions from dehydration units 9
 - Pneumatic pumps 10
 - Pneumatic controllers..... 11
 - Truck loading 11
 - Well completions 12
 - Produced water tanks 12
 - Blowdown and venting 13
 - Fugitive Emissions 13
 - Emission sources without P-BACT requirements 13

- UGRB** P-BACT permitting requirements 14
 - Flashing..... 14
 - Dehydration Units 15
 - Determining potential uncontrolled and potential emissions from dehydration units 16
 - Pneumatic pumps 16
 - Pneumatic controllers..... 16
 - Fugitive Emissions 16
 - Truck loading 17
 - Well completions 17
 - Produced water tanks 18
 - Blowdown and venting 19
 - Emission sources without P-BACT requirements 19

- JPAD/NPL** P-BACT permitting requirements..... 20
 - Flashing..... 20
 - Dehydration Units 20
 - Determining potential uncontrolled and potential emissions from dehydration units 21
 - Pneumatic pumps 21
 - Pneumatic controllers..... 21
 - Produced water tanks 22
 - Fugitive Emissions 22
 - Truck loading 23
 - Well completions 23
 - Blowdown and venting 24
 - Emission sources without P-BACT requirements 24



Table of Contents (cont.)

Determining P-BACT emissions	25
Flashing.....	25
Dehydration Units.....	27
Kimray glycol pump rates (Table 1).....	28
BACT Emission control requirements	29
Flashing emissions.....	29
Dehydration unit emissions.....	30
Sources without P-BACT emission control requirements.....	31
Permit applications	32
A complete application includes.....	32
How to obtain forms.....	33
When/where to file application.....	33
Example process diagram and description.....	34
Application review process, public notice, billing.....	36
Explanation of 0.6 decline factor	37
Pumping unit engines	38
Appendix A – Emission Calculations	39
AP-42 emission factors.....	40
Storage tank emissions (flashing, working, breathing losses).....	40
Measured Tank Flash Emissions – Example Calculations.....	41
Pressurized vessels (separator, treater, FWKO, flash separator, gunbarrel, gas boot).....	41
Dehydration units.....	41
Natural gas-fired heaters.....	42
Flares.....	43
Pneumatic pumps.....	43
Pneumatic controllers.....	44
Truck loading.....	44
Fugitive Emissions.....	45
IC pumping unit engines.....	46
Mol% to Wt% conversion.....	47
Appendix B – Definitions	48



Acronyms and Abbreviations

AQD	Air Quality Division	NESHAP	National Emission Standards for Hazardous Air Pollutants
API	American Petroleum Institute	NOI	Notice of Installation
BACT	Best Available Control Technology	NOV	Notice of Violation
BBL	barrel	NO _x	Nitrogen Oxides
BPD	barrels per day	NSPS	New Source Performance Standards
BTEX	Benzene/Toluene/ Ethyl-benzene/Xylenes	NSR	New Source Review
Btu	British thermal unit	O&G	Oil and Gas
C6 S2	Chapter 6 Section 2 (of the WAQSR)	P-BACT	Presumptive BACT
CAA	Clean Air Act	pph	pounds per hour
CO	Carbon Monoxide	PPMV	parts per million by volume
EPA	Environmental Protection Agency	PSD	Prevention of Significant Deterioration
FEM	Fugitive Emissions Monitoring	psig	pounds per square inch gauge
FWKO	Free water knockout	psia	pounds per square inch absolute
gpm	gallons per minute	SCF	standard cubic foot
H ₂ S	Hydrogen Sulfide	SO ₂	Sulfur Dioxide
HAP	Hazardous Air Pollutants	S/W/B	Standing/Working/Breathing losses
HP	high pressure	TEG	Tri-Ethylene Glycol
Hp	horsepower	TPY	Tons per Year
IMPACT	<u>I</u> nventory, <u>M</u> onitoring, <u>P</u> ermitting, <u>A</u> nd <u>C</u> ompliance <u>T</u> racking online data system	VOC	Volatile Organic Compounds
lb	pound	WAQSR	Wyoming Air Quality Standards and Regulations
LP	low pressure	WDEQ	Wyoming Department of Environmental Quality
MMBtu	one million BTUs		
MMSCF	one million standard cubic feet (SCF × 10 ⁶) (MMSCFD = 1,000,000 SCF per day)		
MSCF	one thousand standard cubic feet (SCF×1000) (MSCFD=1000 SCF per day)		



Introduction

The Oil and Gas Production Facilities Chapter 6 Section 2 Permitting Guidance (C6 S2 Guidance) document is an interpretive policy intended to publicize the Division's current understanding of BACT for certain types of emission sources at certain types of oil and gas production facilities. This interpretive policy is not binding on the agency, the regulated community, or any person; it is for informational purposes and does not create any rights, responsibilities, or liabilities for the Division, members of the regulated community, or any person. Any owners or operators seeking site-specific BACT analyses may choose to follow the standard Chapter 6, Section 2 permitting process prior to the construction or modification of a facility.



Applicability

When is a permit needed?

If **ANY** air pollutant will be released to the atmosphere from a new or modified facility, the facility is subject to the Wyoming Air Quality Standards and Regulations (**WAQSR**) and the Wyoming Environmental Quality Act. This Guidance does not apply to greenhouse gas emissions, sour oil production sites, or reciprocating internal combustion engines greater than 50 horsepower. **This Guidance may not be used for sour gas production facilities** unless the only emissions of H₂S will be those associated with fugitive losses from valves, fittings, surface piping and pneumatic devices, etc.

Owners/operators of **ALL** regulated air emission sources constructed or modified after May 29, 1974 shall comply with the WAQSR Chapter 6, Section 2 permitting requirements. To obtain a copy of the WAQSR contact the Wyoming Air Quality Division at (307) 777-7391 or download an electronic version from the Wyoming Secretary of State (<http://soswy.state.wy.us/Rules/default.aspx>). A link to the Secretary of State's website is available on the WDEQ's Air Quality website at <http://deq.wyoming.gov/aqd/>.

Under the Wyoming Environmental Quality Act, certain oil and gas production facilities may be constructed or modified prior to obtaining a permit or waiver/authorization letter, as long as they are minor sources, submit a complete permit application within 90 days of FDOP, and utilize BACT. Wyo. Stat. Ann. § 35-11-801(e).

Failure to comply with the Wyoming Environmental Quality Act and Wyoming Air Quality Regulations may result in an enforcement action undertaken by the State in the form of a "Notice of Violation", a complaint filed in District Court, or any other enforcement action allowed by law. The Wyoming Environmental Quality Act authorizes the assessment of penalties of up to \$10,000.00 per violation per day and/or injunctive relief.

Which pollutants are associated with oil and gas (O&G) production facilities?

The following air pollutants are commonly associated with O&G production facilities:

Volatile Organic Compounds (VOC): Hydrocarbon compounds excluding methane (C₁) and ethane (C₂). VOCs are also referred to as C₃⁺ compounds – propane, butane, pentane, hexane, etc.

Hazardous Air Pollutants (HAP): HAPs commonly associated with O&G production are BTEX and n-hexane (benzene, toluene, ethyl-benzene, xylenes and n-C₆). Section 112(b) of the Clean Air Act identified the regulated HAPs.

Nitrogen Oxides (NO_x): NO_x emissions are the result of natural gas combustion.

Carbon Monoxide (CO): CO emissions are the result of natural gas combustion.

Hydrogen Sulfide (H₂S): Contained within fields that produce sour gas.

Sulfur Dioxide (SO₂): Created when H₂S is combusted.



Production Facility Emission Sources

O&G production facilities emission sources:

Storage Tanks: Vapors containing regulated air pollutants are released from solution as oil, condensate and water are transferred from separation equipment to atmospheric storage tanks. These vapors are called **flashing losses**. Vapors evaporated or displaced from tanks are called **working and breathing (also called standing) losses (S/W/B)**.

Dehydration Units: Glycol, usually tri-ethylene glycol (TEG), is used in dehydration units to absorb water from wet produced gas before it is introduced into gas sales or collection lines. “Lean” TEG contacts the wet gas and absorbs water. The TEG, now considered “rich” is routed through a flash separator and/or reboiler for regeneration. Vapors released from the flash separator and reboiler still vent contain regulated air pollutants.

Pressurized Process Vessels: Vapors vented from gun barrels, separators, treaters, water knockouts, gas boots, flash separators, drip pots, etc. contain regulated air pollutants. The discharge lines and vents from all of these vessels shall be considered when determining emission sources.

Natural Gas-Fired Equipment: Some of the byproducts of natural gas combustion in process heaters, boilers, burners, flares, engines, etc. are regulated air pollutants.

Fugitives: All production facilities contain numerous equipment components such as valves, flanges, threaded connections, tubing connections, open-ended lines, pump seals, etc., which are manufactured and installed in ways intended to contain gases or liquids. Over time some of them begin to leak. Emissions associated with leaks are called fugitive emissions. For purposes of this Guidance, emissions from components that are improperly designed (e.g. enardo valves over pressurizing, failure of thief hatches to reseal after over pressurizing) or equipment not maintained properly (e.g., thief hatch left open) are not considered to be fugitive emissions.

Pneumatic Pumps & Controllers: The discharge vapors from natural gas-operated pneumatic equipment contain regulated air pollutants.

Truck Loading: Vapors displaced from truck tanks during the loading of produced liquids that contain regulated air pollutants.

Venting & Blowdown: Natural gas and liquids contain regulated air pollutants.

Well Completions: Activities that occur after a well is drilled that are undertaken to produce hydrocarbon fluids from the well. These include casing, cementing, perforating, gravel packing and installing a production tree.



BACT and Presumptive BACT

Under WAQSR Chapter 6, Section 2(c), all new or modified sources or facilities, which may generate regulated air emissions shall be permitted prior to construction or modification and **Best Available Control Technology (BACT)** shall be applied to reduce or eliminate emissions, with consideration given for technical feasibility and economical reasonableness. **BACT** is a process, not an emission limit. Regulations do not set a minimum emission threshold below which **BACT** does not need to be considered.

At O&G facilities, production rates and associated pollutant emissions are usually unknown prior to start up. The AQD has tailored a permitting program allowing for the start up or modification of O&G facilities prior to permitting provided specific emission control requirements are met. This is the **Presumptive BACT** permitting process for O&G production facilities.

Presumptive BACT requirements have been established for emissions associated with:

- Flashing & S/W/B losses from atmospheric storage tanks and pressurized vessels (including produced gas venting/flaring)
- Dehydration unit process vents
- Natural gas-operated pneumatic equipment
- Natural gas-fired pumping unit engines
- Truck loading
- Produced water tanks
- Well completions
- Well blowdown/venting
- Fugitive Emissions

If emissions **are known prior to** construction or modification, a permit shall be obtained **PRIOR TO CONSTRUCTION or MODIFICATION** and BACT, including Presumptive BACT requirements, shall be addressed in the application. Examples include:

- Construction of a central tank battery for collecting and processing production from surrounding existing wells with known production rates
- Consolidation of multiple existing facilities for which production rates have been established
- Installation of a dehydration unit for an existing well with an established gas production rate
- Installation of larger capacity equipment to replace undersized equipment
- Replacement of an emission control system or device with a different system or device

Presumptive BACT requirements have been established for three (3) areas:

SWA refers to all facilities not located in the **UGRB** or **JPAD/NPL**.

UGRB refers to facilities located in the **Upper Green River Basin**.

JPAD/NPL refers to facilities located in the **Jonah and Pinedale Anticline Development Area and Normally Pressured Lance**.

The **UGRB** area is defined, in accordance with the public land survey system, as:

Sublette County: (all)

Lincoln County: (part) The area of the county north and east of the boundary defined by a line starting at the point defined by the intersection of the southwest corner Section 30 Range (R) 115 West (R115W) Township (T) 27 North (T27N) and the northwest corner of Section 31 R115W T27N of Sublette County at Sublette County's border with Lincoln County. From this point the boundary moves to the west 500 feet to the Aspen Creek. The boundary follows the centerline of Aspen Creek downstream to the confluence of Aspen Creek and Fontenelle Creek (in R 116 W T26N Section 1). From this point the boundary moves generally to the south along the centerline of Fontenelle Creek to the confluence of Fontenelle Creek and Roney Creek (in R115W T24N Section 6). From the confluence, the boundary moves generally to the east along the centerline of Fontenelle Creek and into the Fontenelle Reservoir (in R112W T24N Section 6). The boundary moves east southeast along the centerline of the Fontenelle Reservoir and then toward the south along the centerline of the Green River to where the Green River in R111W T24N Section 31 crosses into Sweetwater County.

Sweetwater County: (part) The area of the county west and north of the boundary, which begins at the midpoint of the Green River, where the Green River enters Sweetwater County from Lincoln County in R111W T24N Section 31. From this point, the boundary follows the center of the channel of the Green River generally to the south and east to the confluence of the Green River and the Big Sandy River (in R109W T22N Section 28). From this point, the boundary moves generally north and east along the centerline of the Big Sandy River to the confluence of the Big Sandy River with Little Sandy Creek (in R106W T25N Section 33). The boundary continues generally toward the northeast along the centerline of Little Sandy Creek to the confluence of Little Sandy Creek and Pacific Creek (in R106W T25N Section 24). From this point, the boundary moves generally to the east and north along the centerline of Pacific Creek to the confluence of Pacific Creek and Whitehorse Creek (in R103W T26N Section 10). From this point the boundary follows the centerline of Whitehorse Creek generally to the northeast until it reaches the eastern boundary of Section 1 R103W T26N. From the point where Whitehorse Creek crosses the eastern section line of Section 1 R103W T26N, the boundary moves straight north along the section line to the southeast corner of Section 36 R103W T27N in Sublette County where the boundary ends.

The **JPAD/NPL** area is defined as:

Sublette County: R109W & R110W in T34N,
R109W & R110W in T33N,
R108W, R109W & R110W in T32N,
R108W, R109W & R110W in T31N,
R107W, R108W & R109W in T30N,
R107W, R108W, R109W, & R110W in T29N,
R107W, R108W, R109W, & R110W in T28N,
and R107W, R108W & R109W in T27N

The **SWA** refers to all other areas in the State excluding the **UGRB** or **JPAD/NPL**.



Presumptive BACT Requirements for SWA Facilities

Flashing and S/W/B

For the purpose of determining flashing and S/W/B emissions all vapor streams containing VOC and/or HAP components from all storage tanks (e.g., oil, condensate, produced water with oil or condensate carryover) and all separation vessels (e.g., gun barrels, production and test separators, production and test treaters, water knockouts, gas boots, flash separators, drip pots, etc.) at a facility, which are or may be vented to the atmosphere shall be considered.

New Facilities

PAD Facilities

Upon First Date of Production (FDOP), VOC and HAP flashing and S/W/B emissions shall be controlled by at least 98%.

Single Well Facilities and Tank Batteries

Within 60 days of FDOP, flashing and S/W/B emissions containing greater than or equal to 6 Tons per Year (TPY) VOC and HAPs shall be controlled by at least 98%.

Modified Facilities

The following requirements apply to an existing facility that has production streams or production equipment associated with another well or wells added to or tied into it. For other modifications, see the definition of modified facility on page 50 for control requirements.

PAD Facilities

Upon modification, all new and existing VOC and HAP flashing and S/W/B emissions shall be controlled by at least 98%.

Single Well Facilities and Tank Batteries

Within 60 days of modification, all new and existing flashing and S/W/B emissions containing greater than or equal to 6 TPY VOC and HAPs shall be controlled by at least 98%.

New and Modified Facilities

Condensate and oil tanks that are on site solely for use during emergency or upset conditions, such as spare tanks at facilities connected to liquids gathering systems, are not subject to the 98% control requirements.

The removal of a flashing emissions control device(s) may be allowed upon approval if, after at least one year from the date of installation, VOC and HAP flashing emissions have declined to less than, and are reasonably expected to remain below 4 TPY of VOC and HAPs.

****Note:** if produced gas is not sold, uncontrolled VOC and HAP emissions associated with the produced gas shall be included with tank flashing and S/W/B emissions to determine control requirements.



Presumptive BACT Requirements for SWA Facilities (cont.)

Dehydration Units

For the purpose of determining emissions from dehydration units, vapor streams containing VOC or HAP components released from the process vents (reboiler still vents & glycol flash separator vents) of all dehydration units at a facility, which are or may be vented to the atmosphere shall be considered. See page 9 for the definitions of **potential uncontrolled** VOC and HAP emissions and **potential** VOC and HAP emissions.

New Facilities

Upon FDOP, all dehydration units shall be equipped with reboiler still vent condensers. Removal of the condensers will not be allowed.

PAD Facilities

Upon FDOP, all dehydration unit VOC and HAP emissions shall be controlled by at least 98%. After one year, combustion units used to achieve the 98% control may be removed upon approval if

- Total **potential** VOC and HAP emissions from all units are less than 4 TPY and
- All units are equipped with still vent condensers.

Single Well Facilities

Within 60 days of FDOP, if total **potential uncontrolled** VOC and HAP emissions from all units are greater than or equal to 6 TPY, emissions from all units shall be controlled by at least 98%.

After one year, combustion units used to achieve the 98% control may be removed upon approval if

- Total **potential** VOC and HAP emissions from all units are less than 4 TPY and
- All units are equipped with still vent condensers.

Modified Facilities

The following requirements apply to an existing facility that has production streams or production equipment associated with another well or wells added to or tied into it. For other modifications, see the definition of modified facility on page 50 for control requirements.

Requirements are the same as those for PADs and single well facilities except use the date of modification in place of FDOP. Control requirements apply to all existing and new dehydration units.



Presumptive BACT Requirements for SWA Facilities (cont.)

All Facilities

When a combustion unit is required at a facility for control of dehydration unit emissions, all non-condensable still vent vapors shall be collected and routed to a combustion unit for at least 98% control of VOC and HAP emissions. All glycol flash separator vapors shall be collected and routed to the combustion unit for at least 98% control of VOC and HAP emissions and/or used as fuel for process equipment burners.

At facilities where a combustion unit is not required for control of flash or dehydration unit emissions, all glycol flash separator vapors shall be collected for use as fuel in process equipment burners. Excess flash vapors that are not used as fuel may be vented to the atmosphere.

Potential Uncontrolled VOC and HAPs emissions shall be determined using GRI-GLYCalc version 4.0 (V4.0) or higher or other method accepted by the Division and shall be based on the projected, year one, average daily dry gas throughput rate, maximum circulation rate for the glycol circulation pump(s) installed, average expected operating parameters for wet gas temperature and pressure, maximum dry gas water content or number of absorber stages and extended hydrocarbon content of the wet gas from a sample of the wet gas taken upstream of the dehydration unit contact tower. Flash separators, still vent condensers, limited operating hours, and limited glycol circulation rates shall not be considered when determining potential uncontrolled emissions.

Still vent condensers shall consist of equipment engineered and designed to achieve maximum condensation of the condensable components in the still vent vapors by providing adequate temperature differentials between the condenser outlet and still vent stream. Still vent pipes shall not be considered condensers.

Potential emissions for determining combustion device removal after one year shall be calculated using GRI-GLYCalc V4.0 or higher or other method accepted by the Division based on the past twelve calendar months of normal gas production rates, actual average wet gas temperature and pressure, actual water content of the dried gas or number of absorber stages.

Actual operating parameters for glycol flash separators may be used upon approval. Limited operating hours and limited glycol circulation rates shall not be considered for control removal.



Presumptive BACT Requirements for SWA Facilities (cont.)

Pneumatic Pumps

New Facilities

PAD Facilities

Upon FDOP, VOC and HAP emissions associated with the discharge streams of all natural gas-operated pneumatic pumps shall be controlled by at least 98% or the pump discharge streams shall be routed into a closed loop system (e.g., sales line, collection line, fuel supply line).

Single Well Facilities and Tank Batteries

Within 60 days of FDOP,

At sites with controls installed for flashing or dehydration unit emissions:

VOC and HAP emissions associated with the discharge streams from natural gas-operated pneumatic pumps shall be controlled by at least 98% or the discharge streams shall be routed into a closed loop system.

At sites without controls installed for flashing or dehydration unit emissions:

Pneumatic pumps (other than heat trace/heat medium/hot glycol circulation) shall be solar, electric or air-driven pumps in lieu of natural gas-operated pneumatic pumps or the discharge streams shall be routed into a closed loop system. Wherever possible, heat trace/heat medium/hot glycol circulation pumps shall be solar-operated, electric or air-driven.

Modified Facilities

Requirements are the same as above except include all new and existing pneumatic pumps and use the date of modification in place of FDOP.

New and Modified Facilities

At sites where pneumatic pump emissions are controlled by a combustion unit used for the control of flashing or dehydration unit emissions, control of the pneumatic pump emissions will be evaluated upon request for removal of the combustion unit. (See Flashing, Page 7)



Presumptive BACT Requirements for SWA Facilities (cont.)

Pneumatic Controllers

New Facilities

Upon FDOP, natural gas-operated pneumatic controllers shall be low bleed, intermittent bleed, or zero bleed controllers or the controller discharge streams shall be routed into a closed loop system.

Modified Facilities

Upon modification, new natural gas-operated pneumatic controllers shall be low, intermittent, or zero bleed controllers or the controller discharge streams shall be routed into a closed loop system.

Within 60 days of modification, existing natural gas-operated pneumatic controllers shall be replaced by or converted to low, intermittent, or zero bleed controllers or the discharge streams of existing natural gas-operated pneumatic controllers shall be routed into a closed loop system.

Truck Loading

New Facilities

Within 60 days of FDOP, loading emissions containing greater than or equal to 6 TPY VOC and HAP emissions shall be controlled. Operators are expected to utilize a vapor collection system or equivalent device for the truck loading operation that is assumed, based on AP-42 Section 5.2, to capture a minimum of 70% of the truck loading vapors. The captured vapors are to be routed to a smokeless combustion device with a reported destruction efficiency of 98%, or routed to an equivalent control.

Modified Facilities

Upon modification, all new and existing VOC and HAP loading emissions containing greater than or equal to 6 TPY VOC and HAP emissions shall be controlled. Operators are expected to utilize a vapor collection system or equivalent device for the truck loading operation that is assumed, based on AP-42 Section 5.2, to capture a minimum of 70% of the truck loading vapors. The captured vapors are to be routed to a smokeless combustion device with a reported destruction efficiency of 98%, or routed to an equivalent control.

New and Modified Facilities

The removal of a control device(s) may be allowed upon approval if after at least one year from the date of installation VOC and HAP loading emissions have declined to less than, and are expected to remain below 4 TPY of VOC and HAPs.

Note: Safety issues associated with the control of truck loading emissions will be taken into consideration by the Division. Applicants will be required to demonstrate that safety issues would preclude the application of controls, and the demonstration will have to be approved by the Division prior to the date that controls would be required under the Guidance.



Presumptive BACT Requirements for SWA Facilities (cont.)

Well Completions

Operators shall submit applications to perform well completions using Best Management Practices. One permit will be issued to each company that drills and completes wells within the State. An example of a well completions or “Green Completions” permit is available on the AQD website, <http://deq.wyoming.gov/aqd/new-source-review> or a copy may be obtained by contacting the Wyoming Air Quality Division at (307) 777-7391.

For new operators, a Green Completion permit application shall be filed with the first application for a production site.

Produced Water Tanks

New Facilities

PAD Facilities

Upon FDOP, VOC and HAP emissions from all active produced water tanks shall be controlled by at least 98%.

Single Well Facilities and Tank Batteries

Within 60 days of FDOP, at sites where flashing and S/W/B emissions must be controlled by at least 98%, VOC and HAP emissions from all active produced water tanks shall be controlled by at least 98%.

Modified Facilities

PAD Facilities

Upon modification, VOC and HAP emissions from all new active produced water tanks shall be controlled by at least 98%.

Within 60 days of modification, existing open-top, active, produced water tanks shall be taken out of service for use as active produced water tanks. All active produced water tanks shall be closed top and shall have VOC and HAP emissions controlled by at least 98%.

Single Well Facilities and Tank Batteries

Within 60 days of modification, at sites where flashing and S/W/B emissions must be controlled by at least 98%, VOC and HAP emissions from all active produced water tanks shall be controlled by at least 98%.

Within 60 days of modification, existing open-top, active, produced water tanks shall be taken out of service for use as active produced water tanks. All active produced water tanks shall be closed top and shall have VOC and HAP emissions controlled by at least 98%.



Presumptive BACT Requirements for SWA Facilities (cont.)

New and Modified Facilities

Produced water tanks that are on site solely for use during emergency or upset conditions, such as spare tanks at facilities connected to liquids gathering systems, are not subject to the 98% control requirements.

The removal of a emissions control device(s) may be allowed upon approval if, after at least one year from the date of installation, VOC and HAP flashing emissions have declined to less than, and are reasonably expected to remain below 4 TPY of VOC and HAPs.

Blowdown/Venting

Best Management Practices (BMP) and information gathering requirements for new and modified facilities.

BMP: During manual and automated blowdown/venting episodes associated with liquids unloading, wellbore depressurization in preparation for maintenance or repair, hydrate clearing, emergency operations, equipment depressurization, etc., associated VOC and HAP emissions shall be minimized to the extent practicable. During manual blowdown or venting, personnel shall remain on site to ensure minimal gas venting occurs.

Information Gathering: Specific recordkeeping and reporting requirements will be established during the permitting process and will include estimates of associated regulated air pollutants, reasons for episodes, durations of episodes, steps taken to minimize emissions and descriptions of emission estimation methods.

For new operators, a well blowdown and venting permit application shall be filed with the first application for a production site.

Fugitive Emissions

New Facilities

Upon FDOP, for fugitive VOC emissions from a production site, operators shall follow the semi-annual monitoring frequency in 40 CFR part 60, Subpart OOOOa (as published in the federal register on June 3, 2016 [Federal Register Vol. 81 pg. 35824-35941]). Use of an alternative method for monitoring fugitives may be allowed upon Division approval.

Modified Facilities

Upon modification, for fugitive VOC emissions from a production site, operators shall follow the semi-annual monitoring frequency in 40 CFR part 60, Subpart OOOOa (as published in the federal register on June 3, 2016 [Federal Register Vol. 81 pg. 35824-35941]). Use of an alternative method for monitoring fugitives may be allowed upon Division approval.

Emission Sources without Presumptive BACT requirements

For uncontrolled sources emitting greater than or equal to 6 TPY VOC and HAP emissions, that do not have P-BACT requirements, a BACT analysis shall be filed with the permit application for the associated facility.



Presumptive BACT Requirements for UGRB Facilities

Flashing

For the purpose of determining flashing and S/W/B emissions all vapor streams containing VOC or HAP components from all storage tanks (e.g., oil, condensate, produced water with oil or condensate carryover) and all separation vessels (e.g., gun barrels, production and test separators, production and test treaters, water knockouts, gas boots, flash separators, drip pots, etc.) at a facility, which are or may be vented to the atmosphere shall be considered.

New Facilities

PAD Facilities

Upon FDOP, VOC and HAP flashing and S/W/B emissions shall be controlled by at least 98%.

Single Well Facilities and Tank Batteries

Within 60 days of FDOP, flashing and S/W/B emissions containing greater than or equal to 4 TPY VOC and HAPs shall be controlled by at least 98%.

Modified Facilities

Upon modification, all new and existing VOC and HAP flashing and S/W/B emissions shall be controlled by at least 98%.

Single Well Facilities and Tank Batteries

Within 60 days of modification, all new and existing flashing and S/W/B emissions containing greater than or equal to 4 TPY VOC and HAPs shall be controlled by at least 98%.

New and Modified Facilities

Condensate and oil tanks that are on site for use during emergency or upset conditions, such as spare tanks at facilities connected to liquids gathering systems, are not subject to the 98% control requirements.

The removal of flashing emissions control devices may be allowed upon approval after one year if VOC flashing emissions have declined to less than, and are reasonably expected to remain below 4 TPY.

****Note:** if produced gas is not sold, uncontrolled VOC and HAP emissions associated with the produced gas shall be included with tank flashing and S/W/B emissions to determine control requirements.



Presumptive BACT Requirements for UGRB Facilities (cont.)

Dehydration Units

For the purpose of determining emissions from dehydration units, vapor streams containing VOC or HAP components released from the process vents (reboiler still vents & glycol flash separator vents) of all dehydration units at a facility, which are or may be vented to the atmosphere shall be considered. See page 9 for the definitions of **potential uncontrolled** VOC and HAP emissions and **potential** VOC and HAP emissions.

New Facilities

Upon FDOP, all dehydration units shall be equipped with reboiler still vent condensers. Removal of the condensers will not be allowed.

PAD Facilities

Upon FDOP, all dehydration unit VOC and HAP emissions shall be controlled by at least 98%. After one year, combustion units used to achieve the 98% control may be removed upon approval if

- Total **potential** VOC and HAP emissions from all units are less than 4 TPY and
- All units are equipped with still vent condensers.

Single Well Facilities

Within 60 days of FDOP, if total **potential uncontrolled** VOC and HAP emissions from all units are greater than or equal to 4 TPY, emissions from all units shall be controlled by at least 98%.

After one year, combustion units used to achieve the 98% control may be removed upon approval if

- Total **potential** VOC and HAP emissions from all units are less than 4 TPY and
- All units are equipped with still vent condensers.

Modified Facilities

Requirements are the same as those for PADs and single well facilities except use the date of modification in place of FDOP. Control requirements apply to existing and new dehydration units.

All Facilities

When a combustion unit is required at a facility for control of flash or dehydration unit emissions, all non-condensable still vent vapors shall be collected and routed to the combustion unit for at least 98% control of VOC and HAP emissions and all glycol flash separator vapors shall be collected and routed to the combustion unit for at least 98% control of VOC and HAP emissions and/or used as fuel for process equipment burners.

At facilities where a combustion unit is not required for control of flash or dehydration unit emissions, all glycol flash separator vapors shall be collected for use as fuel in process equipment burners. Excess flash vapors that are not used as fuel may be vented to the atmosphere.



Presumptive BACT Requirements for UGRB Facilities (cont.)

Pneumatic Pumps

New Facilities

Upon FDOP, VOC and HAP emissions associated with the discharge streams of all natural gas-operated pneumatic pumps shall be controlled by at least 98% or the pump discharge streams shall be routed into a closed loop system (e.g., sales line, collection line, fuel supply line).

Modified Facilities

Upon modification, VOC and HAP emissions associated with the discharge streams of all new and existing natural gas-operated pneumatic pumps shall be controlled by at least 98% or the pump discharge streams shall be routed into a closed loop system.

New and Modified Facilities

At sites where pneumatic pump emissions are controlled by a combustion unit used for the control of flash or dehydration unit emissions, control of the pneumatic pump emissions will be evaluated upon request for removal of the combustion unit. (See Flashing, Page 14)

Pneumatic Controllers

New Facilities

Upon FDOP, natural gas-operated pneumatic controllers shall be low, intermittent, or zero bleed controllers or the controller discharge streams shall be routed into a closed loop system.

Modified Facilities

Upon modification, new natural gas-operated pneumatic controllers shall be low, intermittent, or zero bleed controllers or the controller discharge streams shall be routed into a closed loop system.

Within 60 days of modification, existing natural gas-operated pneumatic controllers shall be replaced by or converted to low, intermittent, or zero bleed controllers or the discharge streams of existing natural gas-operated pneumatic controllers shall be routed into a closed loop system.

Fugitive Emissions

New Facilities

Upon FDOP, for fugitive VOC emissions from a production site that are less than 4 TPY, operators shall follow the semi-annual monitoring frequency in 40 CFR part 60, Subpart OOOOa (as published in the federal register on June 3, 2016 [Federal Register Vol. 81 pg. 35824-35941]). Use of an alternative method for monitoring fugitives may be allowed upon Division approval.

Modified Facilities

Upon modification, for fugitive VOC emissions from a production site that are less than 4 TPY, operators shall follow the semi-annual monitoring frequency in 40 CFR part 60, Subpart OOOOa (as published in the federal register on June 3, 2016 [Federal Register Vol. 81 pg. 35824-35941]). Use of an alternative method for monitoring fugitives may be allowed upon Division approval.



Presumptive BACT Requirements for UGRB Facilities (cont.)

For new and modified facilities where fugitive emissions are greater than or equal to 4 TPY of VOCs, operators shall submit a Fugitive Emissions Monitoring (FEM) Protocol. The fugitive emission monitoring in the FEM Protocol shall be no less frequent than quarterly, and may consist of Method 21, infrared camera, audio-visual-olfactory (AVO) inspections, or some combination thereof and must be approved by the Division. A proposed FEM Protocol consisting of only AVO inspections will not be accepted by the Division.

Truck Loading

New Facilities

Within 60 days of FDOP, loading emissions containing greater than or equal to 6 TPY VOC and HAP emissions shall be controlled. Operators are expected to utilize a vapor collection system or equivalent device for the truck loading operation that is assumed, based on AP-42 Section 5.2, to capture a minimum of 70% of the truck loading vapors. The captured vapors are to be routed to a smokeless combustion device with a reported destruction efficiency of 98%, or routed to an equivalent control.

Modified Facilities

Upon modification, all new and existing VOC and HAP loading emissions containing greater than or equal to 6 TPY VOC and HAP emissions shall be controlled. Operators are expected to utilize a vapor collection system or equivalent device for the truck loading operation that is assumed, based on AP-42 Section 5.2, to capture a minimum of 70% of the truck loading vapors. The captured vapors are to be routed to a smokeless combustion device with a reported destruction efficiency of 98%, or routed to an equivalent control.

New and Modified Facilities

The removal of a control device(s) may be allowed upon approval if after at least one year from the date of installation VOC and HAP loading emissions have declined to less than, and are expected to remain below 4 TPY of VOC and HAPs.

Note: Safety issues associated with the control of truck loading emissions will be taken into consideration by the Division. Applicants will be required to demonstrate that safety issues would preclude the application of controls, and the demonstration will have to be approved by the Division prior to the date that controls would be required under the Guidance.

Well Completions

Operators shall submit applications to perform well completions using Best Management Practices. One permit will be issued to each company that drills and completes wells within the **UGRB**. The permits will be modeled after those issued to operators completing wells in the Jonah and Pinedale Anticline Development Area. An example of a well completions or “Green Completions” permit is available on the AQD website, <http://deq.wyoming.gov/aqd/new-source-review> or a copy may be obtained by contacting the Wyoming Air Quality Division at (307) 777-7391.



Presumptive BACT Requirements for UGRB Facilities (cont.)

Produced Water Tanks

New Facilities

PAD Facilities

Upon FDOP, VOC and HAP emissions from all active produced water tanks shall be controlled by at least 98%.

Single Well Facilities and Tank Batteries

Within 60 days of FDOP, at sites where flashing and S/W/B emissions must be controlled by at least 98%, VOC and HAP emissions from all active produced water tanks shall be controlled by at least 98%.

Modified Facilities

PAD Facilities

Upon modification, VOC and HAP emissions from all new active produced water tanks shall be controlled by at least 98%.

Within 60 days of modification, existing open-top, active, produced water tanks shall be taken out of service for use as active produced water tanks. All active produced water tanks shall be closed top and shall have VOC and HAP emissions controlled by at least 98%.

Single Well Facilities and Tank Batteries

Within 60 days of modification, at sites where flashing and S/W/B emissions must be controlled by at least 98%, VOC and HAP emissions from all active produced water tanks shall be controlled by at least 98%.

Within 60 days of modification, existing open-top, active, produced water tanks shall be taken out of service for use as active produced water tanks. All active produced water tanks shall be closed top and shall have VOC and HAP emissions controlled by at least 98%.

New and Modified Facilities

Open-top or blow down tanks shall not be used as active produced water tanks but may be used for blow down or for temporary storage during emergency or upset conditions, such as spare tanks at facilities connected to liquids gathering systems, and do not have to be tied into 98% control systems.

Removal of produced water tank emissions control may be allowed upon approval. (See Flashing, Page 14)



Presumptive BACT Requirements for UGRB Facilities (cont.)

Blowdown/Venting

Best Management Practices (BMP) and information gathering requirements will be incorporated into permits for new and modified facilities.

BMP: During manual and automated blowdown/venting episodes associated with liquids unloading, wellbore depressurization in preparation for maintenance or repair, hydrate clearing, emergency operations, equipment depressurization, etc., associated VOC and HAP emissions shall be minimized to the extent practicable. During manual blowdown or venting, personnel shall remain on site to ensure minimal gas venting occurs.

Information Gathering: Specific recordkeeping and reporting requirements will be established during the permitting process and will include estimates of associated regulated air pollutants, reasons for episodes, durations of episodes, steps taken to minimize emissions and descriptions of emission estimation methods.

Emission Sources without Presumptive BACT requirements

For uncontrolled sources emitting greater than or equal to 4 TPY VOC that do not have P-BACT requirements, a BACT analysis shall be filed with the permit application for the associated facility.



Presumptive BACT Requirements for JPAD/NPL Facilities

Flashing

For the purpose of determining flashing and S/W/B emissions all vapor streams containing VOC or HAP components from all storage tanks (e.g., oil, condensate, produced water with oil or condensate carryover) and all separation vessels (e.g., gun barrels, production and test separators, production and test treaters, water knockouts, gas boots, flash separators, drip pots, etc.) at a facility, which are or may be vented to the atmosphere shall be considered.

New Facilities

Upon FDOP, VOC and HAP flashing and S/W/B emissions shall be controlled by at least 98%.

Modified Facilities

Upon modification, all new and existing VOC and HAP flashing and S/W/B emissions shall be controlled by at least 98%.

New and Modified Facilities

Condensate and oil tanks that are on site for use during emergency or upset conditions, such as spare tanks at facilities connected to liquids gathering systems, are not subject to the 98% control requirements.

The removal of flashing emissions control devices may be allowed upon approval after one year if VOC and HAP flashing emissions have declined to less than, and are reasonably expected to remain below 4 TPY.

Dehydration Units

New Facilities

Upon FDOP, all VOC and HAP emissions from dehydration unit process vents shall be controlled by at least 98%. No control removal will be allowed.

Modified Facilities

Upon modification, all VOC and HAP emissions from new and existing dehydration unit process vents shall be controlled by at least 98%. No control removal will be allowed.



Presumptive BACT Requirements for JPAD/NPL Facilities (cont.)

Pneumatic Pumps

New Facilities

Upon FDOP, VOC and HAP emissions associated with the discharge streams of all natural gas-operated pneumatic pumps shall be controlled by at least 98% or the pump discharge streams shall be routed into a closed loop system (e.g., sales line, collection line, fuel supply line).

Modified Facilities

Upon modification, VOC and HAP emissions associated with the discharge streams of all new and existing natural gas-operated pneumatic pumps shall be controlled by at least 98% or the pump discharge streams shall be routed into a closed loop system.

New and Modified Facilities

For pneumatic pump emissions controlled by a combustion unit used to control flash emissions which may be removed, the control method for pump emissions will be evaluated upon request for approval to remove the combustion unit. (See Flashing, Page 20)

Pneumatic Controllers

New Facilities

Upon FDOP, natural gas-operated pneumatic controllers shall be low, intermittent, or zero bleed controllers or the controller discharge streams shall be routed into a closed loop system.

Modified Facilities

Upon modification, new natural gas-operated pneumatic controllers shall be low, intermittent, or zero bleed controllers or the controller discharge streams shall be routed into a closed loop system.

Within 60 days of modification, existing natural gas-operated pneumatic controllers shall be replaced by or converted to low, intermittent, or zero bleed controllers or the controller discharge streams shall be routed into a closed loop system.



Presumptive BACT Requirements for JPAD/NPL Facilities (cont.)

Produced Water Tanks

New Facilities

Upon FDOP, VOC and HAP emissions from all active produced water tanks shall be controlled by at least 98%.

Modified Facilities

Upon modification, VOC and HAP emissions from all new active produced water tanks shall be controlled by at least 98%.

Within 60 days of modification, existing open-top, active, produced water tanks shall be taken out of service for use as active produced water tanks. All active produced water tanks shall be closed top and shall have VOC and HAP emissions controlled by at least 98%.

New and Modified Facilities

Open-top or blow down tanks shall not be used as active produced water tanks but may be used for blow down or for temporary storage during emergency or upset conditions, such as spare tanks at facilities connected to liquids gathering systems, and do not have to be tied into 98% control systems.

Removal of water tank emissions control may be allowed upon approval. (See Flashing, Page 20)

Fugitive Emissions

New Facilities

Upon FDOP, for fugitive VOC emissions from a production site that are less than 4 TPY, operators shall follow the semi-annual monitoring frequency in 40 CFR part 60, Subpart OOOOa (as published in the federal register on June 3, 2016 [Federal Register Vol. 81 pg. 35824-35941]).

Modified Facilities

Upon modification, for fugitive VOC emissions from a production site that are less than 4 TPY, operators shall follow the semi-annual monitoring frequency in 40 CFR part 60, Subpart OOOOa (as published in the federal register on June 3, 2016 [Federal Register Vol. 81 pg. 35824-35941]).

For new and modified facilities where fugitive emissions are greater than or equal to 4 TPY of VOCs, operators shall submit a FEM Protocol. The fugitive emission monitoring in the FEM Protocol shall be no less frequent than quarterly, and may consist of Method 21, infrared camera, AVO inspections, or some combination thereof and must be approved by the Division. A proposed FEM Protocol consisting of only AVO inspections will not be accepted by the Division.



Presumptive BACT Requirements for JPAD/NPL Facilities (cont.)

Truck Loading

New Facilities

Within 60 days of FDOP, loading emissions containing greater than or equal to 6 TPY VOC and HAP emissions shall be controlled. Operators are expected to utilize a vapor collection system or equivalent device for the truck loading operation that is assumed, based on AP-42 Section 5.2, to capture a minimum of 70% of the truck loading vapors. The captured vapors are to be routed to a smokeless combustion device with a reported destruction efficiency of 98%, or routed to an equivalent control.

Modified Facilities

Upon modification, all new and existing VOC and HAP loading emissions containing greater than or equal to 6 TPY VOC and HAP emissions shall be controlled. Operators are expected to utilize a vapor collection system or equivalent device for the truck loading operation that is assumed, based on AP-42 Section 5.2, to capture a minimum of 70% of the truck loading vapors. The captured vapors are to be routed to a smokeless combustion device with a reported destruction efficiency of 98%, or routed to an equivalent control.

New and Modified Facilities

The removal of a control device(s) may be allowed upon approval if after at least one year from the date of installation VOC and HAP loading emissions have declined to less than, and are expected to remain below 4 TPY of VOC and HAPs.

Note: Safety issues associated with the control of truck loading emissions will be taken into consideration by the Division. Applicants will be required to demonstrate that safety issues would preclude the application of controls, and the demonstration will have to be approved by the Division prior to the date that controls would be required under the Guidance.

Well Completions

Operators shall submit applications to perform well completions using Best Management Practices. One permit will be issued to each company that drills and completes wells within the **JPAD/NPL**. The permits will be modeled after those issued to operators completing wells in the Jonah and Pinedale Anticline Development Area. An example of a well completions or “Green Completions” permit is available on the AQD website, <http://deq.wyoming.gov/aqd/new-source-review> or a copy may be obtained by contacting the Wyoming Air Quality Division at (307) 777-7391.



Presumptive BACT Requirements for JPAD/NPL Facilities (cont.)

Blowdown/Venting

Best Management Practices (BMP) and information gathering requirements will be incorporated into permits for new and modified facilities.

BMP: During manual and automated blow down/venting episodes associated with liquids unloading, wellbore depressurization in preparation for maintenance or repair, hydrate clearing, emergency operations, equipment depressurization, etc., associated VOC and HAP emissions shall be minimized to the extent practicable. During manual blow down or venting, personnel shall remain on site to ensure minimal gas venting occurs.

Information Gathering: Specific recordkeeping and reporting requirements will be established during the permitting process and will include estimates of associated regulated air pollutants, reasons for episodes, durations of episodes, steps taken to minimize emissions and descriptions of emission estimation methods.

Emission Sources without Presumptive BACT requirements

For uncontrolled sources emitting greater than or equal to 4 TPY VOC and HAPs that do not have P-BACT requirements, a BACT analysis shall be filed with the permit application for the associated facility.



Determining P-BACT Flashing and S/W/B Emissions

Flashing losses occur when produced liquids (crude oil or condensate) are exposed to temperature increases or pressure drops as they are transferred from production vessels to other vessels or to atmospheric storage tanks. For purposes of this guidance, the term “**flash emissions**” refers to VOC and HAP pollutants associated with entrained natural gas vapors released to the atmosphere from hydrocarbon liquids in surface production equipment. This production equipment may include gun barrels, separators, treaters, produced water tanks, gas drips, freewater knockouts, etc. In addition to flash emissions, vessels containing hydrocarbon liquids also have emissions associated with **working** and **breathing** (also called standing) losses. These are vapors displaced from oil or condensate due to evaporation and agitating.

Use the following steps to determine projected potential flashing and working/breathing losses:

STEP 1: 30 days after the First Date of Production calculate the **average daily condensate or oil production**.

*Example: Well produced 600 BBL during the first 30 days after the First Date of Production.
average daily condensate/oil production = $600 \text{ BBL} \div 30 \text{ days} = 20 \text{ BPD}$*

STEP 2: Calculate the **projected first year annualized average daily condensate/oil production rate** by multiplying the average 30-day rate times 0.6. This effectively results in a first year, annualized daily production rate, which is 20% of the initial production rate. Additionally, this effectively accounts for an 80% decline in daily production by the end of the first year. (described in more detail on page 36)

Example:

***projected first year, annualized average daily oil/condensate production** = $20 \times 0.6 = 12 \text{ BPD}$*

If the expected decline rate is less than 80%, then the expected decline rate should be used. Using an expected decline rate > 80% requires pre-approval from the Division.

STEP 3: Use an approved flash emissions model or direct measurement of tank emissions to determine **projected first year VOC and HAP emissions associated with the projected first year average daily production rate**.

Actual flash and S/W/B emissions are determined the same as projected potential emissions except that the actual average daily condensate or oil production rate is used rather than a projected production rate.



Determining P-BACT Flashing and S/W/B Emissions (cont.)

Several methods are available to calculate or measure flash emissions with some being more accurate than others. Even though working/breathing/flashing losses are almost always mixed together and exit from a common vent at the same time, some methods only calculate working and breathing losses and some only calculate flashing losses. Some methods will calculate all three types of emissions simultaneously. Each method has specific constraints. For whichever method used, all supporting data used to calculate the emissions, including identification of the calculation method, description of sampling methods and copies of lab sampling analyses shall be provided with the emissions estimate.

	Method	Emissions Calculated	Comments
1	Direct measurement	working, breathing, flash	Sampling and lab analysis required. Results are relatively accurate.
2	Process Simulator	flash, working, breathing	i.e. PROMAX, HYSIM, HYSIS Software is expensive but results are accurate when based on site-specific sampling and lab analysis.
3	API E&P TANKS Software V 2.0 and higher	working, breathing, flash	Requires site specific sampling. Not as accurate as more expensive process simulators and no longer supported by the software producer (American Petroleum Institute).
4	Laboratory measurement of the Gas-Oil-Ratio (GOR) from a pressurized liquid sample	flash only	This is a direct laboratory analysis of the flash vapors emitted from a pressurized oil/condensate sample.
5	EPA TANKS 4.0.9d	working, breathing only	Program distributed by the EPA through their website at https://www3.epa.gov/ttn/chief/software/tanks/index.html

Extended hydrocarbon liquids analyses used for model input shall be no older than **three** years. Composite analyses may be used as input. These are averaged extended hydrocarbon compositions based on samples from at least five wells located in the same geographical area, producing from the same formation and under similar conditions ($\pm 25^\circ$ psig) as the well being permitted. Analyses used as the basis for the average shall be no older than **three** years.



Determining P-BACT Dehydration Unit Emissions

Dehydration units use glycol (TEG, DEG or EG) to absorb water from produced gas before it is introduced into gas sales or collection lines. Upon contact with wet gas, “lean” glycol absorbs water and other liquids. It is then considered “rich”. To remove impurities, or regenerate, the rich glycol is routed through a glycol flash separator and/or a reboiler. During flash separation and reboiling, water and hydrocarbon vapors containing VOC and HAP pollutants are released from the rich glycol. These are then discharged to the atmosphere from the dehydration unit process vents.

Use the following steps to determine projected potential dehydration unit emissions:

STEP 1: Once a new well has produced for 30 days after the First Date of Production, determine the average daily gas production rate.

Example:

*Well produced 100 MMCF during the first 30 days after the First Date of Production
average daily gas production = 100 MMCF ÷ 30 days = 3.3 MMCFD*

STEP 2: Calculate the **projected first year, annualized average daily gas production** rate by multiplying the initial average 30-day rate times 0.6. This effectively results in a first year, annualized daily production rate, which is 20% of the initial production rate. Additionally, this effectively calculates an 80% decline in daily production by the end of the first year. (described in more detail on page 36.)

Example:

***projected first year, annualized average daily gas production** = 3.3 × 0.6 = 2.0 MMCFD*

STEP 3: Use GRI-GLYCalc V4.0 or higher or other method approved by the Division with the projected first year, annualized average daily production rate to determine **potential, annualized uncontrolled VOC and HAP emissions** from the dehydration unit **process vents**. **Process vents** include reboiler still vents, glycol flash separators and still vent condensers.

Model input:

- 1) An extended hydrocarbon analysis (as defined in Chapter 8, Section 6) of wet gas sampled upstream of the reboiler contact tower. Or, a composite extended hydrocarbon analysis may be used. A composite analysis is the average composition from at least five nearby wells producing from the same formation as the new well and under the same or very similar separator pressure and temperature conditions. Samples shall be no older than three years.
- 2) The projected first year average daily gas production rate (MMCFD).
- 3) Average, actual equipment operational parameters, including wet gas temperature and pressure, dry gas water content, glycol flash separator temperature and pressure, stripping gas source and rate and average operating parameters of emission control equipment.
- 4) The **maximum lean glycol circulation rate** (gpm) for the glycol circulation pump in use. Maximum circulation rates for the most commonly used Kimray Model pumps are listed in **TABLE 1**.



Determining P-BACT Dehydration Unit Emissions (cont.)

TABLE 1

KIMRAY GLYCOL PUMP RATES				
Model #	Capacity (gpm)		Working Pressure (psi)	
	min	max	min	max
3154 PV	0.05	0.22	100	1500
1715 PV	0.13	0.67	300	1500
4015 PV	0.2	0.67	300	1500
9015 PV	0.45	1.5	300	1500
21015 PV	1.1	3.5	400	1500
45015 PV	2.77	7.5	400	1500
4015 LP	0.13	0.33	100	500
2015 SC	0.13	0.33	100	500
5015 SC	0.2	0.83	100	500
10015 SC	0.37	1.67	100	500
20015 SC	1	3.33	100	500

Data from Kimray O&G Equipment and Controls Catalog

Actual dehydration unit emissions are determined the same as projected potential emissions except that the actual average daily gas production rate is used in the GLYCalc model rather than a projected production rate.



BACT for Flashing Emissions

The following control systems or devices are accepted by the Division as meeting BACT for flash emissions:

- 1) A vapor recovery device that is designed and operated and may be demonstrated to reduce the mass content of VOC and total HAP emissions in the vapors vented to the device by at least 98%.
- 2) An enclosed, smokeless combustion device or flare that is designed and operated and may be demonstrated to reduce the mass content of VOC and total HAP emissions in the vapors vented to the device by at least 98%.
- 3) Any other control device or configuration that can be demonstrated to reduce the mass content of total HAP and VOC in the process gases vented to the device or configuration by at least 98%.
- 4) Monitoring and recordkeeping, which will demonstrate continuous and effective emission control, are required upon start up of the control system. For a combustion device this may be a thermocouple and continuous recording device or any other equivalent device to detect and record the presence of the pilot flame, or a combustion chamber temperature recorder/monitor. The monitoring/recording requirements become enforceable permit conditions.
- 5) Emissions control equipment, systems or devices, all vent lines, connections, fitting, valves, relief valves, thief hatches or any other appurtenance employed to contain and collect vapors and transport them to the emission control system or device, shall be maintained and operated during any time a well is producing such that the emissions are controlled at all times.

CAUTION: Total emissions from any facility or source shall not exceed major source levels prior to emission control installation. Major source levels are 10 TPY of any single HAP, 25 TPY of any combination of HAP or 100 TPY of any regulated pollutant. Flash emissions prior to control installation will be determined using approved emission models or methods based on actual reported production and operating conditions. Reported production includes that sold during well completion activities, which are reported to the WOGCC. Flash emissions are directly proportional to production rates, provided operational parameters remain consistent, so it is acceptable to prorate emissions based on production.



BACT for Dehydration Unit Emissions

Other emission control systems or devices than those previously discussed may be used upon approval by the Division to meet BACT requirements for emissions from dehydration unit process vents (reboiler still vents and vents from glycol flash separators or glycol flash tanks). In order to be approved, the operator must provide a demonstration certifying the system or device will reduce the mass content of total HAP and VOC in the process gases vented to the device or configuration by at least 98%.

Emissions control equipment, systems or devices, all vent lines, connections, fitting, valves, relief valves, hatches or any other appurtenance employed to contain and collect vapors and transport them to the emission control system or device, shall be maintained and operated during any time a well is producing such that the emissions are controlled at all times.

Monitoring and recordkeeping, which will demonstrate continuous and effective emission control are required upon start up of the control system. For combustion devices this may be a thermocouple and continuous recording device for the pilot flame or any other equivalent device to detect and record the presence of the pilot flame. A temperature recorder/monitor might be used to demonstrate sufficient heat of combustion or a continuous, wind-up chart recorder might be used to demonstrate continual operation by measuring and recording temperature or pressure parameters.

REMINDER: Dehydration units at oil and gas production facilities may be subject to additional NESHAP requirements under 40 CFR part 63, subpart HH. It is the operator's responsibility to comply with all applicable requirements of the NESHAP regulations.

CAUTION: Total emissions from any facility or source shall not exceed major source levels prior to emission control installation. Major source levels are 10 TPY of any single HAP, 25 TPY of any combination of HAP or 100 TPY of any regulated pollutant. Dehydration unit emissions occurring prior to the installation of required controls will be determined using the GRI-GLYCalc model or other method approved by the Division based on the maximum lean glycol circulation rate and the actual reported gas production rate including any gas, which was routed through the dehydration unit during well completion operations.



BACT for Sources without P-BACT Requirements

For emission sources without PRESUMPTIVE BACT requirements, BACT shall be addressed when the uncontrolled source emits greater than or equal to 6 TPY VOC and HAPs for sources located in the **SWA** or 4 TPY VOC and HAPs for sources located in the **UGRB** or **JPAD/NPL**.

For these sources **EITHER** the emission source will be controlled using previously implemented BACT **OR** a BACT cost analysis will be performed and submitted with the application showing either:

control is not technically feasible (i.e., due to physical constraints the emissions cannot be controlled)

OR

control is not economically reasonable (i.e., based on a control cost analysis the “cost to control per ton of pollutant reduced” is uneconomical).

CAUTION: **BACT** may be required at lower levels and for other emissions and emission sources than those stated in this guidance, but as a minimum, **BACT** shall be considered when equal to or above these guidance emission levels. For example, operators installing pumping unit engines according to Guidance might be asked to submit a BACT analysis for the engine.

Multiple pieces of the same type of equipment are considered one emission source for permitting purposes.

For example, there are five oily rag burners at a facility located in the **SWA**. Uncontrolled emissions from the five burners shall be aggregated for permitting purposes. If total uncontrolled VOC emissions from the five burners are less than the development area specific threshold of 6 TPY, BACT requirements are met with no control. If total uncontrolled emissions from the five burners are greater than or equal to 6 TPY VOC and HAPs, emissions from all five burners shall be reduced to less than 6 TPY VOC and HAPs in order to meet BACT requirements or the applicant shall demonstrate controlling the emissions is not economically reasonable nor technically feasible.



Permit Applications

For **JPAD/NPL**, **UGRB** and **SWA** facilities, unless a permit is issued prior to start up, a C6 S2 Oil & Gas Production Facilities permit application shall be filed within 90 days after the First Date of Production for a new facility or Date of Modification of an existing facility. The application notifies the AQD that the new or modified facility has begun operation. It describes the facility process, equipment and associated emissions/emissions controls and serves as a form of certification by the owner that the Presumptive BACT requirements have been met.

Whether the application is being filed after construction under the Presumptive BACT process or prior to construction, the appropriate application forms, depending upon the facility equipment and operating scenario, need to be filled out. A complete application includes the following

- A cover letter stating the purpose of the application
- Equipment list for the facility
- A written process description and process diagram for the facility, including each air emission source and the operational parameters of each source (examples provided on pages 34 & 35)
- The appropriate IMPACT forms
 - Cover Sheet
 - Emission Unit Form for all new or modified equipment
 - Pollutant Emissions Form for each emission unit
 - Release Point Form for each emission unit
 - Control Equipment Form (where applicable)
- The appropriate additional documentation (examples include)
 - Emission Summary
 - BACT cost analysis
- Explanations or demonstrations of all methods used to calculate or estimate emissions for each emission source, including controlled and uncontrolled sources. Emission calculation methods are described later.
- All applicable and required attachments, including:
 - Input and output for emission models/software/process simulations
 - Equipment manufacturer's emissions information
 - Laboratory analyses used for emission models/software/process simulations or calculations including a description of sampling procedures and handling, sampling locations, sampling location parameters (i.e., pressure and temperature at sampling port)
- Any additional attachments or information necessary for complete review of the application



Permit Applications (cont.)

As of September 2, 2014, the New Source Review program is processing all air quality permit applications electronically through the IMPACT System. There are two acceptable methods to submit an application. Please choose just one of the methods below:

- Applications may be submitted through the IMPACT portal (<https://airimpact.wyo.gov>). Submittals through the IMPACT portal are sufficient and paper copies are not required.
- One (1) paper copy (with an original signature) of each complete permit application.

The preferred method for filing the application is through the IMPACT portal.

For facilities constructed or modified under the **Presumptive BACT** process, a complete C6 S2 application shall be submitted within **90 days** of the **First Date of Production**. In the event that the IMPACT portal is not functioning properly and prevents the submittal of the application within 90 days of First Date of Production, the applicant will need to contact the Division prior to the due date of the application to inform NSR of the issue and the applicant will need to provide documentation in the permit application showing the reason for the delayed submittal. Examples of acceptable documentation include a screen shot showing the issue or a copy of email correspondence between the applicant and the Division discussing the problem.

If not submitting through the IMPACT portal, download IMPACT application forms from the AQD website:

<http://deq.wyoming.gov/aqd/new-source-review/resources/application-forms/>

The oil and gas applications forms are contained in one Microsoft Excel file. The file name for the IMPACT application forms is “01 - AQD - NSR - Application Form”.

If you need assistance with the applications forms, contact the Wyoming Air Quality Division at **(307) 777-7391**.

Address written requests to: Wyoming Department of Environmental Quality
Air Quality Division
(see WDEQ website for current mailing address)
attn: O&G NSR Permitting*

*To assist with the proper routing of the application and application materials, please make sure to address the materials to O&G NSR Permitting.

With the implementation of an electronic permitting system, the NOI process will no longer be utilized for new applications. Minor equipment installations and/or modifications that qualified for a NOI will now submit a complete application with the appropriate information listed on page 32. IMPACT forms and associated information are required for new or modified equipment.



Permit Applications (cont.)

Example Process Diagram & Description

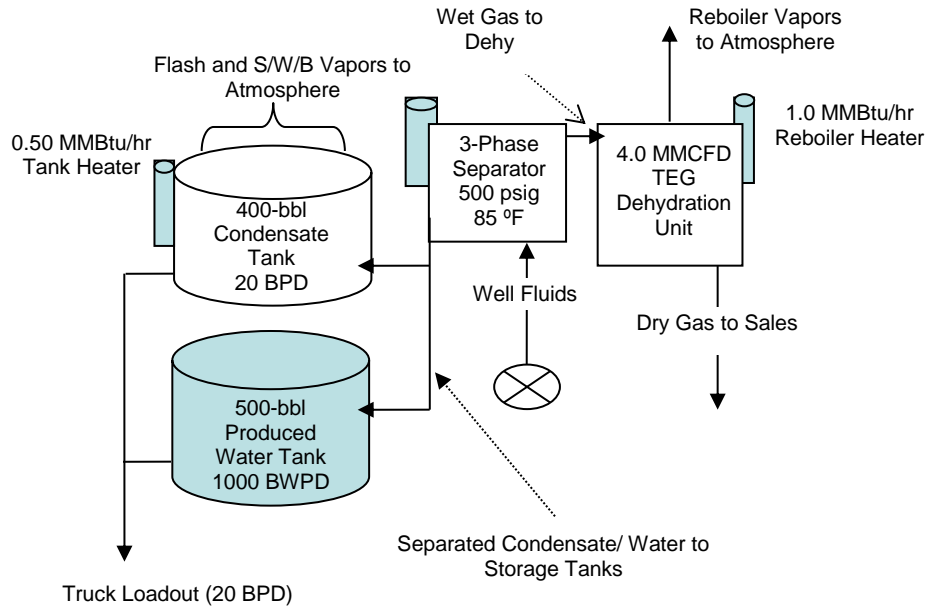

EXAMPLE: Air emission sources in the diagram are the condensate storage tank from which vapors are vented to the atmosphere, the dehydration unit reboiler still vent and the three natural gas-fired process heaters. Produced fluids are directed to the 3-phase separator for separation of condensate/water/gas. Wet gas is directed to the TEG dehydration unit for drying. Separated condensate and water are routed to the appropriate tanks for storage prior to being hauled from location via truck. Produced gas is used as burner fuel. Reboiler vapors and flash emissions are vented to the atmosphere along with S/W/B losses from the condensate tank.



Permit Applications (cont.)

Example Process Diagram & Description

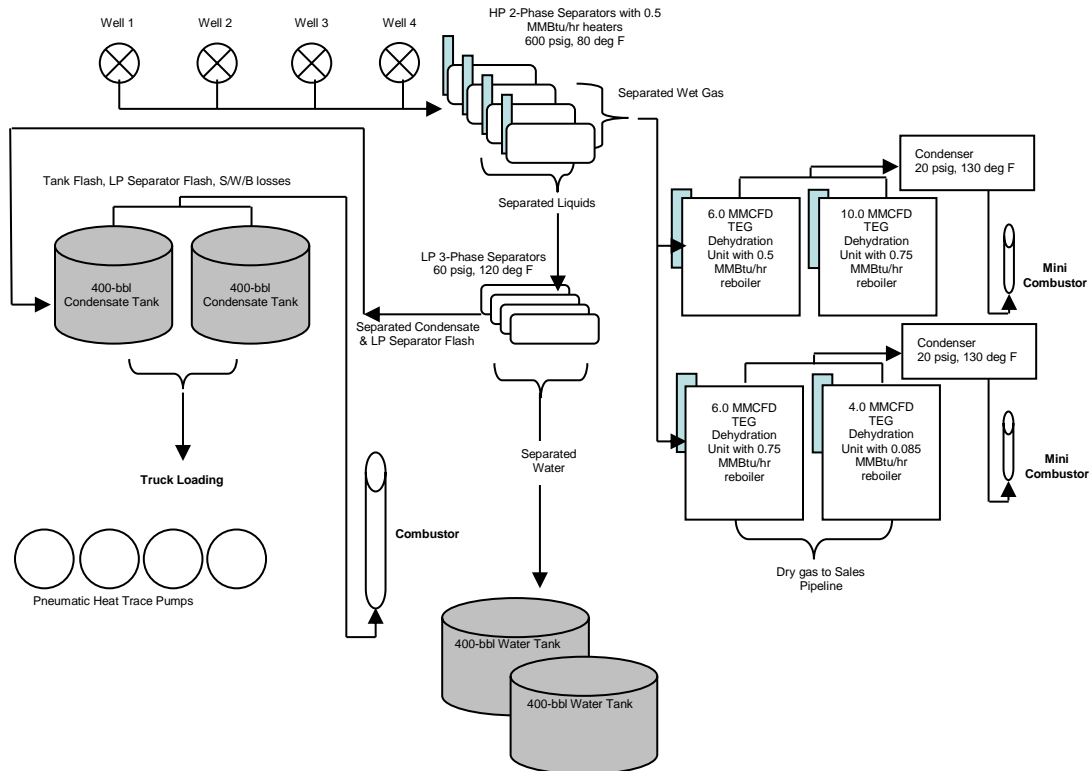

EXAMPLE: Total well fluids from four wells flow to the 2-ph HP separators. Wet gas from the HP separators flows to the four dehydration units. Separated fluids from the 2-ph HP separators flows to the 3-ph LP separators. Separated condensate and water flows from the 3-ph LP separators to the storage tanks. Gas released in the 3-ph separators is routed to the condensate storage tanks. Tank vapors, including tank flash, gas from the 3-ph LP separators and S/W/B vapors are collected and directed to a 30-foot smokeless combustor. The temperature of the combustor is continually monitored and recorded using a SCADA (supervisory control and data acquisition) system. Reboiler still vents vapors flow through condensers. Condensed liquids are pumped to the condensate storage tanks. Non-condensable vapors flow to the 20-foot Mini-Combustors. The temperature of the Mini-combustors is continually monitored and recorded using a SCADA system. Pneumatic heat trace pumps operate 6 months per year using produced gas from the HP separators to operate. Vent lines from the pumps are routed into the condensate dump lines from the LP separators.

The process diagram does not need to be computer generated. A simple hand sketch is sufficient as long as the required information is included. The diagram does not need to be drawn to scale and does not need to represent the exact position of production equipment at the facility as long as the process description and operating scenario are clearly defined.



Permit Applications (cont.)

Upon receipt of a paper application, the Division must input the required application information into an electronic system (IMPACT) for processing. Once the paper application is processed, the Division sends the applicant a receipt letter. For electronic applications received via IMPACT, the Division simply issues a receipt letter after the application is received and a reviewer is assigned. The reviewer has up to 30 days to perform a completeness review to ensure adequate and correct information has been filed. If the application is deemed incomplete the reviewer will notify the applicant and request further information. Upon completeness the reviewer has 60 days to complete a technical review, write an application analysis and make any recommendations. During this process the decision to issue a permit or waiver/authorization letter takes place. If the decision is to issue a permit, the proposed permit, including compliance requirements, is published for a mandatory 30 day public comment period. If no comments are received the permit is issued once the public comment period ends. If comments are received these are addressed by the AQD. It is possible comments will warrant a public hearing. When this is the case, a final permit may be denied or delayed.

A minimum fee (\$464, subject to change) will be charged to each application. An hourly fee (\$58 per hour, subject to change) will be assessed for the time it takes AQD personnel to process the application. A bill will be sent to the applicant when the process is complete. Billing is handled as follows:

Initial billing (permits only) is assessed when a proposed permit is sent to public notice. The initial billing must be paid before AQD can issue a final permit.

Final billing is assessed for waivers/authorization letters and permits after these are issued.

NOTE: The Presumptive BACT permitting process may not be used for sour gas (H₂S) production facilities unless the only emissions of H₂S will be those associated with fugitive losses from valves, fittings, surface piping and pneumatic devices, etc. If there will be H₂S emissions associated with vented gas or tank vapors or if sour gas will be flared the applicant shall contact the Division for permitting guidance prior to construction.

No internal combustion compressor engines or generator engines may be installed under the Presumptive BACT process.

No pumping unit engines greater than 50 Hp may be installed under the Presumptive BACT permitting process. Such engines shall be permitted prior to installation.



The 0.6 decline factor

The first year daily production rates are represented by the jagged line **BOX 1**. The area under the line represents the total actual production volume for the first year. It is difficult to calculate the total volume under the jagged line so it is smoothed out **BOX 2** using statistical methods.

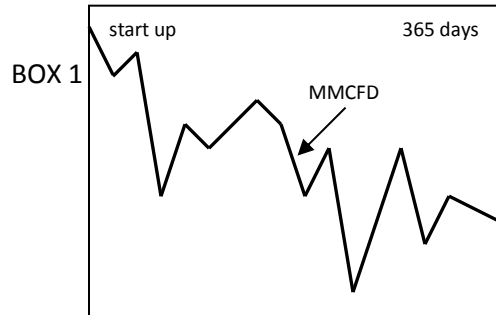

EXAMPLE - actual daily gas production rate vs time

Actual production during the first year is represented by the area under the jagged line which ultimately turns out to be ≈ 730 MMCF.

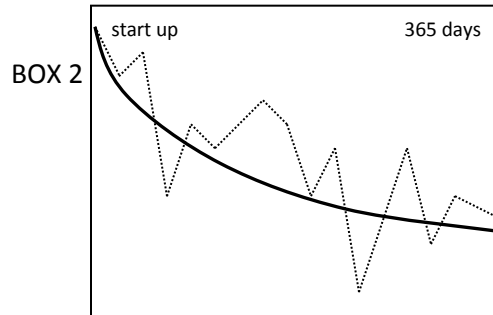

The jagged line representing daily production is “smoothed” out using statistical methods.

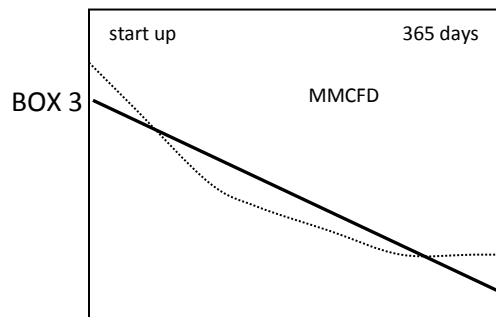

The “smoothed” curve in BOX 2 is “straightened” out using mathematical methods.

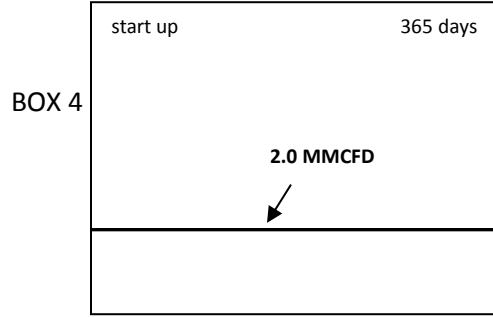

“leveled” out, projected daily gas production rate vs time

Total projected production for the first year is represented by the area under the straight line
 $2 \text{ MMCFD} \times 365 \text{ days} = 730 \text{ MMCF}$

First year projected emissions are based on 730 MMCF of produced gas.

The smoothed curve is “straightened” out in **BOX 3**, then “leveled” out in **BOX 4**. Now the total production for the first year is represented by the area under the line in **BOX 4**, which is easily calculated. Production curves from a large sampling of Wyoming wells indicate the average well declines by 80% during the first year. That 80% decline is represented by the level line in **BOX 4** after the first 30-day average production rate is multiplied by 0.6. For the first month the well makes an average 3.333 MMCFD. With 80% decline during the first year, the well will make 0.667 MMCFD at the end of the first year ($3.333 - 0.8(3.333) = 0.667$). Then the average daily production rate over 365 days is $(3.333 + 0.667)/2 = 2.0$ MMCFD, which is the same as $3.333 \times 0.6 = 2.0$.



Pumping Unit Engines

A pumping unit engine is an engine used to provide electrical or mechanical energy to a pump in order to produce a well.

This Guidance does not apply to compressor engines, generator engines, engines used for vapor recovery, or pumping unit engines greater than 50 Hp.

This Guidance replaces the March 9, 2012 Pumping Unit Engine Emissions Policy.

Historically, AQD has allowed the installation of pumping unit engines at oil & gas production facilities as part of the Guidance. Engines were allowed to be installed prior to permit issuance, provided the engine was site rated for less than 50 Hp and emitted less than 5 TPY of NO_x.

The Guidance does not however preclude the Division from asking the applicant to submit a Best Available Control Technology (BACT) analysis to determine if emissions from the engine are technically feasible and economically reasonable to control. As demonstrated in the March 9, 2012 Pumping Unit Engine Emissions Policy, BACT is a moving target and relying on an emissions threshold of 5 TPY NO_x was no longer considered BACT for pumping unit engines less than 50 Hp. AQD will continue to allow installation of pumping unit engines prior to obtaining a permit provided the engine meets BACT and the requirements listed below.

Installation of pumping unit engines site rated for 50 Hp or less is allowed provided the engine meets NO_x emissions of 2.0 g/hp-hr and CO emissions of 3.0 g/hp-hr.

Initial and/or periodic emissions testing and monitoring of the pumping unit engine may be established in the permit or permit waiver/authorization letter.

Permit applications for pumping unit engines shall be submitted separately from the permit applications for production equipment, and within the same timeframes required for the production equipment, namely, within 90 days after the First Date of Production for a new facility or Date of Modification of an existing facility.

APPENDIX A

EMISSION CALCULATIONS

Emissions from processes and equipment, which shall be accounted for and reported by applicants FOR ALL O&G PRODUCTION FACILITIES are:

Emission Unit or Process	Associated Emissions
storage tanks (flashing & S/W/B losses)	VOC HAP
pressurized vessels (flashing losses)	VOC HAP
dehydration units (reboiler still vents & glycol flash tanks)	VOC HAP
natural gas fired burners, heaters, flares	VOC NO _x CO
natural gas operated pneumatic controllers/pumps	VOC HAP
fugitives	VOC HAP
natural gas fired engines	VOC NO _x CO
truck load out	VOC HAP

AP-42 EMISSION FACTORS

Throughout this Guidance reference is made to AP-42 emission factors. The complete AP-42 compilation may be downloaded from <https://www3.epa.gov/ttn/chief/ap42/index.html>.

STORAGE TANK EMISSIONS

Flashing and Standing/Working/Breathing (S/W/B) losses are the terms for emissions which occur when hydrocarbon liquids are exposed to temperature and pressure changes (i.e., from separator pressure and temperature to storage tank pressure and temperature) causing hydrocarbon vapors to be released from the liquids. The vapors may contain VOCs, HAPs and H₂S.

Software is available for modeling these emissions. Models accepted by the Air Quality Division are those using Peng-Robinson or S-R-K methods based on widely accepted principals of behavior for hydrocarbon vapors and liquids. Some common software programs for estimating these emissions are PROMAX, HYSIM, HYSYS, K-FLASH, PROSIM and API E&P TANKS (v2.0 and higher). The models require input detailing chemical properties of the fluids handled and physical operating parameters of the system(s) and production equipment. Output from the models includes volumes, rates and chemical components of the individual process streams from tanks and pressurized vessels.

Emissions from storage tanks may also be physically measured. In order to do so all tank valves, hatches, relief devices, leaks, etc. shall be sealed. Tank vapors shall only be allowed to exit the tank through a metered outlet. Usually this requires a meter capable of measuring low volumes. The measurement period shall last long enough to capture a representative tank vapor volume. An extended hydrocarbon analysis of the vapors shall be obtained along with the vapor volume.

MEASURED TANK FLASH EMISSIONS – EXAMPLE CALCULATION

The tons per year of VOC and HAP emissions associated with tank flashing are calculated as follows:

Given: Condensate tank vapors = 1000 scf/day
VOC weight % = 20
HAP weight % = 5
Condensate vapor molecular weight = 20 lb/lb-mol

TPY total flash emissions = $1000 \text{ scf/day} \times (1 \text{ lb-mol}/379 \text{ scf}) \times (20 \text{ lb/lb-mol}) \times (\text{ton}/2000 \text{ lb}) \times (365 \text{ days/year}) = 9.6 \text{ TPY}$

TPY total VOC emissions = $9.6 \text{ TPY} \times (20 \text{ weight \% VOC} / 100) = 1.9 \text{ TPY VOC}$

TPY total HAP emissions = $9.6 \text{ TPY} \times (5 \text{ weight \% HAP} / 100) = 0.5 \text{ TPY HAP}$

S/W/B losses

Not all software programs include tools for estimating S/W/B losses. There is free software available from the EPA named EPA TANKS. The most recent available version of EPA TANKS may be downloaded from the EPA website at <https://www3.epa.gov/ttn/chief/software/tanks/index.html>.

PRESSURIZED VESSELS

Whenever vapors from a pressurized vessel (separator, treater, FWKO, flash separator, gunbarrel, gas boot, etc.) are released to the atmosphere, other than during times of emergency or upset conditions, emissions associated with those vapors shall be accounted for.

The same flash emission models mentioned above, for tank flash emissions, are often used to estimate emissions from pressurized vessels. Again, an extended hydrocarbon analysis of the liquids involved and actual operational conditions of the production equipment are necessary as input for the models.

Even when vapors from a pressurized vessel are collected for use as process burner fuel or fuel for an IC engine, for example, emissions associated with the total vapors shall be accounted for when considering potential emissions from a facility. If the volume and rate of vented vapors are known and an extended hydrocarbon analysis is available, associated emissions may be calculated in the same manner as described on Page 39 (calculation of flash emissions). If these are not available, the volumes shall be measured and analyzed in order to perform the calculations and determine associated emissions.

DEHYDRATION UNIT EMISSIONS

Air pollutants, mostly VOCs and HAPs, are associated vapors released from reboiler still vents and glycol flash separators. To estimate these emissions the GRI-GLYCalc v4.0 or higher model or other approved method is used. This relatively inexpensive software was created by the Gas Research Institute (GRI) for determining optimal operating parameters for dehydration units and is available from the Gas Technology Institute (GTI) with a website address of <http://sales.gastechnology.org/>.

Input for the model includes an extended hydrocarbon analysis of wet gas sampled upstream of the contact tower, actual operating parameters of all associated equipment (i.e., reboiler still vent temp., flash separator temp., dry gas flow rate, glycol recirculation rate, condenser, etc.) and physical properties of the dry and wet gas streams. The model provides an estimate of individual emission components and the rates of vapor and liquid streams exiting each process vent of a dehydration unit. When submitting a GRI-GLYCalc

model it is only necessary to submit the INPUT SUMMARY, EMISSIONS SUMMARY, CONDENSER VENT OUTPUT (if applicable) and FLASH TANK OUTPUT (if applicable).

NATURAL GAS FIRED HEATERS (external combustion equipment)

NO_x, CO and VOC emissions from process unit heaters should be calculated using the emission factors (EF) below from EPA AP-42, Tables 1.4-1, 1.4-2 and 1.5-1. The following lists these factors:

Emission Factors for Industrial and Commercial Boilers

Pollutant	Butane Gas ¹ (0.3 to 100 MMBtu/hr heat input)	Propane Gas ² (0.3 to 100 MMBtu/hr heat input)	Natural Gas ³ <100 MMBtu/hr heat input	Natural Gas ³
NO _x ⁴	15 lb/1000 gal	13 lb/1000 gal	0.098 lb/MMBtu	100 lb/MMcf
CO ⁴	8.4 lb/1000 gal	7.5 lb/1000 gal	0.082 lb/MMBtu	84 lb/MMcf
TOC ^{4,5}	1.1 lb/1000 gal	1.0 lb/1000 gal	0.010 lb/MMBtu	11 lb/MMcf

- 1 Based on an average heating value of 102 × 10⁶ Btu/1000 gallons of Butane.
- 2 Based on an average heating value of 91.5 × 10⁶ Btu/1000 gallons of Propane.
- 3 Based on an average heating value of 1020 Btu/SCF of natural gas.
- 4 The emission factors in this table may be converted to other natural gas heating values by multiplying the given emission factors by the ratio of the heating value of the actual gas used to the average heating values listed
 Converted EF = (EF from table above × (actual heat value/heat value in table)).
- 5 VOC emissions may be determined by multiplying the calculated TOC (total organic compounds) emission rate by the weight percent of VOC compounds in the actual fuel gas stream.

HEATER EMISSIONS - EXAMPLE CALCULATION

Given: Separator heater rating = 0.5 MMBtu/hr
 Gas Heating Value = 1300 Btu/scf
 VOC weight % = 20
 Annual operating hours = 8760
 NO_x EF = 100 lb/MMcf
 CO EF = 84 lb/MMcf
 TOC EF = 11 lb/MMcf

NO_x emissions = (0.5 MMBtu/hr) × (100 lb/MMcf) × (1300 Btu/1020 Btu) x (1 scf/1020 Btu) × (8760 hr/yr) × (ton/2000 lb) = 0.27 TPY NO_x

For CO emissions, the same calculation is used except the EF is 84 lb/MMcf.

VOC emissions = 0.5 × 11 x (1300/1020) x 1/1020 × 8760/2000 x (20% VOC/100) = 0.006 VOC TPY VOC ← INSIGNIFICANT at less than 0.1 TPY

FLARES

The NO_x and CO emissions for flares should be based on **0.14 lb NO_x/MMBtu and 0.035 lb CO/MMBtu** (Emission factors from Section 4 of EPA Document “Preferred and Alternative Methods for Estimating Air Emissions from Oil and Gas Field Production and Processing Operations”) and the reported fuel usage based heat input. VOC and HAP emissions from flaring should be based upon the guaranteed destruction efficiency of the flare. Reported flared gases shall include pilot gas with heat content and flared gas with average estimated heat content. The rationale for using these factors as opposed to AP-42 factors for flares is that the flare factors are believed to be only applicable to chemical plant type flares engaged in burning low BTU gases. The gases typically burned in flares in Wyoming contain more than 900 Btu/scf and emissions are expected to be closer to the AP-42 factors for NO_x and CO from gas fired heaters and boilers greater than 10 MMBtu/hr.

FLARE EMISSIONS - EXAMPLE CALCULATIONS – CONDENSATE TANK FLASH

Given: Total waste gas = 125 scf/hr
Gas heating value = 1350 Btu/scf

$$\text{NO}_x \text{ emissions} = (125 \text{ scf/hr}) \times (1350 \text{ Btu/scf}) \times (0.14 \text{ lb NO}_x/\text{MMBtu}) \times (\text{MMBtu}/10^6 \text{ Btu}) \times (8760 \text{ hr/yr}) \times (1 \text{ ton}/2000 \text{ lb}) = 0.1 \text{ TPY NO}_x$$

FLARE PILOT EMISSIONS

Given: Flare pilot gas = 5 scf/min
Gas heating value = 1000 Btu/scf

$$\text{NO}_x \text{ emissions} = (5 \text{ scf/min}) \times (1000 \text{ Btu/scf}) \times (0.14 \text{ lb NO}_x/\text{MMBtu}) \times (\text{MMBtu}/10^6 \text{ Btu}) \times (60 \text{ min/hr}) \times (8760 \text{ hr/yr}) \times (1 \text{ ton}/2000 \text{ lb}) \\ = 0.18 \text{ TPY NO}_x$$

For CO emissions the same calculations are used except the EF for CO is 0.035 lb/MMBtu.

FLARE EMISSIONS EXAMPLE CALCULATION – DEHYDRATION UNITS

Given: Glycol flash separator vapors = 25 scf/min
Reboiler still vent vapors = 5 scf/min
Total waste gas = 30 scf/min (25 scf/min glycol flash vapors + 5 scf/min reboiler still vent vapors)
Gas Heating Value = 1050 Btu/scf (**assume at least 1000 BTU/SCF if the heat content is unknown**)

$$\text{NO}_x \text{ emissions} = (30 \text{ scf/min}) \times (1050 \text{ Btu/scf}) \times (0.14 \text{ lb NO}_x/\text{MMBtu}) \times (\text{MMBtu}/10^6 \text{ Btu}) \times (60 \text{ min/hr}) \times (8760 \text{ hr/yr}) \times (1 \text{ ton}/2000 \text{ lb}) \\ = 1.1 \text{ TPY NO}_x$$

For CO emissions the same calculations are used except the EF for CO is 0.035 lb/MMBtu.

PNEUMATIC PUMPS

If a pneumatic pump uses natural gas as the motive gas, the pump will release VOC and HAP emissions each time it strokes since all motive gas is vented by the pump. To determine emissions from the pump, manufacturer’s information regarding gas usage shall be known as well as the hydrocarbon composition of the motive gas.

PNEUMATIC PUMP EMISSIONS - EXAMPLE CALCULATION

A Texsteam Series MX pump is used to circulate hot glycol in heat trace lines. The pump moves 0.15 gallons per 40 strokes and is currently stroking at 20 strokes per minute (spm). The pump requires 24 scf for each gallon of glycol pumped. The pump motive gas weighs 20 lb/lb-mol and contains 50 wt% VOCs and 30 wt% HAPs.

Pump usage/vent rate = (20 strokes/min) × (0.15 gallons/40 strokes) × (24 scf/gallon) = 1.8 scf/min

VOC emissions = (1.8 scf/min) × (20 lb/lb-mol) × (lb-mol/379 scf) × (ton/2000 lb) × (525600 min/yr) × (50 wt% VOC/100) = 12.5 TPY VOC

PNEUMATIC CONTROLLERS

Emissions from continuous bleed pneumatic controllers shall be based on the manufacturer-certified bleed rates. Emissions from intermittent vent controllers shall be based on the volume of gas required for actuation and the applicant's best engineering estimate of the frequency of actuations.

TRUCK LOADING

VOC emissions from loading oil or condensate into tank trucks should be estimated using the following formula with data from AP-42 tables.

$$L_L = 12.46 \times S \times P \times M/T$$

Where: L_L = loading loss, pound per 1,000 gallons of liquid loaded (lb/1000 gal)

S = a saturation factor (See Table 5.2-1 below)

P = true vapor pressure of liquid loaded (psia)

M = molecular weight of tank vapors (lb/lb-mol)

T = temperature of bulk liquid loaded (°R) (°R = °F + 460)

"S" values are obtained from Table 5.2-1.

"M" and "N" values are obtained from Table 7.1-2.

Table 5.2-1 Saturation (S) Factors for Calculating Petroleum Liquid Loading Losses

Cargo Carrier	Mode of Operation	"S" Factor
tank trucks and rail tank cars	submerged loading of a clean cargo tank	0.50
	submerged loading: dedicated normal service	0.60
	submerged loading: dedicated vapor balance service	1.00
	splash loading of a clean cargo tank	1.45
	splash loading: dedicated normal service	1.45
	splash loading: dedicated vapor balance service	1.00

Table 7.1-2 Properties of Selected Petroleum Liquids

Only crude oil properties are supplied here. The full table of values can be found in AP-42, Table 7.1-2)

petroleum liquid	vapor molecular weight at 60°F (lb/lb-mol)	condensed vapor density at 60°F (lb/gal)	liquid density at 60°F (lb/gal)	true vapor pressure (psi) at various temperatures in °F						
				40	50	60	70	80	90	100
	"M"			"P"						
Crude Oil RVP 5	50	4.5	7.1	1.8	2.3	2.8	3.4	4.0	4.8	5.7

TRUCK LOADOUT - EXAMPLE CALCULATION

Given: Condensate loaded = 360 bbl crude/month

S = 0.6
 P = 2.3 psi
 M = 50 lb/lb-mol
 T = 50

$$L_L = \frac{(12.46) \times (0.60) \times (2.3 \text{ psi}) \times (50 \text{ lb/lb-mol})}{(50^\circ\text{F} + 460)} = 1.69 \text{ lb/1000 gal}$$

$$\text{Loading losses (TPY)} = (1.69 \text{ lb/1000 gal}) \times (\text{annual sales of } 360 \text{ bbl/mo}) \times (12 \text{ mo/yr}) \times (42 \text{ gal/bbl}) \times (\text{ton}/2000 \text{ lb}) = 0.15 \text{ TPY}$$

Capture efficiencies are determined on a case-by-case basis for controlled sites.

FUGITIVE EMISSIONS

The easiest way to calculate total hydrocarbon fugitive emissions is to multiply the number of components at a site by the EPA Average Emissions Factors shown in the tables below. The first table lists the average emission rates of **total hydrocarbon** (THC) to be assumed for all components in hydrocarbon service installed at a site. The factors are current as of June 15, 1996 and given in pounds per component - day (lb/component-day). The second table lists speciated rates.

The only information needed for this method is a count or estimate of the number of flanges, connectors (other than flanges), open-ended lines, pumps, valves and "other" components at the site grouped by stream (gas, light oil, heavy oil, water/oil). The number of components can be determined by either counting them in the field or by estimating them.

**EPA Average Emission Factors for Total Hydrocarbon (THC) Emissions
 From O&G Production Operations**
 (lb/component-day)

equipment type	equipment service category			
	gas	heavy oil (< 20°API)	light oil (> 20°API)	water/light oil ¹
connector	.011	.0004	.011	.0058
flange	.021	.000021	.0058	.00015
open ended line	.11	.0074	.074	.013
other ²	.47	.0017	.4	.74
pump	.13	not available	.69	.0013
valve	.24	.00044	.13	.0052

SOURCE: US EPA Bulletin Board (Leaks_OG.WP5; 8/9/1995)

¹ The water/light oil emission factors apply to water streams in light oil service with water content between 50% and 99%. For streams with water content > 99% the emission rate is considered negligible.

² The “other” equipment type includes compressor, pressure relief valves, diaphragms, drains, dump arms, hatches, instruments, meters, polished rods and vents.

NOTE: The emission factors in the table above are not intended to be used to represent emissions from components that are improperly designed (e.g., enardo valves over pressurizing, failure of thief hatches to reseal after over pressurizing) or equipment not maintained properly (e.g., thief hatch left open). For example, emissions from an enardo valve on a condensate tank vent line, operating in the full or partially open position due to excessive tank vapor pressure that exceeds the pressure setting of the enardo valve, are not considered to be fugitive emissions.

Speciated hydrocarbon emission rates can be estimated by multiplying the total hydrocarbon emission rates obtained from the table above by actual measured weight fractions. If measured data is not available, contact the Division for further guidance.

FUGITIVE EMISSIONS - EXAMPLE CALCULATION

Given: 25 valves in light oil service

THC emission factor = 0.13 lb/component-day

VOC weight fraction = 0.292

HAP weight fractions = 0.02430 + 0.00027 + 0.00075 + 0.00017 + 0.00036 = 0.0259

VOC emissions = 25 valves × 0.13 lb THC/valves-day × 1 ton/2000 lb × 365 day/hr × 0.292 = 0.17 TPY VOC

HAP emissions = 25 valves × 0.13 lb THC/valves-day × 1 ton/2000 lb × 365 day/yr × 0.0259 = 0.015 TPY total HAPs

INTERNAL COMBUSTION PUMPING UNIT ENGINE EMISSIONS

The method for calculating engine emissions is to use emission factors provided by the engine manufacturer, the maximum site-rated horsepower and the annual operating hours.

PUMPING UNIT ENGINE EMISSIONS - EXAMPLE CALCULATION

Given: Manufacturer's NO_x emission factor = 2 g/hp-hr
Maximum site-rated horsepower = 250 hp
Annual operating hours = 8760

NO_x emissions = (2.0 g/hp-hr) × (250 hp) × (8760 hr/yr) × (ton/2000 lb) × (1 lb/453.6 g) = 4.8 TPY

For CO and VOC emissions the same calculations are used except the manufacturer's EF for CO and VOC are used.

CONVERTING MOLE PERCENT TO WEIGHT PERCENT

Many emission estimation and calculation methods require weight percent to be used, rather than mole percent. Most lab analyses list gas constituents in mole percent, however you can request the lab provide both mole and weight percent.

You may download the Excel spreadsheet to convert mole percent to weight percent, at <http://deq.wyoming.gov/aqd/new-source-review/>.

APPENDIX B

DEFINITIONS

Average Daily Production – The qualified maximum total production of domestic crude petroleum and petroleum condensates including natural gas liquids produced from a well during a certain period of time (i.e. 1-month, 1-year) divided by the number of calendar days in the certain period during which the well produced. For example, the average 30-daily condensate production rate for well ABC is the qualified maximum total condensate production during the 30-day period $x(\text{BBL}) \div 30(\text{days}) = y(\text{BPD})$. If well ABC only produced 5 days out of the 30-day period, then the average daily condensate production rate for the well is $x(\text{BBL}) \div 5(\text{days}) = y(\text{BPD})$.

Closed System – A vessel (treater, separator), pipeline, sales line, gathering line, collection line, field gas supply or distribution line or any other vessel or line from which no vapors or liquids can exit through open lines, holes, vents or valves unless those lines, holes, vents or valves are connected to another closed system or to a source of continual and complete combustion, unless the vent or valve is a relief device that is designed and intended to open only during emergency situations.

Completion – An oil well shall be considered completed when the first new oil is produced through wellhead equipment into lease tanks from the producing interval after the production string has been run. A gas well shall be considered completed when the well is capable of producing gas through wellhead equipment from the producing zone after the production string has been run.

Condensate – Hydrocarbon liquid separated from natural gas that condenses (becomes liquid) due to changes in temperature, pressure, or both, and remains liquid at standard conditions.

Custody Transfer – The transfer of produced petroleum and/or condensate, after processing and/or treatment in the producing operations, from storage vessels or automatic transfer facilities to pipelines or any other forms of transportation.

Division – The Wyoming Department of Environmental Quality, Air Quality Division.

First Date of Production – The date permanent production equipment is in place and product is consistently flowing to sales lines, gathering lines or storage tanks. Production occurring during well completion activities which is routed to temporary production equipment is considered to occur prior to the First Date of Production. If extended periods of time pass between zone completions but production from initially completed zones is consistently flowing to permanent production equipment, the First Date of Production is the date when production from the initial zones began consistently flowing to the permanent production equipment, even though more zones will be completed later

Flashing Emissions – means VOC emissions, including HAP components, which occur when gases are released from produced liquids (oil, condensate, produced water, or a mixture thereof) that are exposed to temperature increases or pressure drops as they are transferred from pressurized vessels to lower pressure separation vessels or to atmospheric storage tanks.

Fugitive Emissions (Fugitives) – Those emissions which could not reasonably pass through a stack, chimney, vent, or other functionally equivalent opening. At oil and gas production facilities, these air emissions result from gas vapors escaping through and around seals, packing, gaskets, threads, and other such pressure sealing connections.

Gas – All natural gases and all hydrocarbons not defined as oil.

Gas Well – A well, the principal production of which, at the mouth of the well, is gas, as defined by the Wyoming Conservation Law.

HAP – Pollutants identified in Section 112(b) of the Clean Air Act. Typical hazardous air pollutants include benzene, toluene, ethyl-benzene, xylene, n-hexane, formaldehyde, methanol and others.

Low bleed pneumatic controller – A continuous bleed device that emits less than 6 scf/hr. The Division considers controllers that are operated in accordance with manufacturer design specifications and have a manufacturer-designed emission rate that satisfies the 6 scf/hr threshold, to meet the definition of low bleed pneumatic controller.

Intermittent pneumatic controller – An intermittent vent pneumatic controller is a controller that is designed to vent non-continuously.

Major Stationary Source– A facility which either has the potential to emit 250 TPY or more of any one regulated air pollutant or is a named facility and has the potential to emit 100 TPY or more of any one regulated air pollutant. For a facility located in a non-attainment area, the definition of major emitting facility is subject to change based on the area's classification. See WAQSR Chapter 6, Section 13.

Major Source – Any stationary source which emits or has the potential to emit either 100 TPY or more of a regulated air pollutant, 10 TPY or more of any hazardous air pollutant, or 25 TPY or more of any combination of hazardous air pollutants.

Modified Facility – An existing facility becomes modified once production streams or production equipment associated with another well or wells is added to or tied into it. The date modification occurs to an existing facility is the First Date of Production for the added well or the date the production streams associated with an additional well or wells are tied into equipment at the existing facility.

Examples of facility modifications not involving new wells or added production from other wells that would require the installation of presumptive BACT controls on **condensate tanks and dehydration units** are:

- Increasing the production rate by fracturing, recompletion of a current production zone or additional production zones, or the introduction of artificial lift methods such that the uncontrolled, total tank emissions (flashing + S/W/B) are greater than or equal to 10 tons per year (TPY) VOC and HAPs or uncontrolled dehydration unit emissions are greater than or equal to 6 TPY VOC and HAPs.

An example of a modification not involving new wells or added production from other wells that would require the installation of limited presumptive BACT controls (limited to the new equipment only) is:

- Existing production equipment is replaced with larger equipment, such that the uncontrolled, total tank emissions (flashing + S/W/B) are greater than or equal to 10 tons per year (TPY) VOC and HAPs or uncontrolled dehydration unit emissions are greater than or equal to 6 TPY VOC and HAPs.

Note 1: When equipment with Presumptive BACT requirements is added to a facility but doesn't trigger the definition of a modified facility, the Presumptive BACT requirements only have to be met for the new equipment (i.e., a pneumatic methanol pump is added, this new pump would have to either be controlled or solar, air or electric).

Note 2: For existing facilities with controls already in place*, increasing the production rate by fracturing, recompletion of a current or additional production zone, the introduction of artificial lift methods, or completing in additional production zones would not be considered a modification.

Note 3: For changes at existing facilities not involving new wells or added production from other wells, operators will be allowed 30 days from the date of the change to evaluate production/emissions, and 60 days from the date of the change to install controls if the change triggered a modification to the facility. For artificial lift, if production data gathered during the 30 days from the date of the change are not satisfactory to the operator, the artificial lift may be removed within 60 days from the date of the change without triggering a modification to the facility.

* to include existing controls on oil/condensate tanks and dehydration units if a facility includes both of these types of emission units, or controls on tanks for facilities with no dehydration units, or controls on dehydration units for facilities with no tanks.

Oil – Crude petroleum oil and any other hydrocarbons, regardless of gravities, which are produced at the well in liquid form by ordinary production methods, and which are not the result of condensation of gas before or after it leaves the reservoir.

Oil Well – A well, the principal production of which, at the mouth of the well, is oil, as defined by the Wyoming Conservation Law.

PAD – A PAD facility is a location where more than one well and/or associated production equipment are located, where some or all production equipment is shared by more than one well or where well streams from more than one well are routed through individual production trains located at the same or contiguous and adjacent location. If the production streams or production equipment associated with one or more wells is added to an existing single well facility, that location is then considered to be a PAD facility. A single well becomes a multiple well or PAD facility upon the First Date of Production of an additional well at the location or on the day production streams associated with an additional well or wells from separate locations are routed to the single well facility. A tank battery is not considered a PAD facility.

Potential to Emit – The maximum capacity of a stationary source to emit any air pollutant under its physical and operational design. Any physical or operational limitation on the capacity of a source to emit an air pollutant, including air pollution control equipment and restrictions on hours of operation or on the type or amount of material combusted, stored or processed, shall be treated as part of its design if the limitation is enforceable.

Recompletion – Any downhole operation in an existing oil or gas well that is conducted to establish production of oil or gas from any geological interval not currently completed or producing in said existing oil or gas well.

Single Well Facility – A single well facility is one where production equipment is associated with only one well. A single well becomes a multiple well or PAD facility upon the First Date of Production of an additional well at the location or on the day production streams associated with an additional well or wells from separate locations are routed to the single well facility.

Spud – The commencement of operations for the first boring of a hole for the drilling of an oil, gas or injection well. This includes setting conductor casing.

Tank Battery – An oil production facility with little to no produced gas that is comprised mainly of separators, heaters, and tanks. The facility does not use dehydration units. The API gravity of the produced oil is no higher than 25°.

VOC – Volatile organic compound is defined in 40 CFR §50.100(s), 51.100(s)(1), and 51,100(s)(5)

VOC Weight Percent – This is the weight of the volatile organic compounds, expressed as a percent, as compared to the total weight of the compounds in a gas stream. (This should not be confused with the volume or mole percent of a gas stream, which is usually how it is expressed in a lab analysis of a gas.)

Wildcat Well – Any oil or gas well designated as a wildcat well by the Wyoming Oil and Gas Conservation Commission. Wildcat wells are wells outside known fields or new wells which are determined by the Commission to have discovered oil or gas in a pool not previously proven productive.

Wyoming Environmental Quality Act – Wyoming Statute, Title 35 “Public Health and Safety”, Chapter 11 “Environmental Quality” which provides the authority for the rules and regulations of the Air Quality Division.

Zero bleed controller – Electric, air-driven, or solar powered controller that does not rely on natural gas to actuate.