

**From:** [BJ Kristiansen](#)  
**To:** [Kim Pandullo](#)  
**Subject:** TIPS class from 2015  
**Date:** Tuesday, April 11, 2017 10:58:32 AM

---

Kim,

?

I attended the TIPS Subsidence class in March, 2015. I have my manual from the class but I thought an electronic version was available. I've looked through my office but can't find one. Is it possible that you have a contact at OSM that I can use to find out whether a disc is available? The class was Subsidence (SUB-51). I've tried the OSM TIPS website but not having any luck. I need this for the Brook Mine hearing. I'm pathetic.

?

-bj kristiansen

**From:** [Smalls, Karen](#)  
**To:** [BJ Kristiansen](#)  
**Cc:** [Kim Pandullo](#)  
**Subject:** Re: TIPS class from 2015  
**Date:** Tuesday, April 11, 2017 3:21:15 PM  
**Attachments:** [Copy of Chapter 01 - Coal Mining Overview with References.pdf](#)  
[Copy of Chapter 02 - Mechanics of Subsidence with References.pdf](#)  
[Copy of Chapter 03 - Principle Parameters 2014 with References.pdf](#)  
[Copy of Chapter 04 - Structural Damage with References.pdf](#)  
[Copy of Chapter 05 - Subsidence Monitoring \(1\).pdf](#)  
[Copy of Chapter 06a - Subsidence Investigation Handout Slides \(2\).pdf](#)  
[Copy of Chapter 06b - Subsidence Investigation Tools Handout Slides.pdf](#)  
[Copy of Chapter 07 - Mitigation Measures.pdf](#)  
[Copy of Chapter 08 - Subsidence Prediction Methods with References.pdf](#)  
[Copy of Chapter 09 - Pillar Mechanics and Design with References.pdf](#)

---

See attachments.

If you have any questions, please contact me.

Thanks!

**Karen D. Smalls**

U. S. Department of the Interior  
Office of Surface Mining Reclamation and Enforcement (OSMRE)  
National Technical Training Program  
1951 Constitution Avenue, N.W.  
South Interior Building, Room 218  
Washington D.C. 20240

**Telephone:** (202) 208 - 0871  
**Fax:** (202) 219 - 3111  
**Email:** [ksmalls@osmre.gov](mailto:ksmalls@osmre.gov)

On Tue, Apr 11, 2017 at 3:31 PM, BJ Kristiansen <[bj.kristiansen@wyo.gov](mailto:bj.kristiansen@wyo.gov)> wrote:

Hay Karen, long time no...uhh..hear? Anyway, If you can get me an electronic copy of the 2015 book, great. If not, the new one will work OK. Thanks for the quick follow-up.

-bj kristiansen

**From:** Smalls, Karen [mailto:[ksmalls@osmre.gov](mailto:ksmalls@osmre.gov)]  
**Sent:** Tuesday, April 11, 2017 1:27 PM  
**To:** Kim Pandullo <[kim.pandullo@wyo.gov](mailto:kim.pandullo@wyo.gov)>  
**Cc:** John Leehang <[jleehang@osmre.gov](mailto:jleehang@osmre.gov)>; BJ Kristiansen <[bj.kristiansen@wyo.gov](mailto:bj.kristiansen@wyo.gov)>  
**Subject:** Re: TIPS class from 2015

Hi Kim/ BJ:

I will check to see if we have a copy of the SUB-51? If not, would an electronic copy of this year's class work?

If you have any questions, please contact me.

Thanks!

**Karen D. Smalls**

U. S. Department of the Interior  
Office of Surface Mining Reclamation and Enforcement (OSMRE)  
National Technical Training Program  
1951 Constitution Avenue, N.W.  
South Interior Building, Room 218  
Washington D.C. 20240

**Telephone:** (202) 208 - 0871

**Fax:** (202) 219 - 3111

**Email:** [ksmalls@osmre.gov](mailto:ksmalls@osmre.gov)

On Tue, Apr 11, 2017 at 1:06 PM, Kim Pandullo <[kim.pandullo@wyo.gov](mailto:kim.pandullo@wyo.gov)> wrote:

BJ Kristiansen attending the Sub-51 class back in 2015. Could you please see his request above and let us know if you can help or who I would need to talk to to get some help! Thanks.

**Thank you and have a wonderful day!!**

Kim Pandullo

**Administrators' Secretary  
Office Support Specialist II**

State of Wyoming

DEQ-Land Quality Division **Note: NEW ADDRESS**

200 W. 17th St., Suite 10

Cheyenne, WY 82002

[kim.pandullo@wyo.gov](mailto:kim.pandullo@wyo.gov)

(307) 777-7655

fax (307) 635-1784

\*\*\*\*\*Confidentiality Notice\*\*\*\*\*

This message and any attachments are only for the use of the intended recipient(s), are confidential, and may be privileged. If you are not the intended recipient, you are hereby notified that any review, retransmission, conversion to hard copy, copying, circulation or other use of all or any portion of this message and any attachments is strictly prohibited. If you are not the intended recipient, please notify the sender immediately by return e-mail, and delete this message and any attachments permanently from your system.

----- Forwarded message -----

From: **BJ Kristiansen** <[bj.kristiansen@wyo.gov](mailto:bj.kristiansen@wyo.gov)>  
Date: Tue, Apr 11, 2017 at 11:01 AM  
Subject: RE: TIPS class from 2015  
To: Kim Pandullo <[kim.pandullo@wyo.gov](mailto:kim.pandullo@wyo.gov)>

Thanks Kim, I appreciate it.

**From:** Kim Pandullo [mailto:[kim.pandullo@wyo.gov](mailto:kim.pandullo@wyo.gov)]  
**Sent:** Tuesday, April 11, 2017 11:00 AM  
**To:** BJ Kristiansen <[bj.kristiansen@wyo.gov](mailto:bj.kristiansen@wyo.gov)>  
**Subject:** Re: TIPS class from 2015

I will do what I can and let you know BJ.

**Thank you and have a wonderful day!!**

Kim Pandullo

**Administrators' Secretary  
Office Support Specialist II**

State of Wyoming

DEQ-Land Quality Division **Note: NEW ADDRESS**

200 W. 17th St., Suite 10

Cheyenne, WY 82002

[kim.pandullo@wyo.gov](mailto:kim.pandullo@wyo.gov)

[\(307\) 777-7655](tel:(307)777-7655)

fax [\(307\) 635-1784](tel:(307)635-1784)

**\*\*\*\*\*Confidentiality Notice\*\*\*\*\***

This message and any attachments are only for the use of the intended recipient(s), are confidential, and may be privileged. If you are not the intended recipient, you are hereby notified that any review, retransmission, conversion to hard copy, copying, circulation or other use of all or any portion of this message and any attachments is strictly prohibited. If you are not the intended recipient, please notify the sender immediately by return e-mail, and delete this message and any attachments permanently from your system.

On Tue, Apr 11, 2017 at 10:58 AM, BJ Kristiansen <[bj.kristiansen@wyo.gov](mailto:bj.kristiansen@wyo.gov)> wrote:

Kim,

I attended the TIPS Subsidence class in March, 2015. I have my manual from the class but I thought an electronic version was available. I've looked through my office but can't find one. Is it possible that you have a contact at OSM that I can use to find out whether a disc is available? The class was Subsidence (SUB-51). I've tried the OSM TIPS website but not having any luck. I need this for the Brook Mine hearing. I'm pathetic.

-bj kristiansen

E-Mail to and from me, in connection with the transaction of public business, is subject to the Wyoming Public Records Act and may be disclosed to third parties.

E-Mail to and from me, in connection with the transaction of public business, is subject to the Wyoming Public Records Act and may be disclosed to third parties.

E-Mail to and from me, in connection with the transaction of public business, is subject to the Wyoming Public Records Act and may be disclosed to third parties.

E-Mail to and from me, in connection with the transaction of public business, is subject to the Wyoming Public Records Act and may be disclosed to third parties.

E-Mail to and from me, in connection with the transaction of public business, is subject to the Wyoming Public Records Act and may be disclosed to third parties.

# **CHAPTER 1:**

## **SUBSIDENCE**

### **OVERVIEW**

#### **Review of Coal Mining Methods**

Kewal Kohli  
Stefanie Self

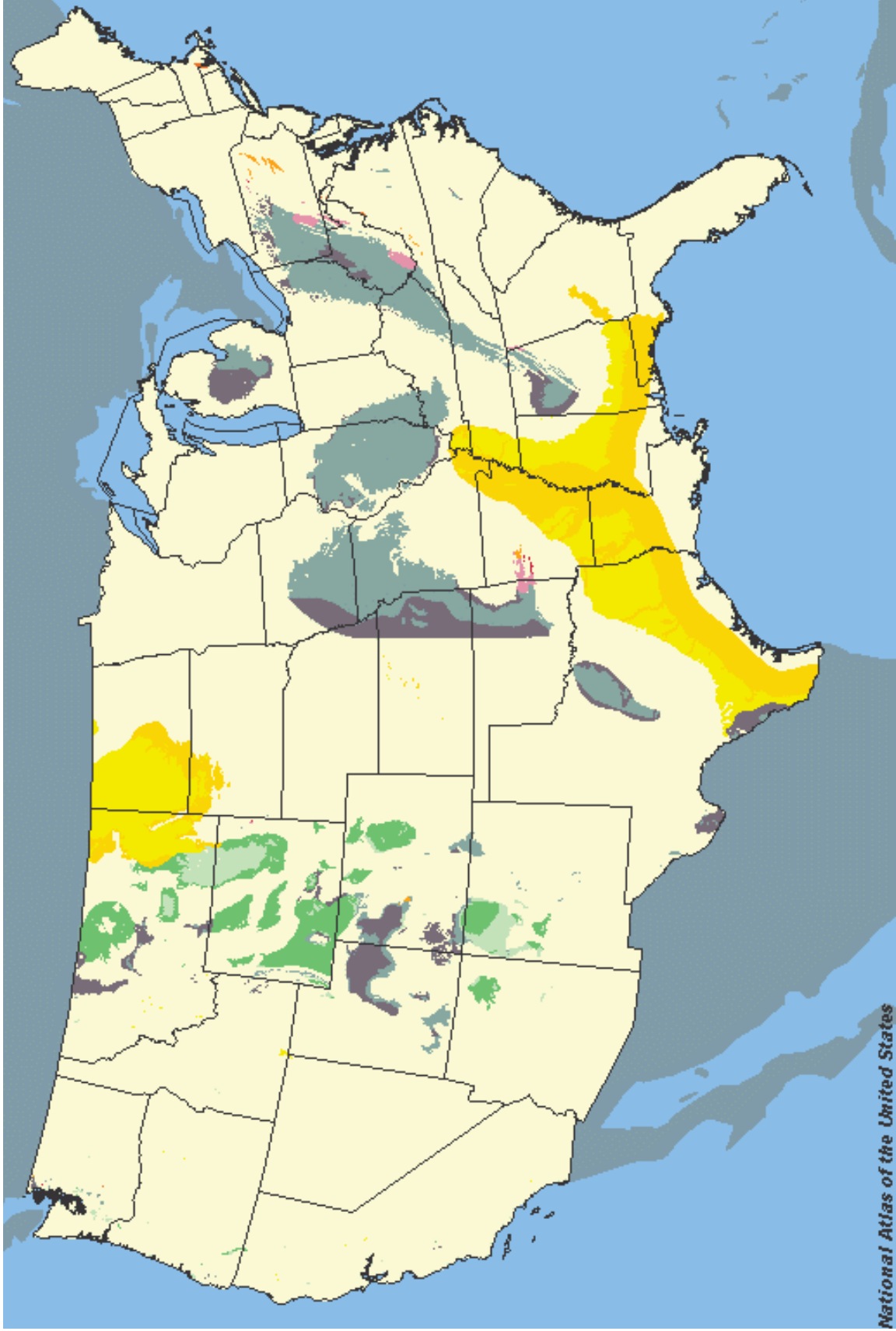

Figure 1: Map illustrating the various coalfields of the continental United States (from the USGS National Atlas).



**Table 1: Coal-Producing States 2013**

<b>Rank</b>	<b>State</b>	<b>Number of Mines</b>	<b>Production (thousand short tons)</b>	<b># of Underground Mines</b>	<b># of Surface Mines</b>
1	Wyoming	17	387,924	1	16
2	West Virginia	218	112,786	128	90
3	Kentucky	270	80,380	98	172
4	Pennsylvania	229	54,009	52	177
5	Illinois	24	52,147	15	9
6	Texas	11	42,851	0	11
7	Montana	6	42,231	1	5
8	Indiana	27	39,102	9	18
9	North Dakota	4	27,639	0	4
10	Ohio	31	25,113	10	21
11	Colorado	10	24,236	6	4
12	New Mexico	4	21,969	1	3
13	Alabama	39	18,620	8	31
14	Utah	9	16,977	8	1
15	Virginia	82	16,619	48	34
16	Arizona	1	7,603	0	1
17	Louisiana	2	2,810	0	2
18	Maryland	21	1,925	3	18
19	Mississippi	2	3,575	0	2
20	Alaska	1	1,632	0	1
21	Oklahoma	9	1,136	2	7
22	Tennessee	11	1,098	4	7
23	Missouri	1	414	0	1
24	Arkansas	2	59	1	1
25	Kansas	1	22	0	1

Table adapted from EIA's Annual Coal Report 2013 Table 1

## OVERVIEW OF COAL MINING METHODS IN THE UNITED STATES

Underground coal mining in the United States employs two basic methods of coal extraction: room-and-pillar mining and longwall mining. Auger mining is also employed where conditions are favorable for its application. These are briefly discussed within this manual, however, some other major references include: Peng, 2006; Stefanko, 1983; and Hustrulid, 1982.

### 1.1 Room-and-Pillar Mining (Figure 1.1)

Room-and-pillar mining is the predominant method of coal extraction in the United States. The room-and-pillar method in its basic form consists of driving entries, rooms and cross-cuts into the coal seam to extract coal. Pillars of coal are left to support the overburden. This procedure is also called "development" mining. Movements of the ground surface during this period are nearly always imperceptible. To increase the extraction of coal where conditions allow, the development mining is sometimes followed by "retreat mining", "pillar recovery" or "second mining", where the pillars are systematically extracted. Pillar extraction is invariably accompanied by subsidence of the ground surface as the overburden sags into the mined-out area in response to the removal of mine level support. Where pillar extraction is not conducted and permanent surface support is intended, the pillars must be designed to permanently support the ground surface.

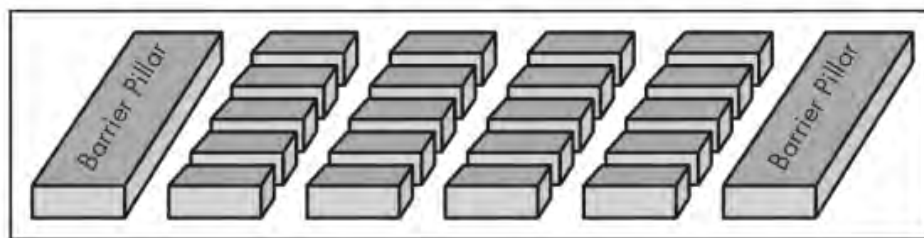

Figure 1.1 showing Room-and-Pillar mining layout with five entries (Darling 2011)

The two broad categories of room-and-pillar mining are "conventional" and "continuous"--the distinction being based on differences in machinery and mining methods at the face. The following brief descriptions serve to illustrate the basic characteristics of each category. Details with regard to cutting and conveying the coal vary from mine to mine.

#### 1.1.1 Conventional Mining

In "conventional" room-and-pillar mining (Figure 1.1.1a), coal was recovered by first cutting a horizontal slot 10 to 12 feet deep at the bottom of the coal seam (Figure 1.1.1b). The face is then pattern-drilled with blast holes designed to produce an 8- to 10-foot deep cut. After detonation of the explosives, the fragmented coal is loaded and transported out by one of various means (e.g., shuttle cars (Figure 1.1.1c), belt) and the roof is supported in accordance with roof control plans approved. Within the US, this method has mainly given way to the Continuous Mining Method explained next.

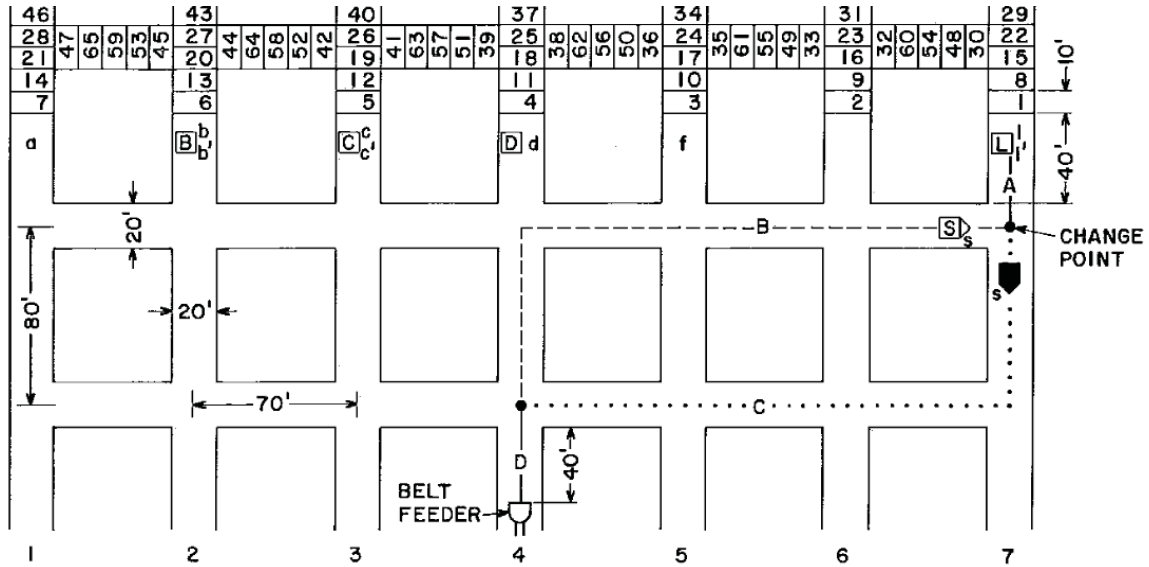

Fig. 1. Conventional mining plan. Legend:

**Equipment Deployment**

- L Loading machine
- S Shuttle car
- D Mobil coal drill
- C Cutting machine
- B Bolting machine

**Manpower Assigned**

- s Shuttle car operator
- 1,1' Loading machine operator, helper
- f Shot fireman
- d Drill operator
- c,c' Cutting machine operator, helper
- b,b' Bolters
- a Auxiliary or utility man
- 11 Men total

Fig. 1.1.1a Conventional Mining Section (Stefanko 1983)



©2008 Joy Mining Machinery

Fig. 1.1.1b Conventional Mining Equipment - Cutting Machine (Joy Mining Machinery Website)



Fig. 1.1c Conventional Mining Equipment - Shuttle Car (Joy Mining Machinery Website)

### **1.1.2 Continuous Mining**

In "continuous" room-and-pillar mining (Figure 1.1.2a), coal is recovered using a continuous mining machine (Figures 1.1.2b & 1.1.2c). This machine breaks coal off the face through a mechanical action and eliminates the need for drilling and blasting. The coal is then passed to a shuttle car (Figure 1.1.2d), which moves the coal to a nearby conveyor belt.

During development mining, rooms are driven on regular spacings from the main entries to the far end of the mine panel. The rooms are connected by cross-cuts to form a pattern of coal pillars that is commonly orthogonal in plan. Cross-cuts are occasionally driven oblique to the entries to facilitate movements of mine equipment and for ventilation. Thirty to fifty percent of the coal may be extracted from the panel during development.

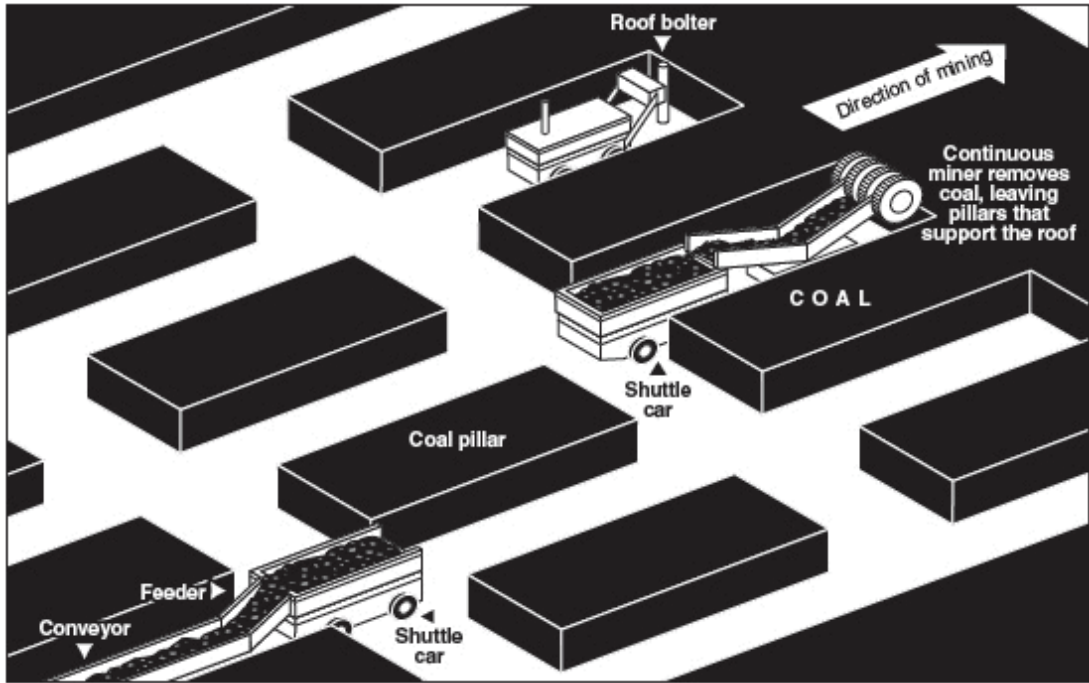

Fig. 1.1.2a Continuous Mining Section (Patriot Coal Website)



Fig 1.1.2b – Continuous Mining Machine (Joy Mining Machinery Website)



*Rapid change  
of cutting heights*

Fig 1.1.2c – Continuous Mining Machine (Caterpillar 2011)



©2008 Joy Mining Machinery

Fig 1.1.2d – Shuttle Car (Joy Mining Machinery Website)

For both conventional and continuous methods, temporary supports (hydraulic posts, screw jacks, or wood posts/cribs Figure 1.1.2e) are often set in conjunction with coal extraction. Expansion-anchor roof bolts or resin grouted bolts are commonly used for permanent roof support (Figure 1.1.2f).



Fig 1.1.2e – Crib blocks (Darling 2011) and Jack Support (Gilmore-Kramer)



RamTrak 2300

Multibolter

Fig 1.1.2f – Roof Bolting Machines (Joy Global *Mobile Bolters* 2012)

In order to prevent subsidence, this may be all the coal recovered from a mine so as to prevent any surface subsidence. In other areas, there may be an attempt to recover some of the coal pillars, which can increase recovery to 80 percent. This is called retreat mining.

### 1.1.3 Retreat Mining

During pillar retreat mining, pillars are systematically removed along a common front (pillar line) that sweeps across the panel from end to end. Pillars are generally recovered on retreat - that is, as mining progresses from the far end of the panel back-towards the main entries.

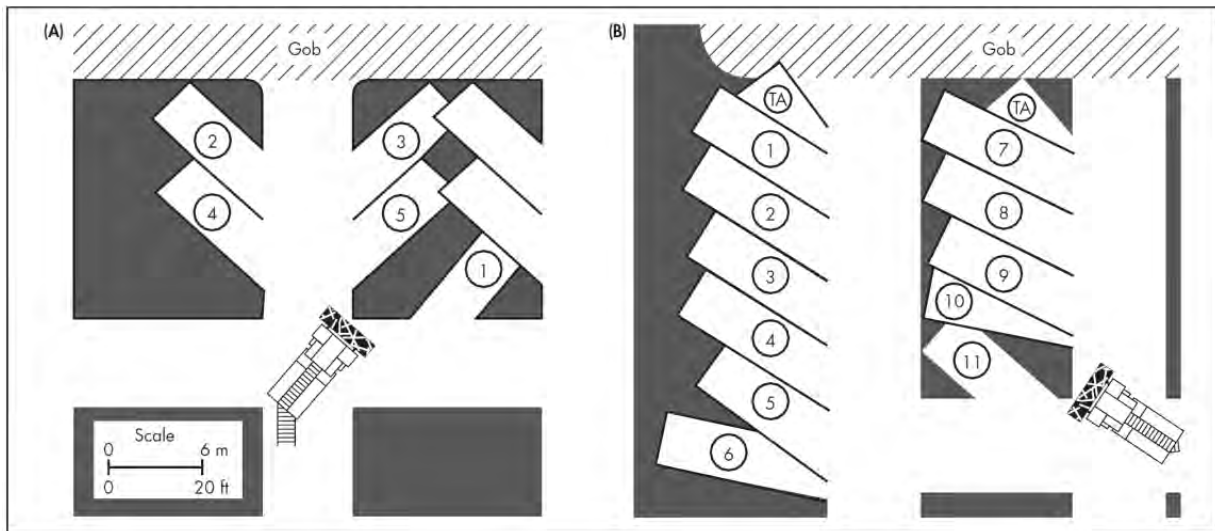

Fig. 1.1.3a Retreat Mining (Darling 2011)

Usually, some stumps of coal are left in place for safety reasons. With time these stumps often crush and cause the overlying strata to move down and eventually appear as uneven subsidence on the surface. In such cases the subsidence will be delayed and unpredictable.

### 1.2. Longwall Mining (Figures 1.2.1 & 1.2.2)

Longwall mining has a long history of use in Europe and was tried at various times in the United States. In early attempts--some prior to 1900--labor costs associated with moving manual supports made the method uncompetitive relative to room-and-pillar mining. This method requires a uniform coal seam (flat, relatively consistent thickness and quality), and a high upfront capital investment. However, it has become ever more popular in United States coal mines since the 1970's, with a peak number of 118 longwall faces in 1982 and 1984 (Peng 2006). There has been a decrease since the early 1980s, with a current number of 48 longwalls in operation (Fiscor 2013).

The development of main entries for access and ventilation is essentially identical to development during room-and-pillar mining. Thereafter, groups of parallel entries are driven perpendicular to the main entry on either side of the proposed extraction area (called a panel). The width of panel varies from 1000 to 1500 feet, and length from 10,000 to 18,000 feet (Figure 1.2.1). The coal is cut by a shearer (Figures 1.2.3 & 1.2.4) or plow (Figure 1.2.5) which travels up and down along the face. The broken coal falls on to a chain conveyor which transfers on to a belt conveyor and is conveyed to the surface through several belt conveyors (Fig 1.2.2).



Hydraulic self advancing shields support the roof at the immediate face as the coal is removed. As the face advances, the roof strata is allowed to cave in behind the shields; and results in smooth surface subsidence within four to six weeks. This is planned surface subsidence, and is predictable and well-studied.

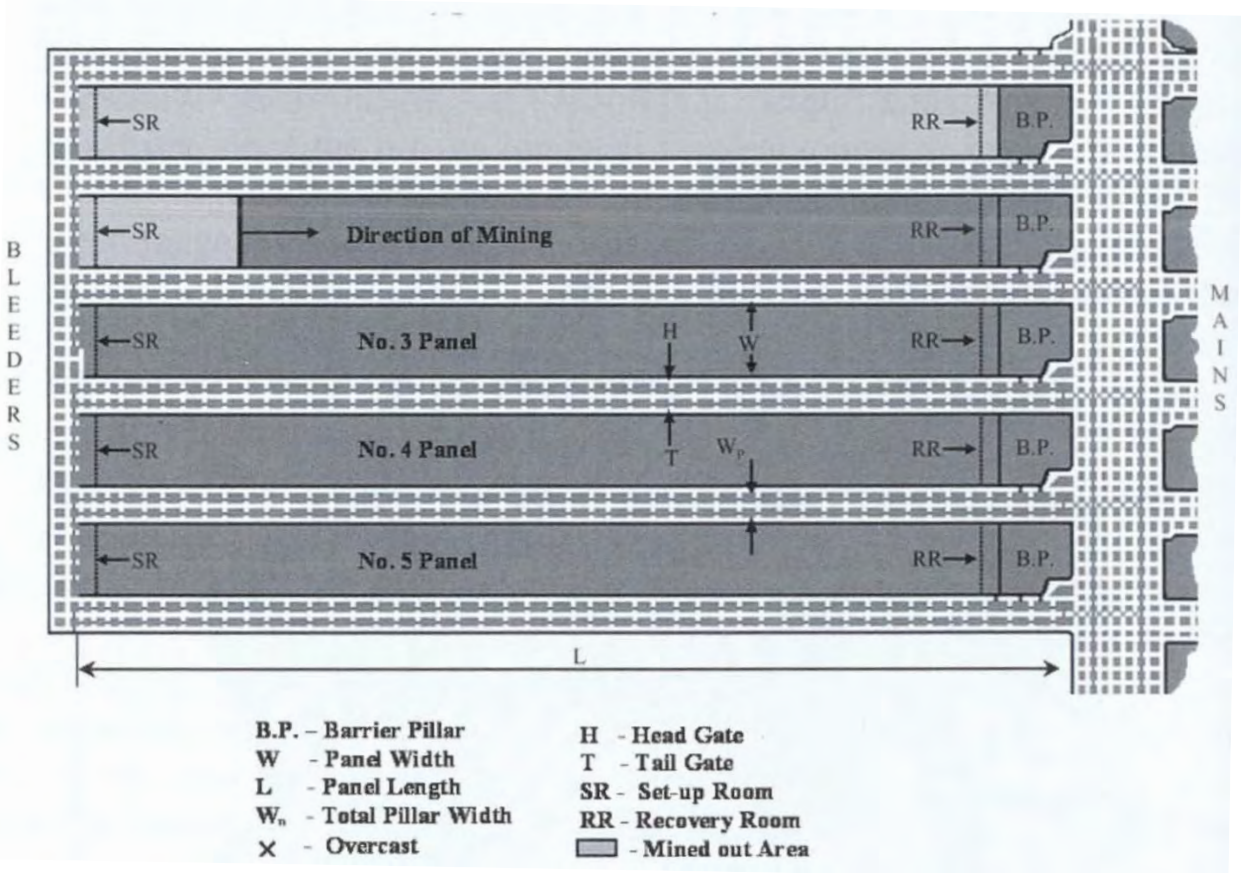

Fig 1.2.1 Typical US Longwall Panel Layout (Peng 2006)

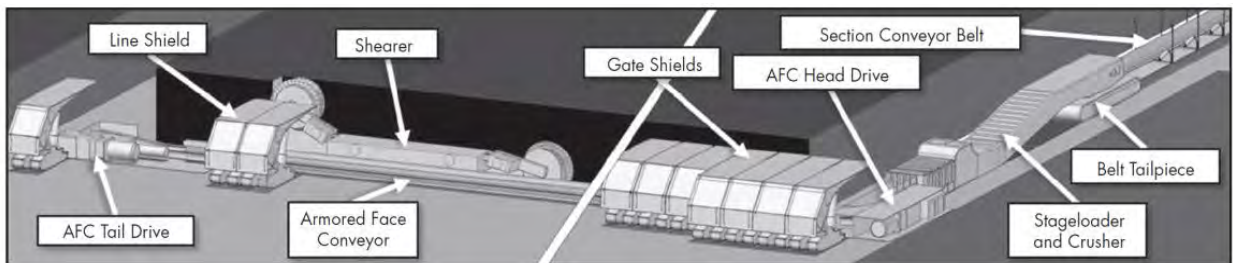
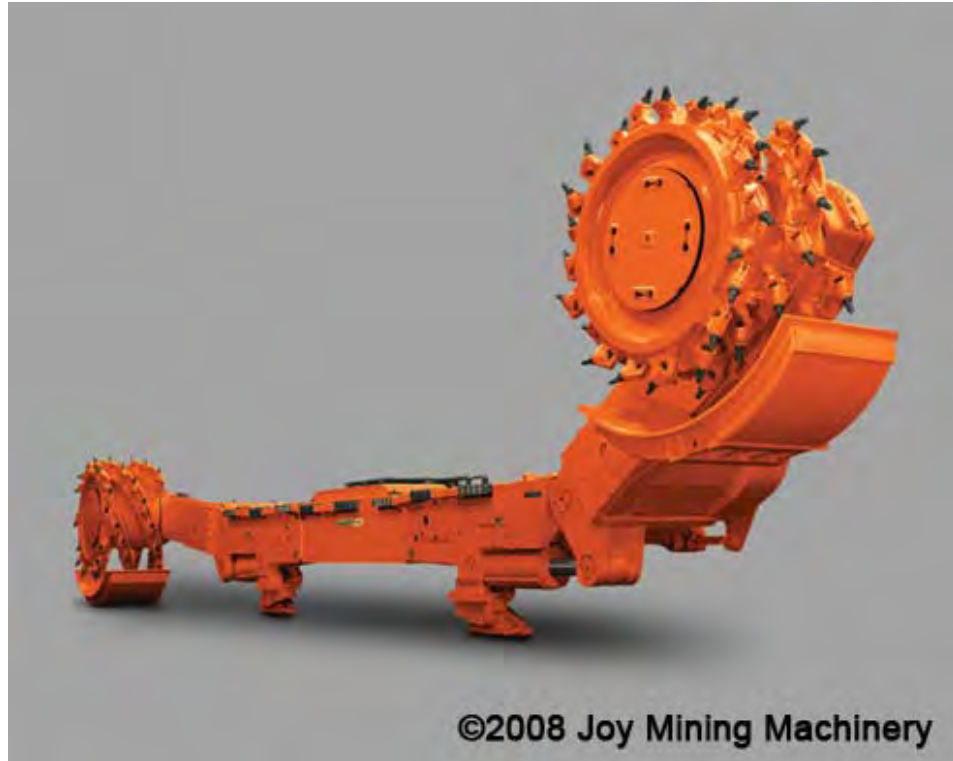

Fig. 1.2.2 Longwall Mining Equipment (Darling 2011)



©2008 Joy Mining Machinery

Fig 1.2.3 – Joy Longwall Shearer (Joy Mining Machinery Website)



Fig 1.2.4 – Caterpillar Shearer and Shields for Longwall Mining (Caterpillar 2011)



Fig 1.2.5 – Caterpillar Plow Longwall Machine (Caterpillar 2011)



## Roof Supports

Fig 1.2.6 – Roof Supports with Conveyor (Joy Global *Longwall Systems* 2012)

Table 2 - Longwall Installations, by Parent Company (2015-2016)												
Company	AL	CO	IL	MT	NM	OH	PA	UT	VA	WV	WY	Total
Alliance Resource Partners			1							2		3
AmCoal			2									2
American Energy						1						1
Arch Coal		1								2		3
Blue Mountain Energy		1										1
Bowie Resources Partners		2						2				4
CONSOL Energy							5		1			6
Drummond	1											1
ERP Compliant Fuels										2		2
Foresight Energy			4									4
Murray American Energy										6		6
Ohio Valley Coal						1						1
Pacific Minerals											1	1
Seminole Coal Resources	3											3
Seneca Coal Resources	1											1
Signal Peak Energy				1								1
Solvay Chemicals											1	1
Tronox Alkali Co.											1	1
UtahAmerican Energy Inc								1				1
Westmoreland Coal					1							1
<b>Total</b>	<b>5</b>	<b>4</b>	<b>7</b>	<b>1</b>	<b>1</b>	<b>2</b>	<b>5</b>	<b>3</b>	<b>1</b>	<b>13</b>	<b>3</b>	<b>45</b>

Table taken from Coal Age Magazine, February 2016

### 1.3. Auger and Highwall Mining (Figure 1.3)

Auger and highwall mining are used in conjunction with surface mining when the overburden strata approaches the economic limits of using surface mining method or the area is not large enough to justify a deep mine.

A coal auger can be compared to a wood auger, as the auger rotates it brings the coal out along the spiral of the auger. Mining recovery averages 40 to 60 percent and penetration ranging from 300- to 500- feet deep have reported (Darling 2011).



Fig Auger Mining (from Contour Highwall Mining website)

Highwall mining is similar to auger mining except the auger is replaced by a thin-seam miner. A thin-seam miner is a modified continuous miner which is operated from the surface. The machine makes a wide cut and the broken coal is conveyed from the hole by a conveyance system. Coal recovery has been improved with this system, up to 70 percent, with penetrations of up to 1,640 ft (Darling 2011).

Surface subsidence potential does exist in spite of low mining recovery because of faster deterioration of narrow ribs left in-place between auger holes.



Fig Highwall Miner Machine (Caterpillar 2013)

## References, Chapter 1

Brown, B. H. G. & Brown, E. T. 1992. *Rock Mechanics for Underground Mining, 2<sup>nd</sup> Edition*. London: Chapman & Hall.

Caterpillar, Inc. 2013. *HW300 – Highwall Mining System*. Retrieved from <https://mining.cat.com/products/surface-mining/highwall-miner>

Caterpillar, Inc. 2011. *Longwall Mining Equipment – Product Line Overview*. Retrieved from <https://mining.cat.com/products/underground-mining/longwall>

Caterpillar Website. 2013. <https://mining.cat.com/>

Coal Age Magazine, February 2016. <http://www.coalage.com/>

Contour Highwall Mining Website. 2013. <http://www.northsidedevelopment.com/contourmining.com/BundyAuger.html>

Darling, P. (Ed.) 2011. *SME Mining Engineering Handbook, 3<sup>rd</sup> Edition*. Denver, CO. Society for Mining, Metallurgy, and Exploration, Inc.

Berkhimer, E.N. *Chapter 10.10 – Highwall Mining*.

Bessinger, S.L. *Chapter 13.8 – Longwall Mining*.

Harrison, J.P. *Chapter 8.9 – Mine Subsidence*.

Tien, J.C. *Chapter 13.2 – Room-and-Pillar Mining in Coal*.

Fiscor, S. (2013, February). America's Longwall Operations Demonstrate Stability During an Uncertain Period. *Coal Age*, 24-25.

Hustrulid, W. A. (Ed.). 1982. *Underground Mining Methods Handbook*. New York: Society of Mining Engineers.

Gilmore-Kramer Company Website

[http://www.gilmorekramer.com/more\\_info/mine\\_roof\\_supports/mine\\_roof\\_supports.shtml](http://www.gilmorekramer.com/more_info/mine_roof_supports/mine_roof_supports.shtml)

Joy Global. 2012. *Mobile Bolters – Product Overview*. Retrieved from <http://www.joy.com/en/Joy/Products/Bolting-Solutions.htm>

Joy Global. 2012. *Longwall Systems – Product Overview*. Retrieved from <http://www.joy.com/Joy/Products/Longwall-Systems.htm>

Joy Machinery Company. 1979. *An Introduction to Longwall Mining*. USA, Joy Machinery Company Customer Training Center.

Joy Mining Machinery Website. 2013 <http://www.joy.com/>

Kentucky Coal Website. 2013. <http://www.uky.edu/KGS/>

Mark & Tuchman. 1997. *Information Circular 9446 – Proceedings: New Technology for Ground Control in Retreat Mining*.

Mark, Chase & Pappas. 2003. *Reducing the Risk of Ground Falls During Pillar Recovery* (Included in the Reference files for the Analysis of Retreat Mining Pillar Stability (ARMPS) computer program provided by NIOSH).

National Coal Board. 1975. *Subsidence Engineers' Handbook*. London: National Coal Board, Mining Department.

NIOSH. 2006. Technology News No. 516: *ARMPS-HWM: New Software for Sizing Pillars for Highwall Mining*.

Patriot Coal Website. 2013. <http://www.patriotcoal.com/index.php?view=how-we-mine&p=3&s=52>

Peng, S. S. 2006. *Longwall Mining, 2<sup>nd</sup> Edition*. West Virginia: West Virginia University.

Stefanko, R. 1983. *Coal Mining Technology Theory and Practice*. New York: Society of Mining Engineers.

US Department of Energy, Energy Information Administration. 2015. *Annual Energy Review 2013*. Retrieved from <http://www.eia.gov/coal/annual/>

You Tube videos from various sources, listed by subject:

Auger Miner: <http://youtu.be/niLtVhDHIs0>

Caterpillar Machinery (<http://www.youtube.com/catmining>):

Principles of Room and Pillar Mining: <http://youtu.be/MCNjcNMojYQ>

Principles of Longwall Mining: <http://youtu.be/bXORrVmxwbM>

Longwall Mining Systems: <http://youtu.be/xNZqQrh2nAO>

Highwall Mining: <http://youtu.be/sETq5IVsY1E>

Highwall Mining

ADDCAR System <http://www.youtube.com/user/addcarsystems>

Joy Mining Machinery (<http://www.youtube.com/user/JoyMiningMachinery>):



Continuous Miners: <http://youtu.be/jPycLDKIGVw>

Longwall Mining System: <http://youtu.be/ijly1PUU7EY>

Pioneering Underground Mining: <http://youtu.be/649dZPCTD30>

Modern Marvels, Coal Mine Documentary: <http://youtu.be/futGoPygohl>

PBS "Where does our coal come from?": <http://youtu.be/W4a3AzDYm2M>

"Reflections" Mining History: <http://youtu.be/sjFENMBY4cM>

Zipf, R.K., Jr. 2005. Ground Control Design for Highwall Mining. SME Preprint 05-82. Littleton, CO: SME.

Zipf, R.K., Jr. and Bhatt, S. 2004. *Analysis of Practical Ground Control Issues in Highwall Mining*. In *Proceedings of the 23<sup>rd</sup> International Conference on Ground Control in Mining*. Morgantown, WV.

**CHAPTER 2:**

**MECHANICS**

**OF**

**SUBSIDENCE**

Kewal Kohli  
Stefanie Self

# MECHANICS OF SUBSIDENCE

## 2.1 SUBSIDENCE TERMS

### 2.1.1 TYPES OF SUBSIDENCE

Whenever a cavity is created underground, due to the mining of minerals or for any other reason, the stress field in the surrounding strata is disturbed. These stress changes produce deformations and displacements of the strata, the extent of which depends on the magnitude of the stresses and the cavity dimensions. Mine subsidence may be defined as the ground movements that occur due to the collapse of the overlying strata into mine voids. Surface subsidence generally entails both vertical and lateral movements (Hartman 1992).

Subsidence can be classified into two types – continuous and discontinuous, or also as planned and unplanned subsidence. Typically, continuous subsidence is planned, while discontinuous subsidence is unplanned. Due to the unpredictability of discontinuous subsidence, typical work on these events is more reactive than proactive, and is covered in more detail in the NTTP AML Workshop on Subsidence. In this course, we will focus mainly on the continuous and predictable types of subsidence associated with current, active coal mines.

#### *Discontinuous vs Continuous Subsidence*

- Discontinuous Subsidence  
Difficult to predict, is usually caused by failure of voids in older mines. Can also be caused by pillar, roof or floor failure.
- Continuous Subsidence  
Fairly easy to predict, this type of subsidence occurs almost immediately following mining of a high percentage of the coal seam.

#### *Planned vs Unplanned Subsidence*

- Planned Subsidence  
Lowering of the ground surface in a predictable manner - predictable (within limits) as to a real extent, amount of subsidence and amount of ground surface distortion -- as a result of mining.
- Unplanned Subsidence  
Lowering of the ground surface in a manner that cannot be predicted as to a real extent, amount of subsidence or amount of ground distortion, as a result of failure at mine level of the overburden support system (coal pillars/mine roof/mine floor) or as a result of the action of other unanticipated causes, such as the piping of unconsolidated sediments into the mine.

In either case, the geometry of the subsidence trough is governed in varying degrees by the thickness of the overburden, the strength and deformability of the overburden strata, coal pillars and mine roof and floor, and the dimensions and geometry of the mined out area.



# Illustrated Effects of Mine Subsidence

## Mine Drainage

Mine drainage occurs when old underground mine workings gradually fill up with water, and the water breaks out onto the ground surface usually near a coal outcropping on or near a hillside. Sometimes heavy rains or melting snow can raise the water level in a mine and trigger a mine water breakout.

If such a breakout occurs suddenly and unexpectedly near a building, substantial damage can occur. Although this is not considered mine subsidence, under certain circumstances, building damage from such a mine water breakout would be covered by Mine Subsidence Insurance.



## Sinkhole Subsidence

Sinkhole subsidence occurs in areas overlying underground mines which are relatively close to the ground surface. This type of subsidence is fairly localized in extent and is usually recognized by an abrupt depression evident at the ground surface as overburden material collapses into the mine void. Sinkhole subsidence is perhaps the most common type of mine subsidence and has been responsible for extensive damage to many structures throughout the years.



Illustration of Sinkhole Subsidence.

## Trough Subsidence

Subsidence troughs over abandoned mines usually occur when the overburden sags downward due to the failure of remnant mine pillars or by punching of the pillars into a soft mine roof or floor. The resultant surface effect is a large, shallow yet broad depression in the ground which is usually elliptical or circular in shape.



Illustration of Trough Subsidence.

Subsidence is usually greatest at the center of the trough and it progressively decreases until the limit of the impacted surface area is reached. Horizontal ground movements also occur within a subsidence trough. Structures near the center of the trough



The illustration depicts the typical surface effects of mine subsidence. It is important to note that mine subsidence can occur as a result of mining at any depth. As a general rule, the coal surface area affected by subsidence increases as the depth of mining increases. This means a structure can be damaged by subsidence even if it is located directly above a pillar of solid block of coal.



Fig 2.1 Illustrated Effects of Mine Subsidence (PA DEP MSI Website)

## 2.1.2 FACTORS CONTROLLING HEIGHT OF THE CAVED AND FRACTURED ZONES

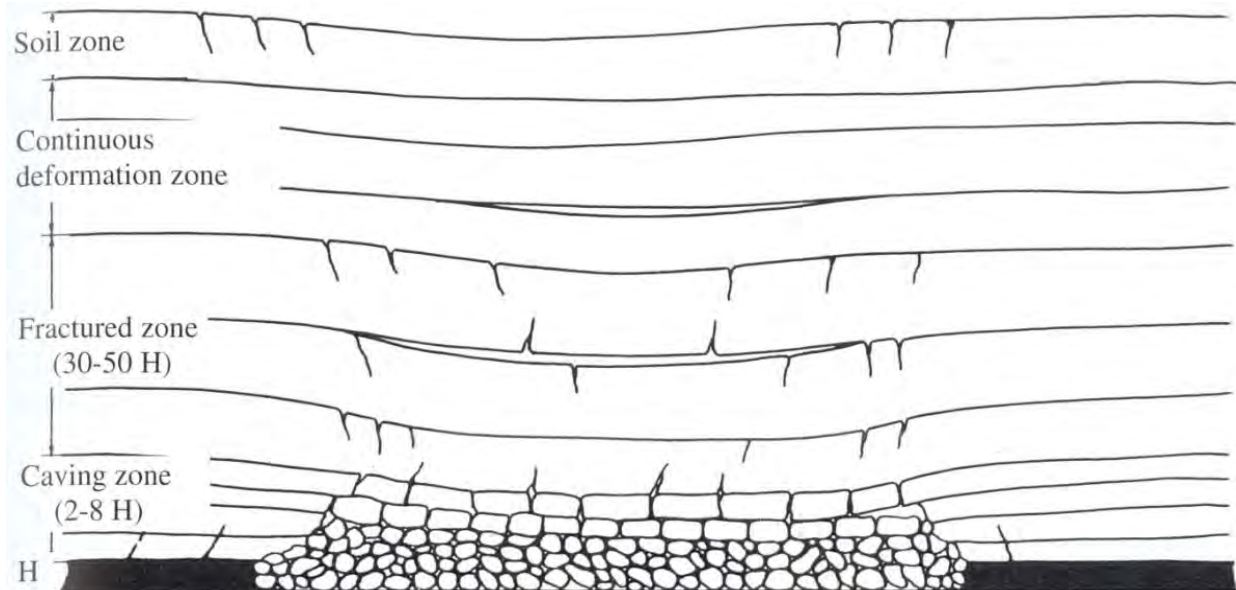

Fig 2.1.1 – Overburden Movement (Peng 2006)

Surface subsidence manifests itself in three major ways:

- 1) Cracks, fissures or step fractures
- 2) Pits or sinkholes (also called chimney subsidence)
- 3) Troughs or sags

Many geological and mining parameters affect the magnitude and extent of subsidence (Darling 2011).

- **Extraction Thickness/Mining Height**  
The thicker the material extracted, the larger the amount of possible surface subsidence. Note that it is the actual extracted thickness, not the in-situ thickness that must be considered. Where mining takes place in several overlying mining horizons, subsidence is related to both the total extracted thickness and the sequence of horizon extraction.
- **Mining Depth/Overburden Depth**  
The magnitude and time to onset of subsidence are dependent on depth.
- **Inclination of Extraction Horizon (Dip of coal seam)**  
Asymmetric subsidence occurs when the zone being mined is inclined. Subsidence becomes skewed and mitigation measures such as pillars become less effective. The subsidence profile is translated in a downdip direction with both the limit angle and the horizontal strains increased downdip and reduced updip.
- **Degree of Extraction (Percent Extraction, see below and Figure 2.2)**  
Reducing the amount of material extracted will reduce the amount of subsidence. Thus, lower extraction ratios tend to both reduce and delay the onset of subsidence.
- **Mined Area**

The critical width of a mined void must be exceeded in all directions if maximum subsidence is to develop.

- **Method of Working (Mining Method)**

The amount of subsidence is largely controlled by the degree of caving induced by the mining method, together with the amount of support offered by any backfilling. Nearly immediate, but predictable, subsidence occurs with longwall mining, whereas with Room-and-Pillar operations both the magnitude and onset of subsidence are largely unpredictable.
- **Extraction Rate**

Surface subsidence follows the face as it progresses, and so to minimize the effect of strain and tilt on surface structures, a fairly rapid, constant face advance rate should be adopted
- **Competence of Surrounding Materials (Rock Properties)**

Since subsidence propagates from the mine level, the mechanical behavior of the rock adjacent to the mined void directly affects the initiation of subsidence. Weak roofs and floors accentuate subsidence, whereas strong materials can delay or even prevent collapse and hence subsidence. Strong, massive materials above the mine level are able to withstand the effects of extraction for a prolonged period and hence defer the occurrence of subsidence.
- **In-Situ Stress State**

High horizontal stresses may foster formation of an arch in the material overlying a mined void, thereby attenuating subsidence. However, arch formation is a complex phenomenon, depending on many geomechanical parameters: It cannot be guaranteed, and arches may fail suddenly and catastrophically.
- **Geological Discontinuities**

The existence of faults, folds, and the like may increase and localize subsidence potential so strongly that in areas of adverse geological conditions the effects of the other parameters can be discounted.
- **Near-Surface Geology and Surface Topography**

The nature of any near-surface soils and unconsolidated rocks affects subsidence development, with both the thickness and mechanical characteristics of these materials being important. For example, cracks and fissures may form in stiff clays, whereas soft clays may deform plastically and cohesionless sands may flow down into fractures in the underlying rocks.
- **Hydrogeology**

Deformation of the strata around mined areas may alter hydraulic gradients, resulting in either the flooding or draining of surface areas and the formation or draining (in aquifers) of underground reservoirs.
- **Elapsed Time**

Subsidence does not occur instantaneously but over a period of time. In Room-and-Pillar operations, subsidence may only develop a long time (possibly centuries) after the mining is complete, when pillar degradation leads to roof collapse. In caving operations, surface displacements may occur almost immediately after the face passes below an area. However, as noted, the presence of strong, competent layers overlying an opening can delay this.

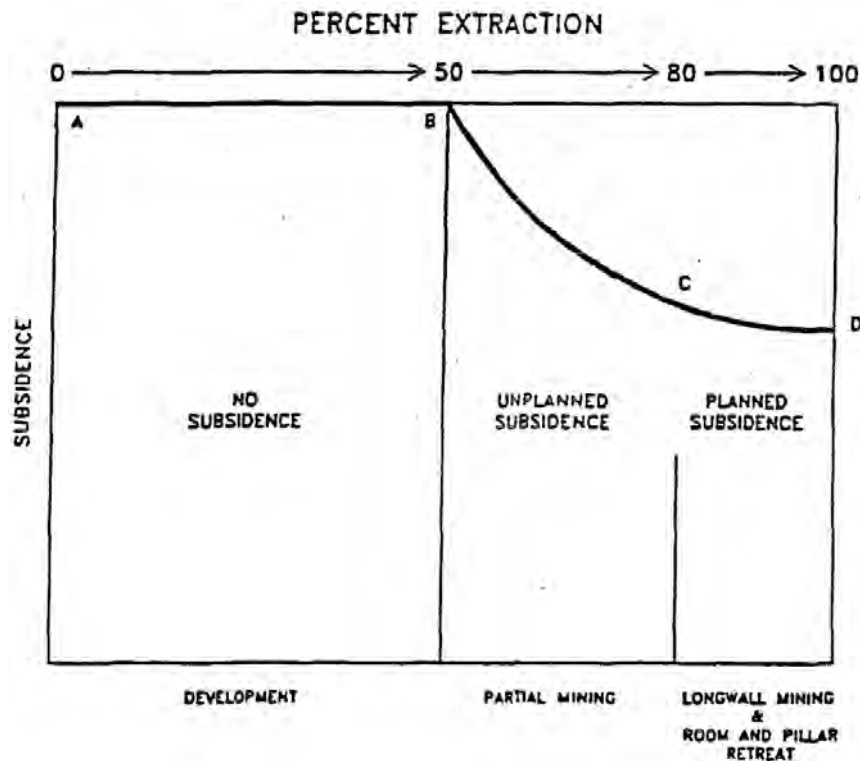

Fig 2.1.2 Schematic of relationship between subsidence and percent extraction (OSM 1988)

### Relationship Between Subsidence and Percent Extraction

The relationship between surface subsidence and percent extraction is shown in Figure 2.2. Permanent ground support (no subsidence) is denoted by the range A-B; impermanent ground support (some subsidence given a sufficient period of time) by the range B-C; and essentially total withdrawal of support (maximum subsidence), by the range C-D. Curve ABCD serves as a basis for the discussion that follows and is to be recognized as but one of a family of curves governed by panel geometry, overburden lithology, mine depth and mining pattern.

When the percent of extraction of coal from a mine panel is low to moderate (A-B), as is usual during developmental mining, the loads imposed upon the pillars by the overburden are generally small in relation to the size of the pillars. In this situation, subsidence of the ground surface is virtually nil and will remain so over the long term. Subsidence (such as it is) results primarily from the elastic compression of the coal pillars. In contrast, when the percent extraction is high, approaching 100 percent, as is the case during longwall or room-and-pillar retreat mining (C-D), subsidence above the panel approaches the maximum possible for the particular panel geometry and overburden lithology and results primarily from the overburden sagging down into the mined-out area, coming to rest on and compressing the rubble from the now broken mine roof.

Where partial extraction room-and-pillar mining is practiced, an intermediate condition may exist (B-C). Here, the recovery of coal by such methods as slabbing or splitting

pillars, although not attaining total extraction, may increase extraction to relatively high levels. If the panel has not yet been designed for permanent support, delayed subsidence of variable magnitude may eventually occur as a result of crushing of the coal pillars, failure of the mine roof or punching of the pillars into the mine floor. The result could be unexpected damage to structures at ground surface or, in areas of flat terrain, the pending of water above the panel.

The implication of these data is that ground movements associated with unplanned subsidence can be as significant as those associated with planned subsidence. The difference is, with unplanned subsidence, one cannot be certain as to when or where the subsidence will occur. Thus, in order to meet the requirements of subsidence control, the intermediate range of extractions must generally be avoided in modern mining. One should design either for no subsidence (Zone A-B) by providing permanent pillar support or for the maximum subsidence attainable relative to panel geometry and overburden lithology (Zone C-D), by extracting virtually all of the coal and causing subsidence to take place concurrently with mining.

### **2.1.3 DURATION OF SUBSIDENCE**

#### ***Active vs Residual***

The duration of subsidence resulting from mining is composed of two distinct phases: active and residual (Darling 2011).

- Active (or Dynamic) Subsidence  
Consists of those movements occurring contemporaneously with mining operations.
- Residual (or Static) Subsidence  
Consists of those movements that occur either following the cessation of mining or the passing of a zone of influence.

### **2.2 Discontinuous Subsidence**

Within the coal mining industry, discontinuous subsidence is usually expressed as chimney or sinkhole subsidence features. These are usually caused by the progressive migration of an unsupported mining cavity through the overlying material to the surface. Pillar collapse in old, shallow workings may lead to similar surface disturbances, but may lead to progressive failure and a wider affected area.



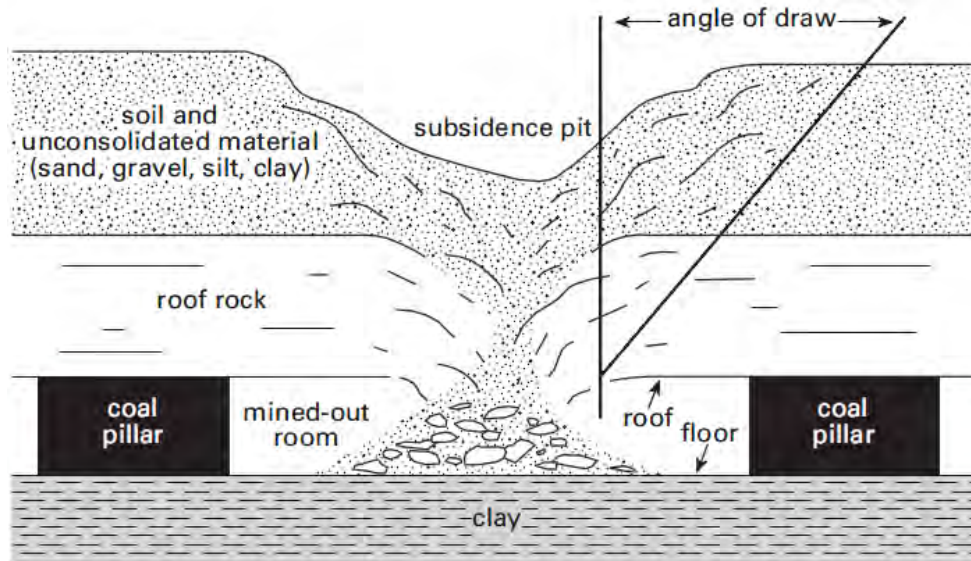

Fig 2.2.1 Diagram of typical subsidence from a mine roof collapse (Crowell 2010)



Fig 2.2.2 Subsidence hole (Crowell 2010)

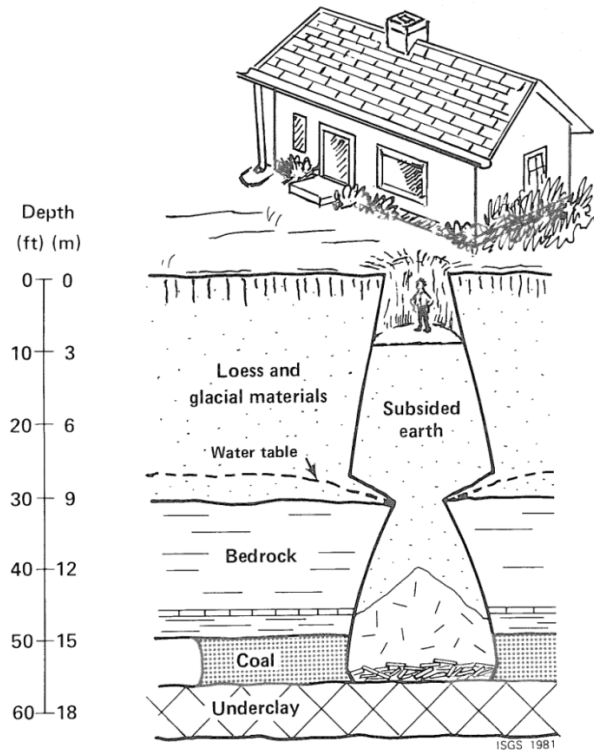

Fig 2.2.3 Cross Section of Typical Pit Subsidence (Bauer & Hunt 1981)

## 2.3 Continuous Subsidence

After the extraction of a longwall panel or room and pillar section with retreat mining (greater than 80 percent recovery) of sufficient width, the strata in the overburden are subjected to various degrees of movement from the bottom to the top. According to the movement characteristics, the damaged overburden can be divided into four zones (Figure 2.3.1).

- **Caved Zone**  
After the extraction of coal, the immediate roof caves irregularly and fills up the void. The strata in this zone not only lose their continuity; they also lose their stratified bedding. The caved zone is normally 2 to 8 times the mining height depending on the properties of the immediate roof and the overburden.
- **Fractured Zone**  
This zone is located immediately above the caved zone. The basic characteristics are strata breakage, and loss of continuity, but the stratified bedding remains. The severity of the strata breakage reduces from the bottom to the top. The porosity and permeability of the strata will increase greatly. The combined height of the fractured zone and caved zone is in general 20 to 30 times the mining height. The height of the fractured zone for hard and strong strata is larger than that for soft and weak ones.
- **Continuance Deformation Zone**  
Here the strata between the fractured zone and the surface bend downward without breaking. Their continuity and thus the original features remain. There may be some open fissures in the tension zone of the surface subsidence

- profile that do not destroy the strata continuity.
- Soil Zone  
This zone consists of soil and weathered rocks. Depending upon the physical properties of the soil, cracks may appear when the face is nearby and close back when the face has passed. However, some cracks and especially those along the edges of the panel may remain open after mining.

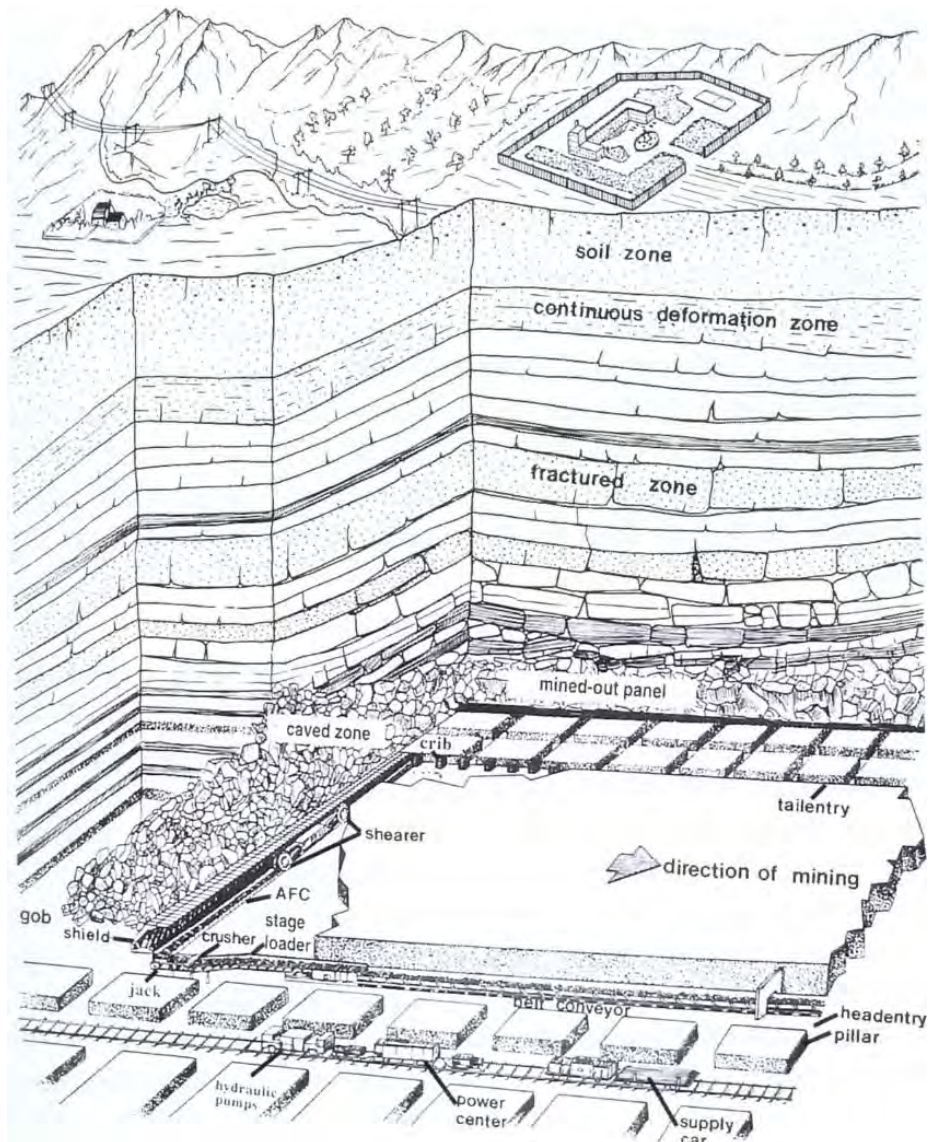

Fig 2.3.1 – Cut-away of Longwall Panel with equipment and overburden movement (Peng 2006)

### 2.3.1 DEVELOPMENT OF THE SUBSIDENCE TROUGH DURING MINING

A subsidence trough is a dish-shaped depression that develops above the mined-out area and progressively enlarges horizontally and vertically as coal support is systematically removed from beneath. A trough is generally characterized by stationary surface profiles in the longitudinal and transverse directions and by non-stationary

"dynamic" ground surface profile ("traveling wave") that accompanies the mine face in its passage from one end of the mine panel to the other (Figures 2.3 and 2.4).

- Longitudinal Profile.

The longitudinal profile is drawn along the panel centerline where the ground movements in the direction of mining are most pronounced (greatest subsidence, slope, strain, curvature). The segment of the longitudinal profile draping over the forward abutment -- that is, draping over the coal pillars beyond the face in the direction of mining- is termed the subsidence development curve and describes the vertical movement experienced by each point at ground surface as it is undermined. The subsidence development curve characteristically consists of three distinct segments (Figures 2.5, 2.6 and 2.7)

- Heave zone (A-B)
- Subsidence zone (B-C)
- Residual Subsidence zone (C-D)

- Transverse Profile

The transverse profile is drawn across the short dimension of the panel, perpendicular to the longitudinal axis, and is often located along the panel bisector. It can be positioned nearer to the end of the panel, but no nearer than twice the overburden thickness if the profile is to be representative of the maximum ground surface deformation in the transverse direction.

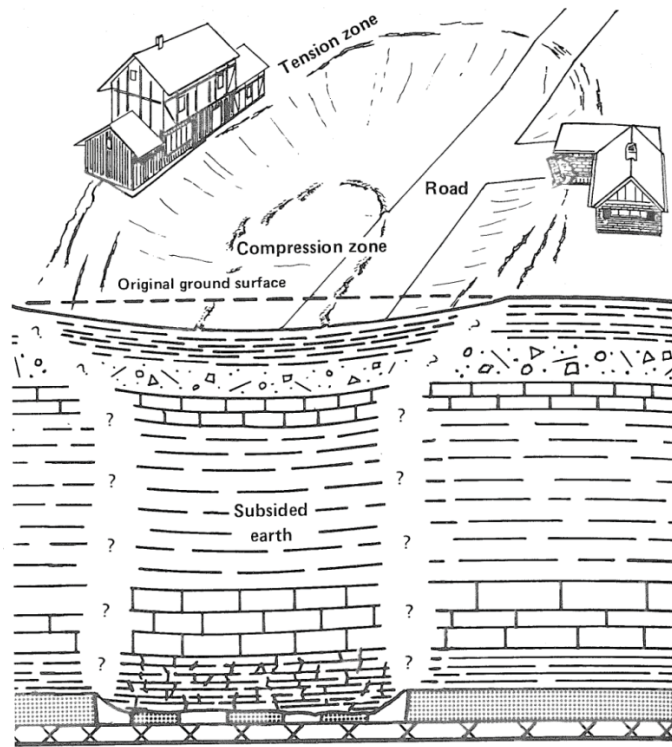

Fig 2.3.2 View of Typical Features of Trough Subsidence (Bauer & Hunt 1981)

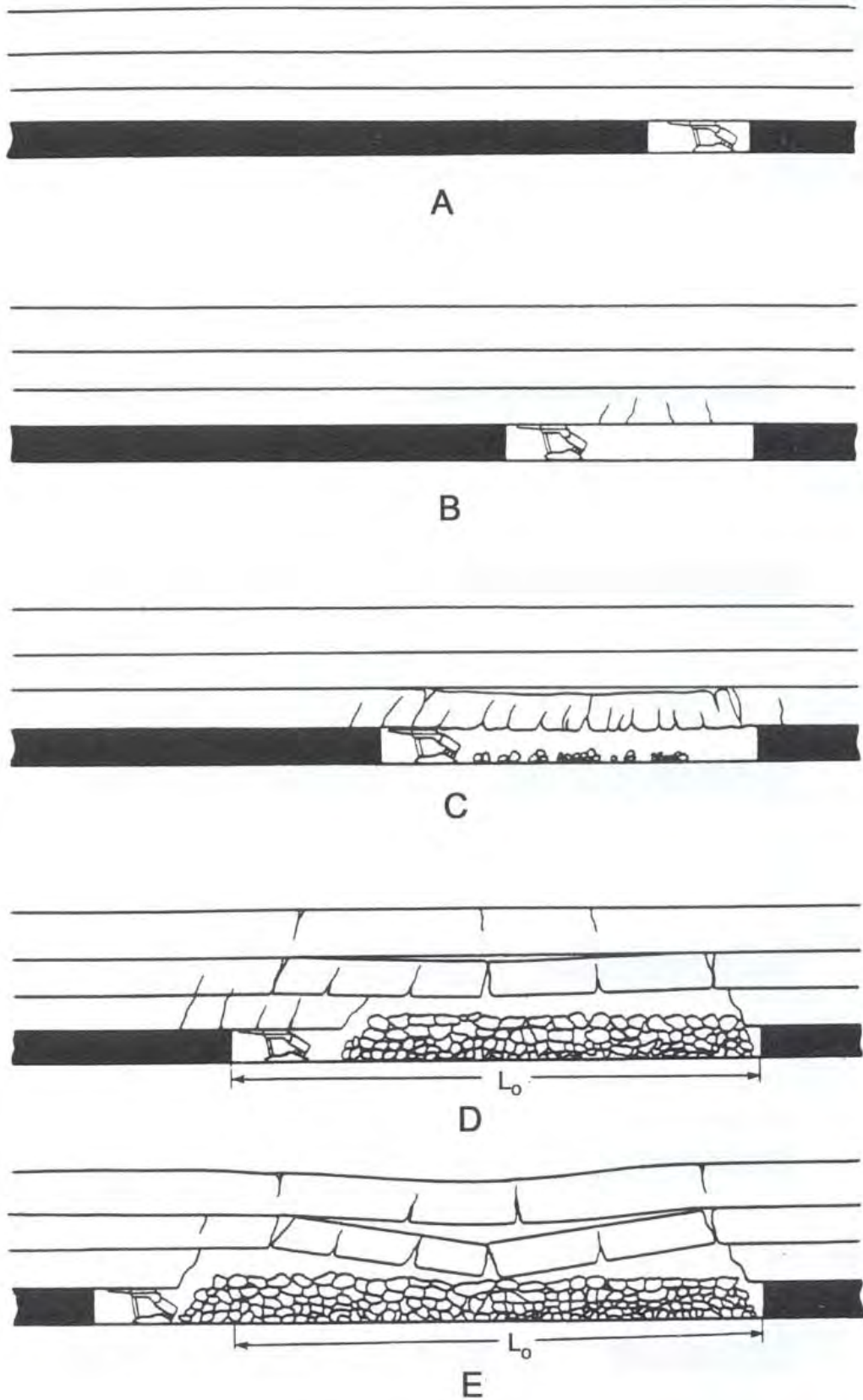

Fig 2.3.3 Idealized sequence of roof movements (Peng 2006)

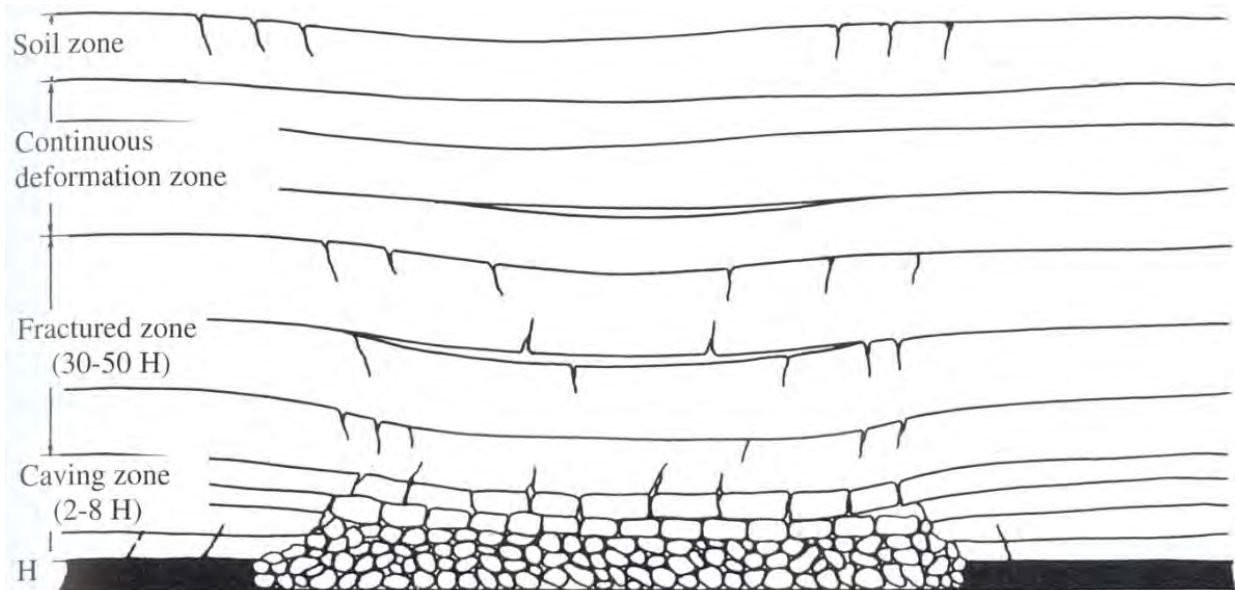

Fig 2.3.4 Immediate and main roofs (Peng 2006)

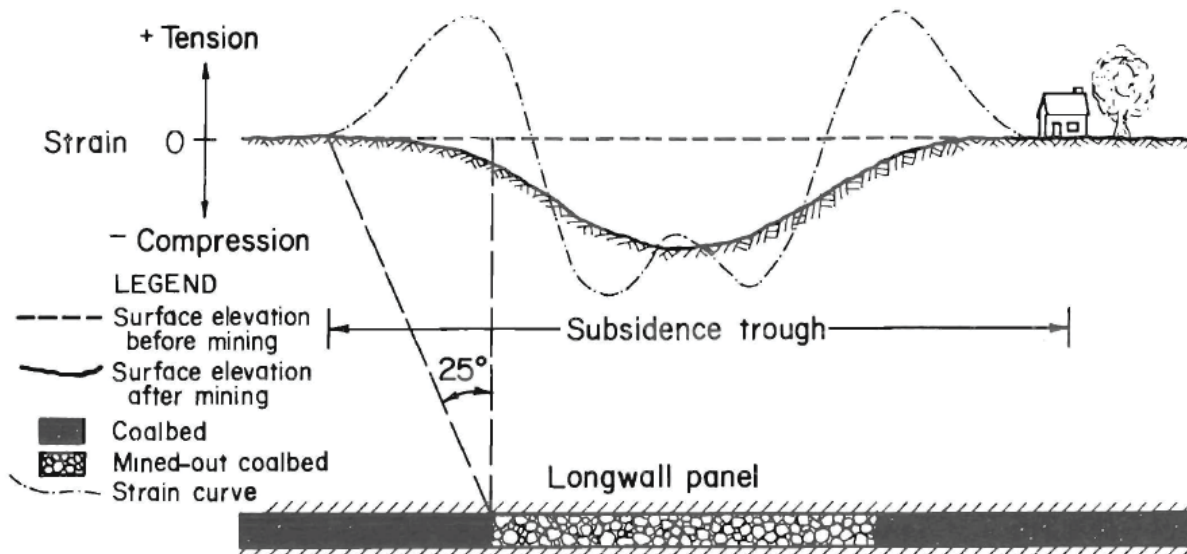

Fig 2.3.5 Subsidence trough and strain distribution (Ingram 1989)

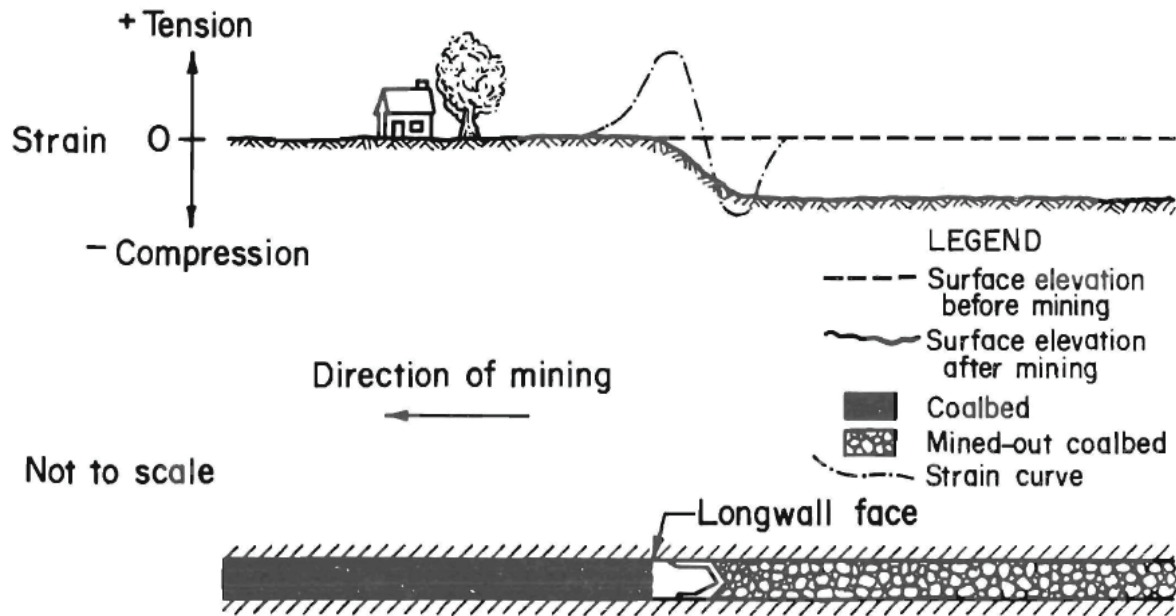

Fig 2.3.6 Strain along wave of subsidence during longwall development (Ingram 1989)

The shape of the subsidence development curve at any site is governed by the mechanical properties of the overburden and by the stiffness of the coal support at mine level.

The ground surface movements above the rear abutment, under ideal circumstances, are identical to those above the forward abutment. The ground surface heaves locally, if not generally. Long term creep and settlement may reduce the heave or eliminate it altogether.

## References, Chapter 2

Bauer, R.A. & Hunt, S.R. 1981. "Profile, Strain, and Time Characteristics of Subsidence from Coal Mining in Illinois." From *Proceedings of the Workshop on Surface Subsidence Due to Underground Mining*. Morgantown, WV.

Brown, B. H. G. & Brown, E. T. 1992. *Rock Mechanics for Underground Mining, 2<sup>nd</sup> Edition*. London: Chapman & Hall.

Crowell, D.L. 2010. *GeoFacts No. 12: Mine Subsidence*. Ohio Department of Natural Resources, Division of Geological Survey. [www.OhioGeology.com](http://www.OhioGeology.com)

Darling, P. (Ed.) 2011. *SME Mining Engineering Handbook, 3<sup>rd</sup> Edition*. Denver, CO. Society for Mining, Metallurgy, and Exploration, Inc.

Harrison, J.P. *Chapter 8.9 – Mine Subsidence*.

Hartman, H.L. 1992. *SME Mining Engineering Handbook, 2<sup>nd</sup> Edition*. Denver, CO. Society for Mining, Metallurgy, and Exploration, Inc.

Singh, M.M. *Chapter 10.6 – Mine Subsidence*.

Ingram, D.K. 1989. *Surface Fracture Development Over Longwall Panels in South-Central West Virginia*. U.S. Bureau of Mines, Report of Investigation 9424

National Coal Board. 1975. *Subsidence Engineers' Handbook*. London: National Coal Board, Mining Department.

OSM Technical Report 596. 1991. *GAI Consultants: Guidance Manual on Subsidence Control*. US Department of Commerce, Springfield, VA.

Peng, S. S. 2006. *Longwall Mining, 2<sup>nd</sup> Edition*. West Virginia: West Virginia University.

Pennsylvania Department of Environmental Protection Mine Subsidence Insurance Website  
<http://www.dep.state.pa.us/msihomeowners/>

You Tube videos from various sources, listed by subject:

Gob/Goaf animation: <http://youtu.be/AR2e77Rqlew>

Longwall Mining: <http://youtu.be/NsiGV7lmNXE>

Subsidence

BHP Billiton – Longwall Mining Subsidence Animation: <http://youtu.be/zvvyqJ2qfdw>



Fallen Futures part 1: [http://youtu.be/tqG\\_M73Zgv0](http://youtu.be/tqG_M73Zgv0)

Fallen Futures part 2: <http://youtu.be/4Q5WjJQj97M>

Introduction to Longwall Mining in Illinois: <http://youtu.be/9P9h1VrOs8I>

**CHAPTER 3:**  
**PRINCIPLE PARAMETERS**  
**OF**  
**SUBSIDENCE**

Kewal Kohli  
Stefanie Self

### 3.1 PRINCIPLE PARAMETERS THAT CHARACTERIZE SUBSIDENCE

The following parameters are commonly used to describe the geometry of a subsidence trough. All angles lie in a vertical plane normal to one of the edges of the mine panel (Figures 3.1.1, 3.1.2 and 3.1.3). Ideally, the angles are constant for a particular mine panel for a particular mine site.

- **Angle of Advance Influence ( $\alpha$ )**  
The angle with the vertical made by a straight line extending from the edge of the mined-out area to the nearest point of maximum tensile strain on the subsidence profile.
- **Angle of Break ( $\delta$ )**  
The angle with the vertical made by a straight line extending from the edge of the mined-out area to the nearest point of maximum tensile strain on the subsidence profile.
- **Angle of Complete Mining ( $\psi$ )**  
The angle with the vertical made by a straight line extending from the edge of the mined-out area to the nearest point of maximum tensile strain on the subsidence profile.
- **Angle of Critical Deformation or Angle of Damage ( $\zeta$ )**  
The angle with the vertical made by a straight line extending from the edge of the mined-out area to the point on the subsidence profile that could potentially damage a surface structure.
- **Angle of Draw ( $\beta$ )**  
The angle with the vertical made by a straight line extending from the edge of the mined-out area to the nearest point at ground exhibiting no subsidence. The angle delineates the boundary of the subsidence trough, excluding any heave zone. Typically  $20^\circ$ - $27^\circ$ .
- **Compressive Strain ( $\epsilon_c$ )**  
The amount of shortening per unit of length, and usually is represented by a negative value.
- **Curvature (k)**  
The difference in surface slope between two adjacent line sections divided by the average length of the two line sections on a subsidence profile.
- **Dimension B**  
The horizontal distance from the inflection point of the subsidence profile to the nearest point of maximum subsidence on the subsidence profile.
- **Displacement (U)**  
The horizontal component of the surface movement is called displacement.
- **Inflection Points**  
The points on the subsidence profile where the profile changes from convex to concave. At the inflection point, the subsidence is equal to half of the maximum possible subsidence at the center, the surface slope is maximum and the curvature is zero. The distance from the inflection point to the nearest edge of the opening is the "offset", d of the inflection point. This has been found to be located at the point where the Subsidence has reached half of its maximum value ( $S_{max}/2$ ).

- Maximum Subsidence ( $S_{max}$ )  
When the panel width exceeds a critical value, the maximum subsidence reaches its maximum possible value
- Mining Depth (h)  
Effective height of total overburden above coal seam being mined. Typically, this is the value from the top of the coal seam to the surface.
- Mining Height (m)  
Effective height of void left by mining (this will usually include the entire coal seam, plus some roof and/or floor material).
- Slope (i)  
Also called tilt, it is the difference in surface subsidence between the two end points of a line section divided by the horizontal distance between the two points on a subsidence profile.
- Strain ( $\epsilon$ )  
The change in length per unit length in a given direction. Ground strain represents the amount of extension or compression of the ground surface in the immediate vicinity of each ground surface point relative to an original.
- Subsidence (S)  
The vertical component of the surface movement is called subsidence.
- Subsidence Factor ( $a = S/m$ )  
The ratio of maximum subsidence to mining height. The subsidence factor is governed by the lithology of the overburden and the dimension of the mined-out area. The harder rocks in the overburden strata, the smaller will be the angle of draw and vice versa. In the US, its range is found to be 0.4 to 0.85.
- Tensile Strain ( $\epsilon_t$ )  
The amount of lengthening per unit length, and usually is represented by a positive value.

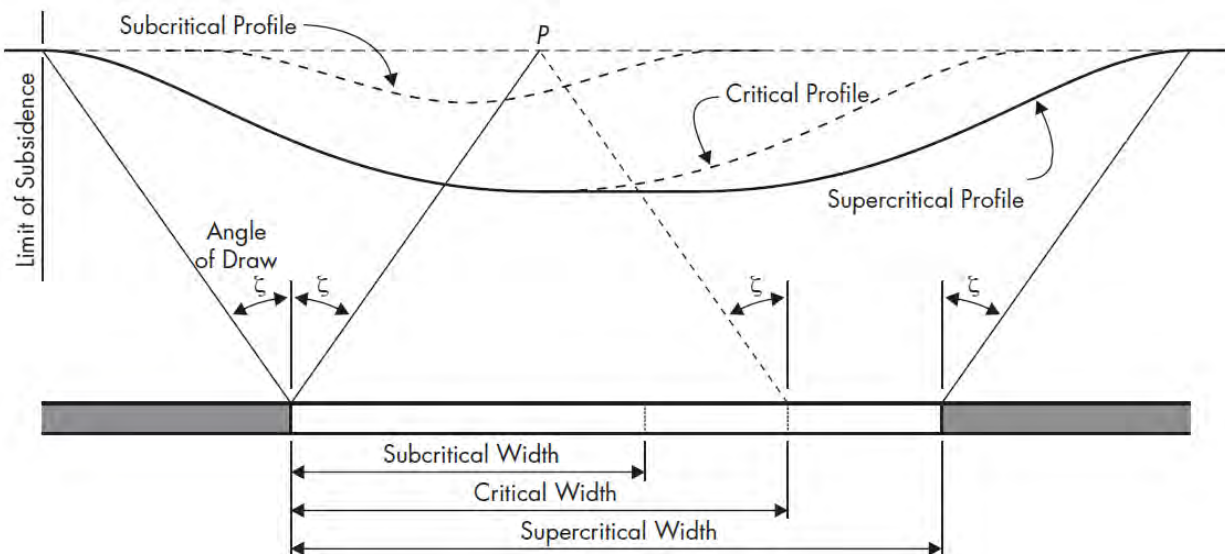

Fig 3.1.1 Continuous Subsidence Profiles above Laterally Extensive Extraction Zones (Darling 2011)

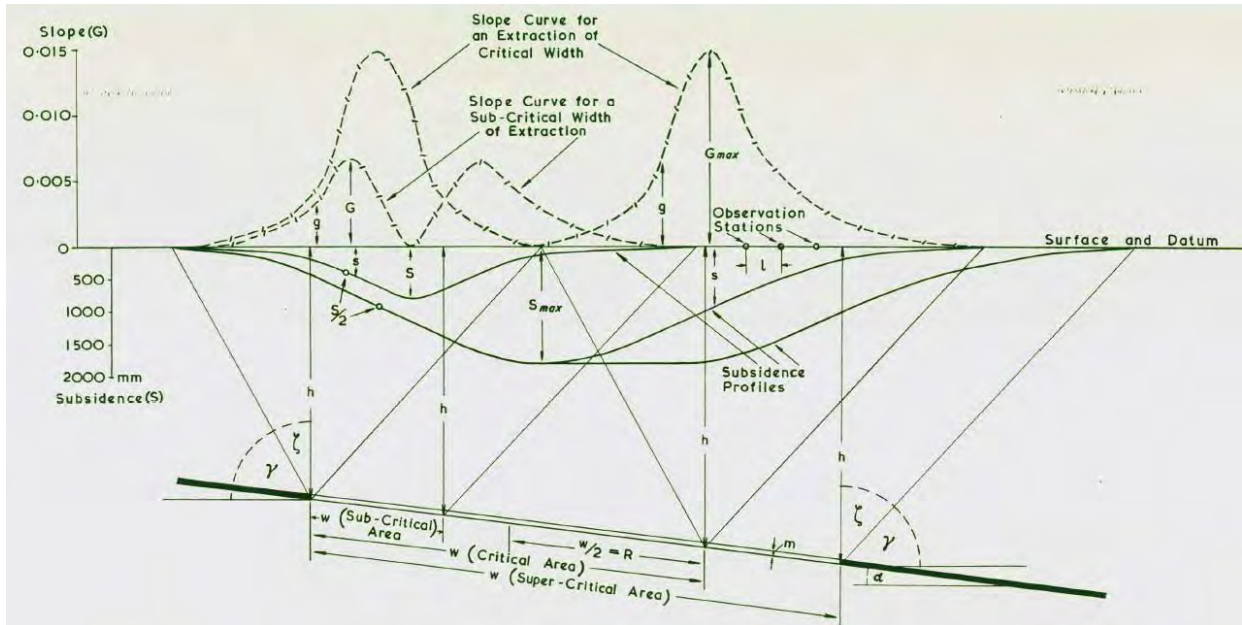

Fig 3.1.2 Typical section illustrating standard symbols for subsidence and slope (NCB 1975)

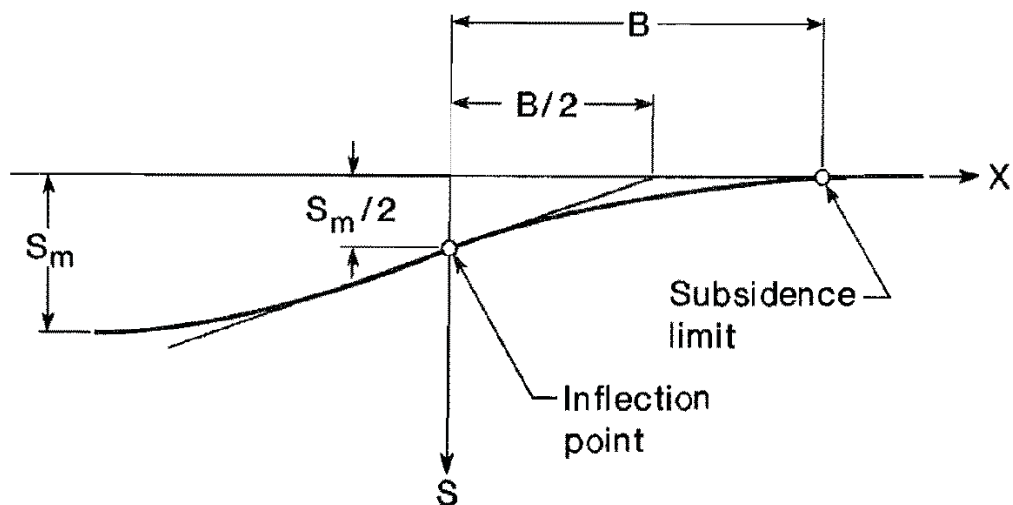

Fig 3.1.3 Maximum Subsidence and Inflection Point (Tandanand and Powell 1991)

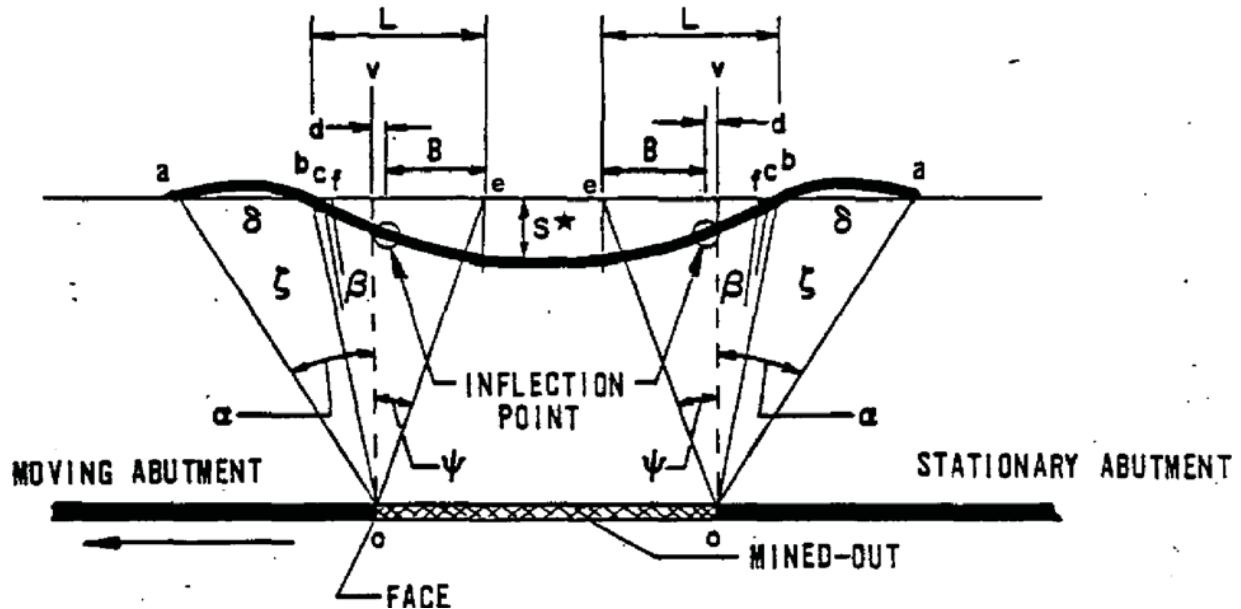

Fig 3.1.4 Principal Parameters that Characterize the Subsidence Trough (OSM 1991)

### 3.2 TYPES OF SUBSIDENCE TROUGHS

A subsidence trough is a dish-shaped depression that develops above the mined-out area and progressively enlarges horizontally and vertically as coal support is systematically removed from beneath. There are three types of subsidence troughs:

- Subcritical  
Lowering of the ground surface in a predictable manner -- predictable (within limits) as to areal extent, amount of subsidence and amount of ground surface distortion -- as a result of mining.
- Critical  
Lowering of the ground surface in a manner that cannot be predicted as to areal extent, amount of subsidence or amount of ground distortion, as a result of failure at mine level of the overburden support system (coal pillars/mine roof/mine floor) or as a result of the action of other unanticipated causes, such as the piping of unconsolidated sediments into the mine.
- Supercritical  
Lowering of the ground surface in a predictable manner - predictable (within limits) as to areal extent, amount of subsidence and amount of ground surface distortion - as a result of mining.

When the mined-out area is small (both width and length), the final (static) subsidence profile has a pointed bottom with the maximum value at the center of the profile. The maximum subsidence at the center increases with increasing size of the mined-out area. This is the subcritical trough. When both the width and length of the mined-out area have increased to a size  $1.2h$  ( $h$  being mining depth), subsidence reaches the maximum possible value at the center. This is the critical subsidence trough. Thereafter, though both the width and length of the mined-out area continue to increase, the maximum possible subsidence does not increase, but spreads laterally into an area. The subsidence trough has a flat bottom, and is known as the supercritical subsidence trough.



- Tensile Strain ( $\epsilon_t$ )

The amount of lengthening per unit length, represented by a positive value. Both compressive and tensile strains are found along the subsidence profile, as illustrated in Figures 3.1.2, 3.2, 3.3, 3.4.1, 3.4.2 and 3.4.3. Compressive (negative) strains are found near the center of the subsidence profile, with a transition to tensile (positive) strains towards the edge of the panel.

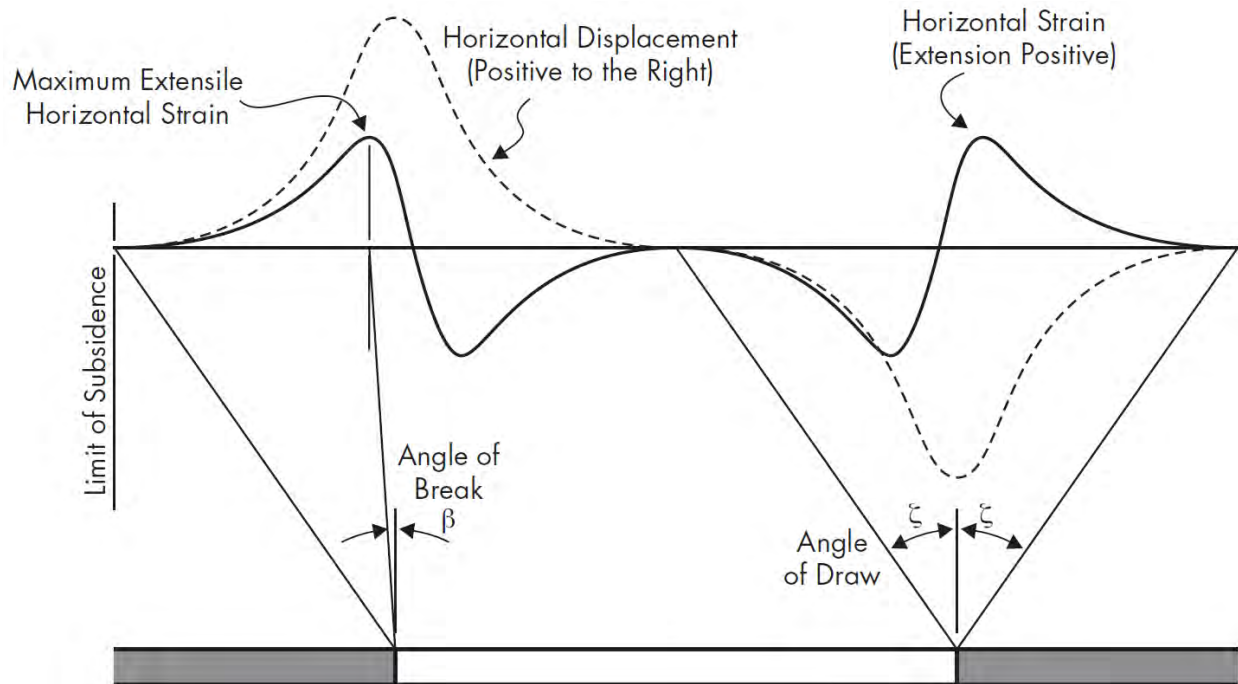

Fig 3.4 Illustration of a Subsidence Profile showing Strains and Angles (Darling 2011)

### 3.5 STATIC AND DYNAMIC STRAINS

Subsidence discussed above is the final profile that has developed long after mining has stopped. In a supercritical final subsidence trough, the central portion subsides uniformly. Thus any structure located there is not subjected to any permanent surface deformation (would drop vertically straight down, after subsidence is completed). However, during mining (while the face is moving), a structure is subjected to dynamic deformations associated with the dynamical subsidence trough (Figures 3.5.1, 3.5.2 and 3.5.3).

- Static Strain

Strain along the surface after final subsidence, after all movement has concluded.

- Dynamic Strain

Strain at the surface during subsidence development, as mining progresses toward, beneath and past a point on the surface.



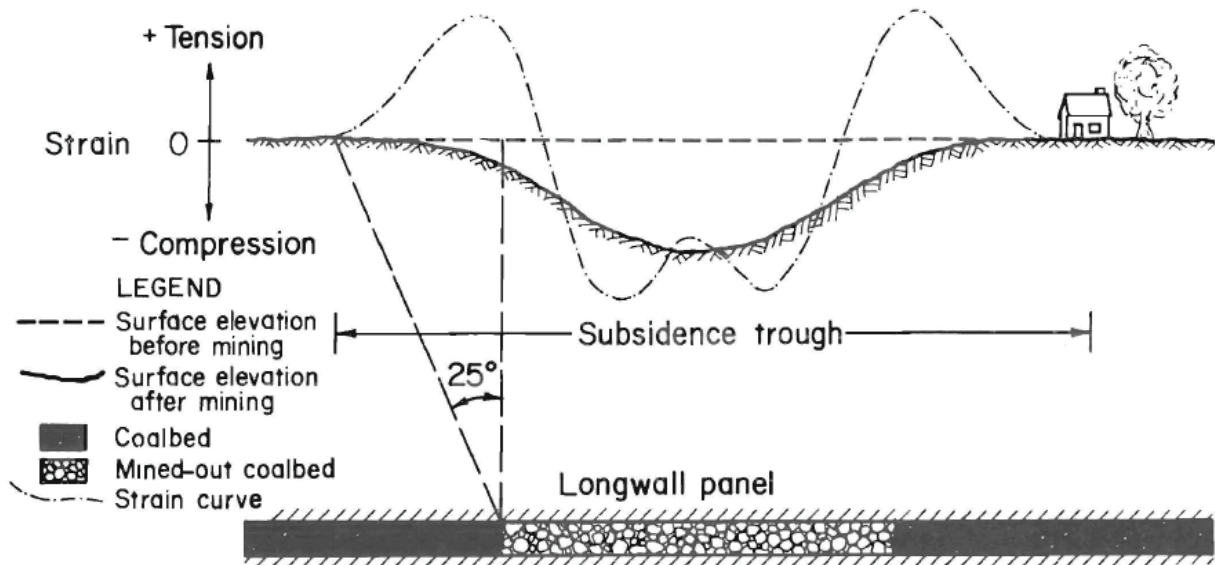

Fig 3.5.1 Subsidence trough and strain distribution (Ingram 1989)

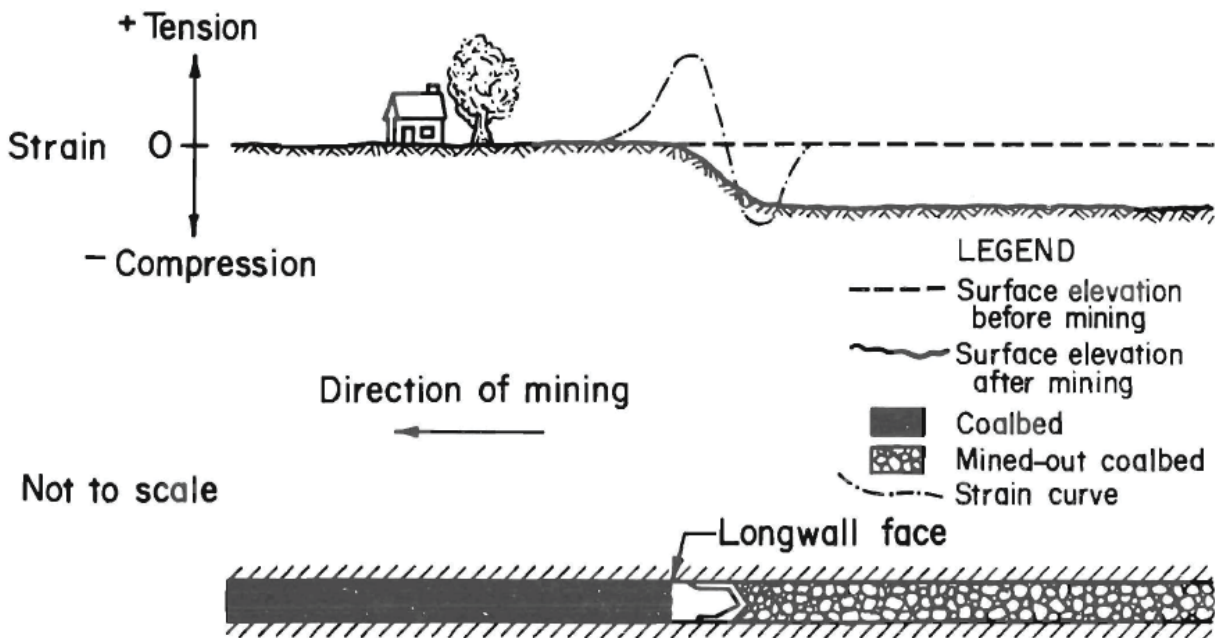

Fig 3.5.2 Strain along wave of subsidence during longwall development (Ingram 1989)

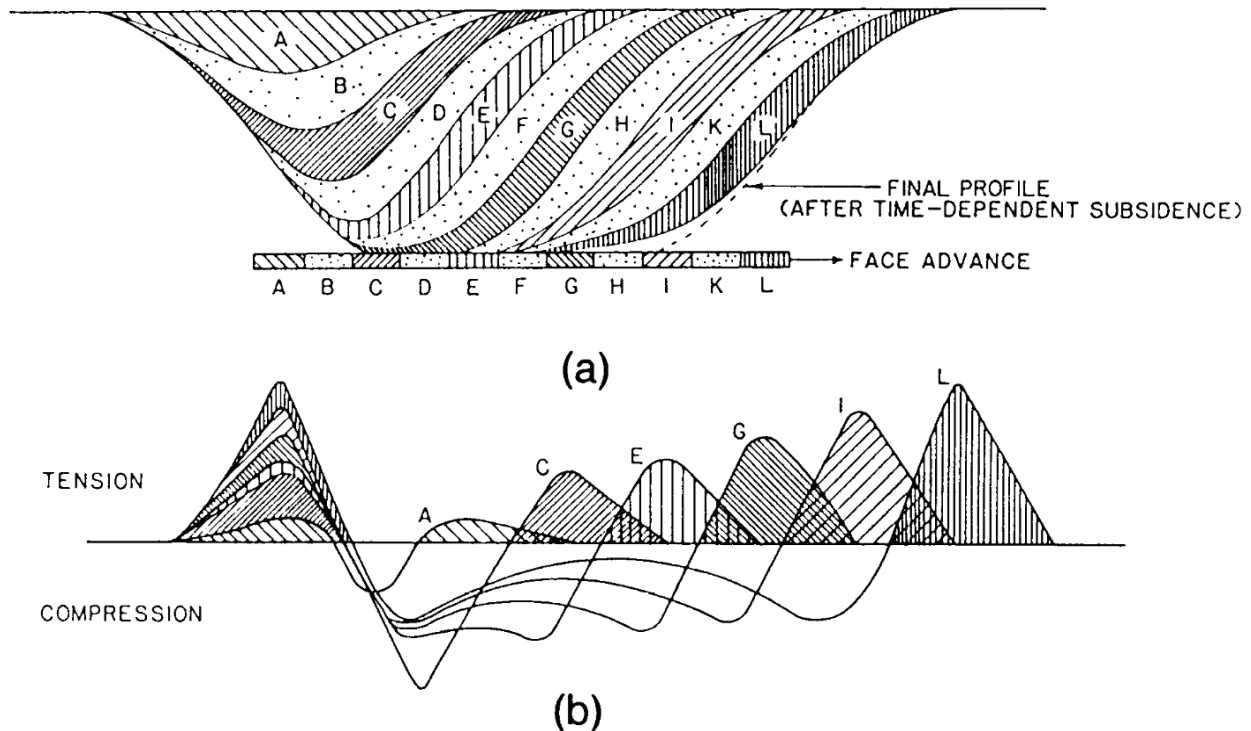

Fig 3.5.3 Development of Subsidence (Hartman 1992)

Consider a point on the ground surface. When the face has approached to within a given distance A of the point, the point begins to rise, or heave. The point continues to rise as the face draws nearer and reaches maximum of an inch or two when the face has approached to within a second given distance B. As the face draws closer, the point commences to move downward and achieves its pre-mining elevation once again when the face lies at a third distance C from the point. The point has moved below its initial elevation by the time the face is directly beneath the point and continues to move downward in the almost direct proportion to the distance the abutment has traveled beyond the point. The subsidence is nearly complete by the time the face has reached distance D from the point. Further movement is residual- time-dependent creep deformations that take place after mining is finished. Residual movements can be influenced by changing conditions, such as flooding of the mine, which may alter the properties of the rock materials years after the completion of mining.

The shape of the subsidence development curve at any site is governed by the mechanical properties of the overburden and by the stiffness of the coal support at mine level.

The ground surface movements above the rear abutment, under ideal circumstances, are identical to those above the forward abutment. The ground surface heaves locally, if not generally. Long term creep and settlement may reduce the heave or eliminate it altogether.

Vertical ground movements along a transverse section often take place (but may not always be noticed) when the face is as far distant as 0.5 times the thickness of the

overburden 'h' from the section line. These initial, relatively subtle movements are generally associated with the passage of the heave zone at the lead edge of the traveling wave. More commonly ground movements are not recognized until the face has approached to within  $0.25h$  of the section line, at which point the ground surface begins subsiding below the original ground surface elevation. Movements then continue systematically downward as the face passes beneath and then beyond the section line (Figure 2.8). The movements are generally complete when the face has passed  $1.5h$  to  $2h$  beyond the section line.

### 3.6 LONGITUDINAL AND TRANSVERSE PROFILE

A subsidence trough is generally characterized by stationary surface profiles in the longitudinal and transverse directions.

- Longitudinal Profile (Figure 3.3 )  
Drawn along the panel centerline where the ground movements in the direction of mining are most pronounced.
- Transverse Profile (Figure 3.3)  
Drawn across the short dimension of the panel, perpendicular to the longitudinal axis, and is often drawn along the panel bisector.

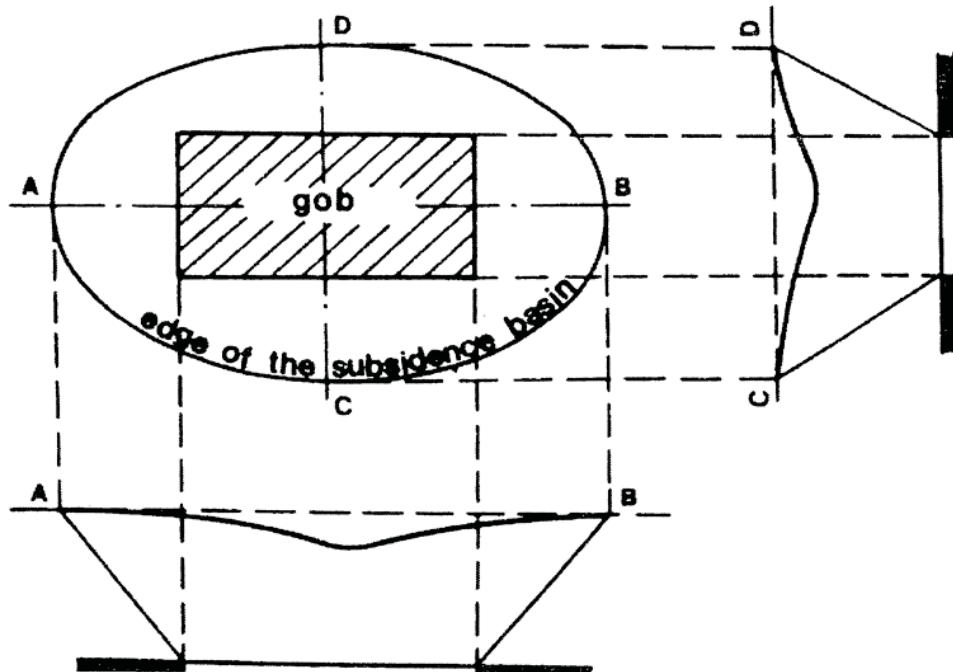

Fig 3.6 Longitudinal (A-B) and Transverse (C-D) Profiles of Subsidence Trough (Peng 2006)

### 3.7 SUBSIDENCE FACTOR AND PERCENT HARDROCK

Subsidence factor has been found to increase with the decrease in the percent of hardrock in the overburden.

### 3.8 SUBSIDENCE FACTOR AND WIDTH/DEPTH RATIO

The subsidence factor increases as the width and length of the panel increase relative to the mine depth. When the mine panel achieves or exceeds certain minimum (or critical) dimensions, a limiting maximum of  $a$  is attained. The subsidence factor under such conditions is governed primarily by the composition and properties of the overburden strata.

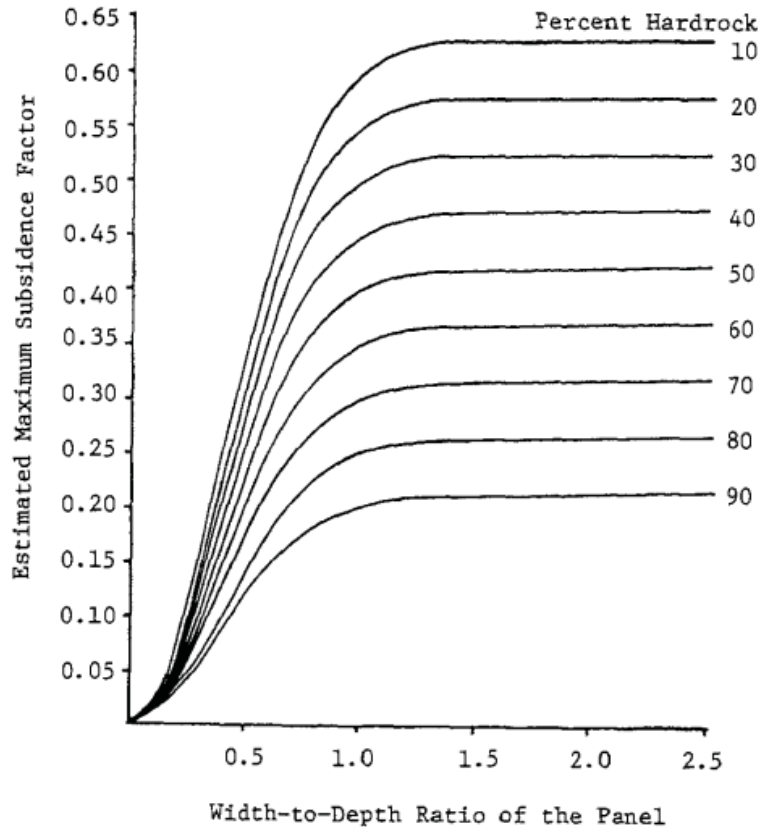

Fig 3.8 Relationship between Subsidence Factor, Width-to-Depth Ratio and Percent Hard Rock (Karmis et al 1983)

### 3.9 MULTIPLE PANEL EFFECTS

Longwall mining is always conducted on more than one panel running parallel to each other but separated by chain pillars. Surface subsidence caused by one panel tends to overlap those induced by the adjacent panels, depending on the angle of draw, seam depth, and chain pillar size.

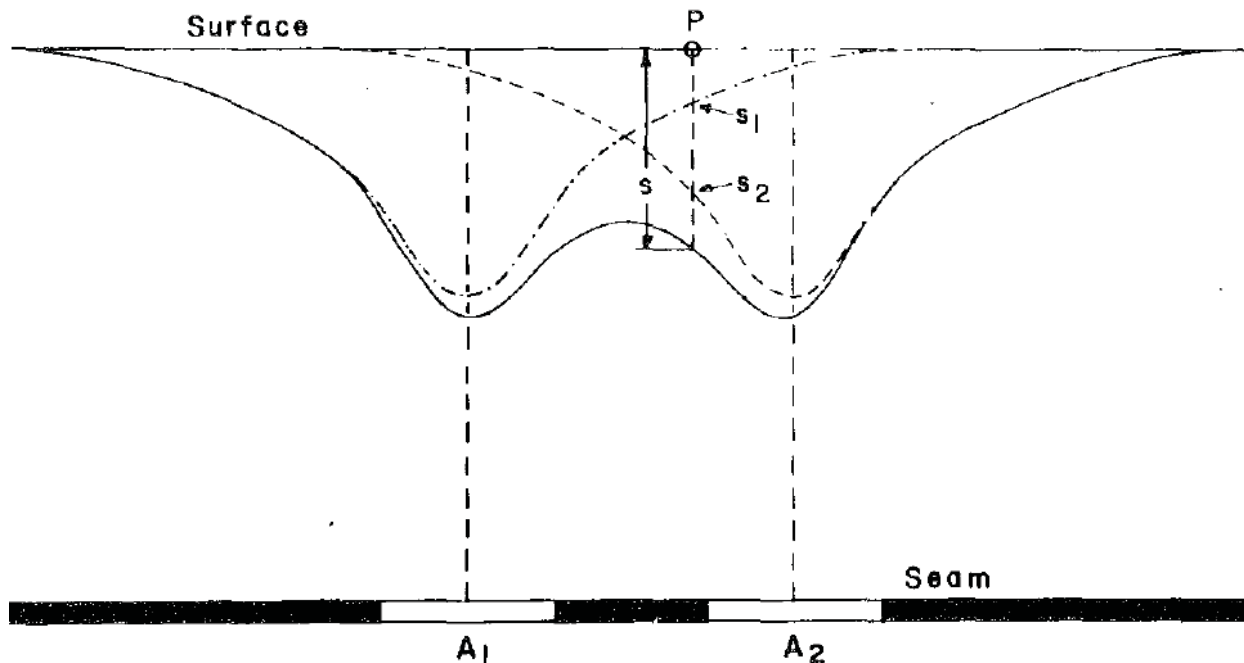

Fig 3.9 Superposition of Surface Subsidence Profiles (Brauner 1973)

## 3.10 SURFACE TOPOGRAPHY

### 3.10.1 Sloping Terrain over a horizontal coal seam

Mining subsidence effects on sloping ground surfaces can result in extensive zones of tensile strain developing on the up-slope side of the mined-out areas, in addition to localized steepening of the ground slope. There is an accompanying down-slope movement trend which can be of special significance where slopes exhibit natural creep. The increased zone of tensile strain can be of importance in encouraging the opening of natural and induced fissures, cracks and other weakness features which can lead to aggravation of stability by entry of water.

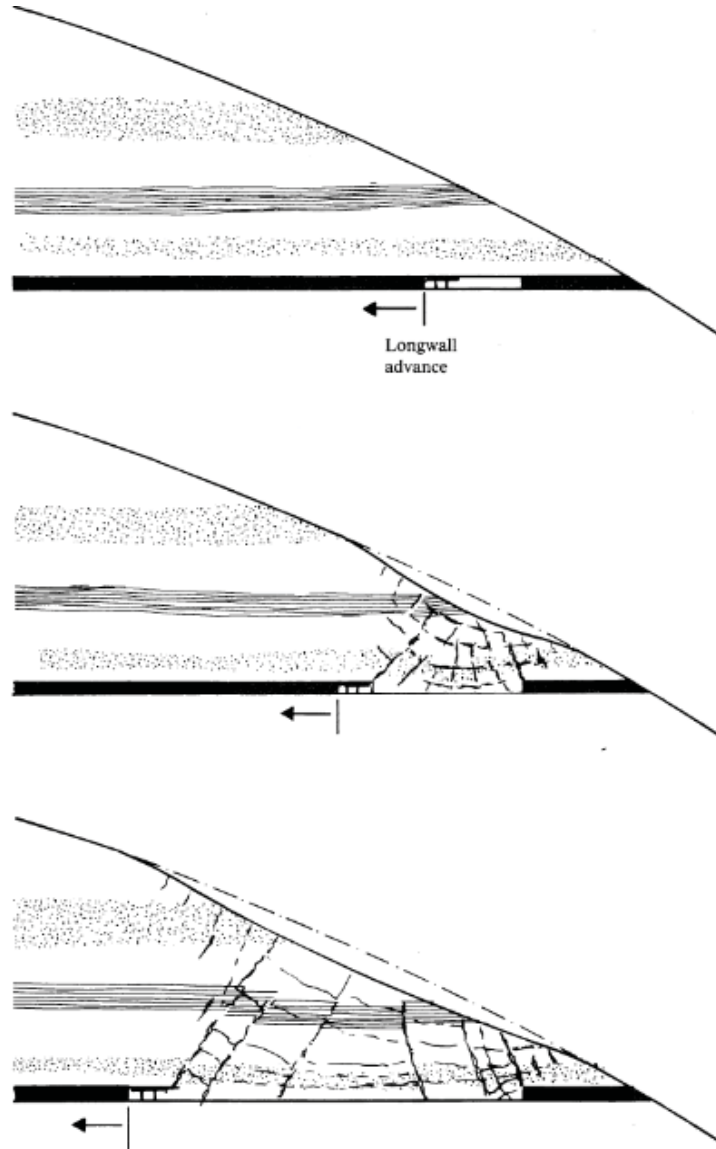

Fig 3.10.1 Initiation and trough development as longwall depth of cover increases (Whittaker and Reddish 1989)

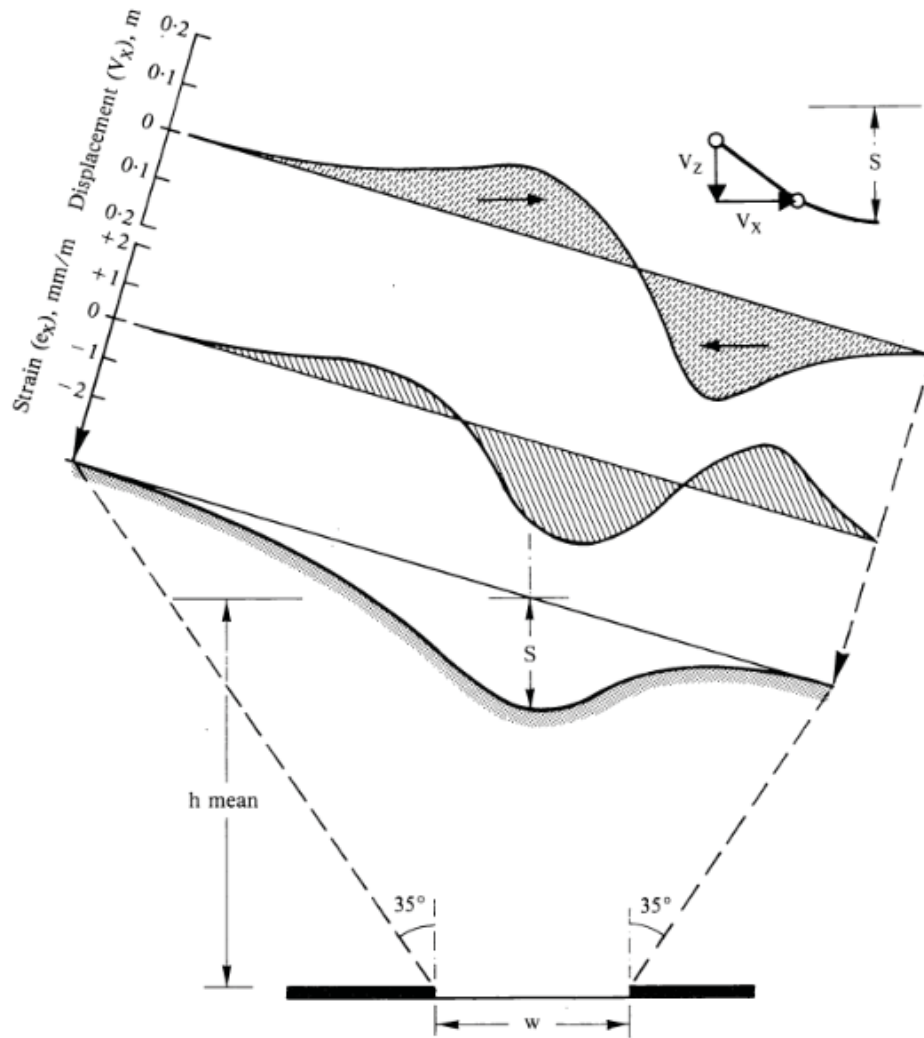

Fig 3.10.2 Subsidence, Strain and Displacement Over a Surface Ground Slope of 15° (Whittaker and Reddish 1989)

Sloping ground tends to emphasize downward movements because of gravity. Tensile strains may become more marked on hilltops and decrease in valleys. Surface effects are influenced accordingly.

### Summary of potential ground slope instability arising from mining subsidence (Whittaker and Reddish, 1989)

When considering potential ground slope instability arising from the effects of mining subsidence, there are a number of factors which should be examined:

- 1) The significantly broadened zone on the up-slope side encourages the opening of existing weakness planes favourably oriented relative to the direction of longwall extraction. The opening of existing weakness planes such as fissures, joints and fault planes can lead to decreasing the structural integrity of the slope.
- 2) A slope weakened by tensile strain effects in the form of crack development, becomes vulnerable to the access of water and possibly resulting decrease in

natural stability.

- 3) Steep faces and exposed rock scars can be subjected to increased toppling effects. Small changes in tilt can have an appreciable influence on the natural stability of cliffs and overhangs.
- 4) There is a resultant movement down the slope which can accentuate any natural creep taking place.
- 5) In mountainous terrain, major rock structures can experience stability changes. Narrow canyons and scree areas may prove to be vulnerable to changes in tilt.

### 3.10.2 Level Terrain over an inclined coal seam

When the coal seam being mined is inclined, an asymmetric subsidence trough is formed that is skewed toward the rise; that is, the limit angle is greater on the dip side of the workings. The strains are also smaller toward the dip direction. See Figures 3.10.3 and 3.10.4.

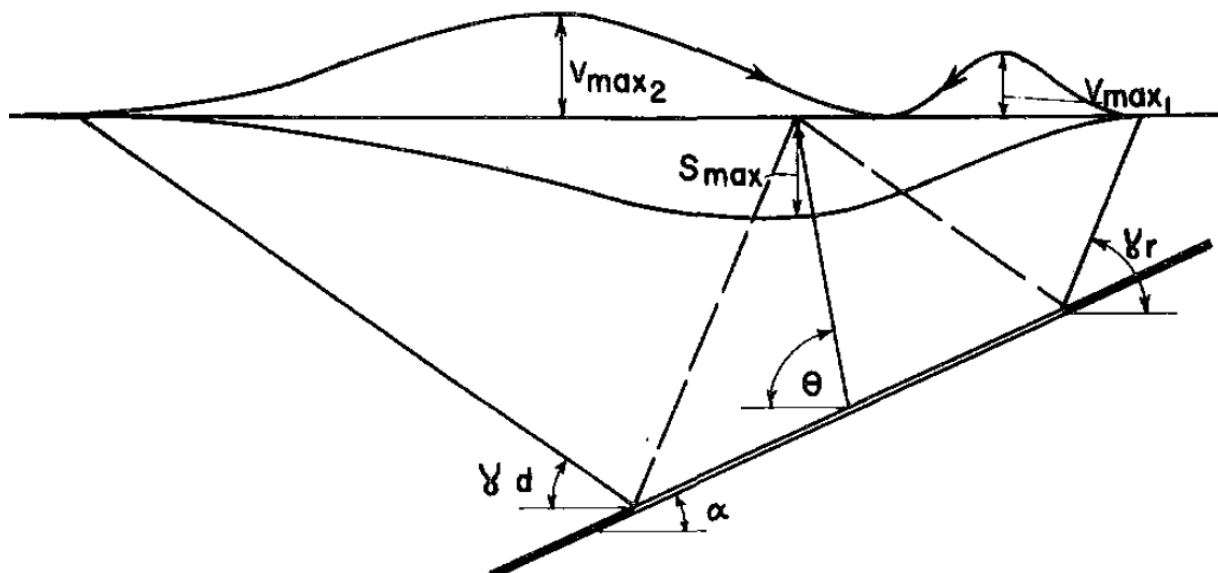

Fig 3.10.3 Subsidence Displacements Over an Inclined Seam (Brauner 1973)



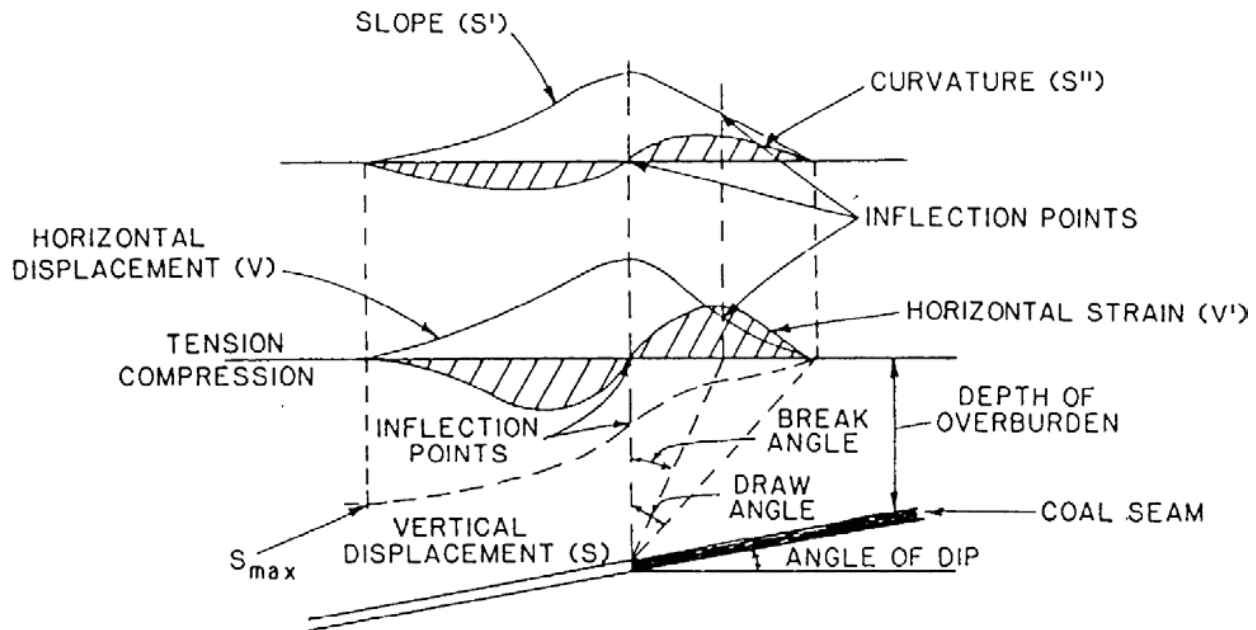

Fig 3.10.4 Schematic of ground movements caused by subsidence (Hartman 1992)

### 3.11 TIME EFFECTS

The amount of subsidence observed is a function of time. In room and pillar operations, no surface effects may be noted for some time after the mining is complete until the pillars deteriorate or punch into the floor. In longwall mines, the surface starts sagging almost immediately after the face passes below an area. However, the occurrence of massive beds in the overburden could delay this. With longwalls, surface movements are complete within a few years, but when pillars are left intact for support, this may take decades. Room and pillar mining with removal of pillars may produce surface effects similar to longwall mining, with the degree of similarity dependent upon the amount of coal left as fenders or stumps.

The duration of subsidence resulting from mining is composed of two distinct phases: (1) active and (2) residual. Active subsidence refers to all movements occurring simultaneously with the mining operations, while residual subsidence is that part of the surface deformation that occurs following the cessation of mining (or in the case of longwall mining, after an underground excavation has reached its critical width). The duration of residual subsidence is of particular importance from the standpoint of structural damage at the surface as well as from a legal perspective. The latter involves evaluating the extent of liability of underground mine operators for postmining subsidence

## References, Chapter 3

Brauner, G. 1973. *Bureau of Mines Information Circular 8571: Subsidence Due to Underground Mining Part 1: Theory and Practices in Predicting Surface Deformation.*

Brown, B. H. G. & Brown, E. T. 1992. *Rock Mechanics for Underground Mining, 2<sup>nd</sup> Edition.* London: Chapman & Hall.

Crowell, D.L. 2010. *GeoFacts No. 12: Mine Subsidence.* Ohio Department of Natural Resources, Division of Geological Survey. [www.OhioGeology.com](http://www.OhioGeology.com)

Darling, P. (Ed.) 2011. *SME Mining Engineering Handbook, 3<sup>rd</sup> Edition.* Denver, CO. Society for Mining, Metallurgy, and Exploration, Inc.

Harrison, J.P. *Chapter 8.9 – Mine Subsidence.*

Hartman, H.L. 1992. *SME Mining Engineering Handbook, 2<sup>nd</sup> Edition.* Denver, CO. Society for Mining, Metallurgy, and Exploration, Inc.

Singh, M.M. *Chapter 10.6 – Mine Subsidence.*

Ingram, D.K. 1989. *Surface Fracture Development Over Longwall Panels in South-Central West Virginia.* U.S. Bureau of Mines, Report of Investigation 9424

Karmis, M., T. Triplett, C. Haycocks and G. Goodman. 1983. *Mining Subsidence and Its Predictions in the Appalachian Coalfield.* Proceedings of the 24th U.S. Symposium on Rock Mechanics. College Station, TX. June, pp. 665-675.

National Coal Board. 1975. *Subsidence Engineers' Handbook.* London: National Coal Board, Mining Department.

OSM Technical Report 596. 1991. *GAI Consultants: Guidance Manual on Subsidence Control.* US Department of Commerce, Springfield, VA.

Peng, S. S. 2006. *Longwall Mining, 2<sup>nd</sup> Edition.* West Virginia: West Virginia University.

Pennsylvania Department of Environmental Protection Mine Subsidence Insurance Website  
<http://www.dep.state.pa.us/msihomeowners/>

Tandanand, S and Powell, L.R. 1991 - *Report of Investigations 9358: Determining Horizontal Displacement and Strains Due to Subsidence.* US Department of the Interior, Bureau of Mines.

Whittaker, B.N. and Reddish, D.J. 1989. *Subsidence: Occurrence, Prediction and Control.* Department of Mining Engineering, The University of Nottingham, United Kingdom.

**CHAPTER 4:**

**STRUCTURAL DAMAGE**

**PREDICTION**

Mark Frederick  
Kewal Kohli  
Stefanie Self

## OVERVIEW OF STRUCTURAL DAMAGE AND CAUSES

Damage to surface structures can be caused by many different events, including ground movements caused by coal mining. Individual components of ground movements are commonly expressed in terms of certain engineering parameters such as: (1) differential settlement; (2) horizontal strains; and (3) curvature, which were all discussed in earlier chapters. However, many of the damages that occur in buildings can be caused by a wide range of factors (not just mining-caused ground movements). Therefore, in this chapter we will discuss various types of damages, and what causes can be linked to each type.

### 1.1 Types of Surface Structural Damages

The main causes of surface damage arising from mining subsidence have been defined as subsidence, tilt, tensile strain and compressive strain. It is difficult to quantify in specific terms how surface structures will respond to the effects of undermining (Whittaker and Reddish 1989).

#### A. Structural Damage Due to Discontinuous Surface Movements

1. Fissures or Cracks: Open cracks can cause dislocation of surface structure if the gaps are large which the structure cannot resist but fail. Minor cracks affect appearance and not the structural integrity.
2. Steps: when a structure is located on a step, some portion of the structure loose support and become overhung.
3. Cave-in Pits: If the cave-in pit is larger than the structure, the structure will drop into the pit and become unstable.
4. Bumps (compressive ridges): Bumps will disrupt roadways or house floor lift is located under supporting members of the structure, it may cause damage.

#### B. Structural Damage Due to Continuous Movements

1. Subsidence: Pure subsidence does not cause structural damage. However, if this happens in a low lying area, it can cause flooding.
2. Slope (tilt): Ground slope will induce tilting of the structure. Tall buildings will be severely affected. It can also affect the buried gas, oil, and water lines. Highways and railroads can also be affected.
3. Curvature: There are positive (convex) and negative (concave) curvature. The structure will experience different type of damage depending upon the location of the structure with respect to movement.
4. Horizontal Strain and Displacement : Uniform displacement like uniform subsidence, will not cause any damage. Non-uniform displacement however induces strain. There are positive (tensile strain- Figure 5.3) and negative (compressive strains- Figure 5.4). Horizontal strains and the curvature are the major factors causing structural damage, especially tensile strain, because the structural elements are much weaker in tension than compression:
5. Twisting (Figure 5.5): Twisting occurs when the face is moving obliquely to the long dimension of the structure.
6. Shearing (Figure 5.6): When the ground is subject to large shear strain or strains in the diagonal direction of the structure, the foundation slabs and possibly superstructures may be damaged.

## Types and Causes of Plaster and Masonry Cracks

One of the principal causes of the cracking of plaster in residential construction is the shrinkage and expansion of lumber as the atmospheric humidity changes over a period of time. This movement is very heavy across the grain of the lumber and rigid materials (such as plaster) that are attached to the lumber will crack when sufficient movement occurs.

The United States Department of the Interior, Bureau of Mines, published a list of **40 causes of Cracks in Walls and Ceilings** (BoM Bulletin 442, 1942):

1. Building a house on a fill
2. Failure to make the footings wide enough
3. Failure to carry the footings below the frost line
4. Width of footings not made proportional to the loads they carry
5. The posts in the basement not provided with separate footings
6. Failure to provide a base raised above the basement floor line for the setting of wooden posts
7. Not enough cement used in the concrete
8. Dirty sand or gravel used in the concrete
9. Failure to protect beams and sills from rotting through dampness
10. Setting floor joists one end on masonry and the other on wood
11. Wooden beams used to support masonry over openings
12. Mortar, plaster or concrete work allowed to freeze before settings
13. Braces omitted in wooden walls
14. Sheathing omitted in wooden walls (except in "back-plastered" construction)
15. Drainage water from roof not carried away from the foundations
16. Floor joists too light
17. Floor joists not bridged
18. Supporting posts too small
19. Cross beams too light
20. Subflooring omitted
21. Wooden walls not framed so as to equalize shrinkage
22. Poor materials used in plaster
23. Plaster applied too thin
24. Lath placed too close together
25. Lath run behind studs at corners
26. Metal reinforcement omitted in plaster at corners
27. Metal reinforcement omitted where wooden walls join masonry
28. Metal lath omitted on wide expanses of ceiling
29. Plaster applied directly on masonry at chimney stack
30. Plaster applied on lath that are too dry
31. Too much cement in the stucco
32. Stucco not kept wet until set
33. Subsoil drainage not carried away from walls
34. First coat of plaster not properly keyed to backing
35. Wood beams spanned too long between posts
36. Failure to use double joists under unsupported partitions

37. Floor joists placed too far apart
38. Too few nails used
39. Rafters too light or too far apart
40. Failure to erect trusses over wide wooden openings

From this list, we can see that a large variety of damage that can be observed in buildings can be caused by poor construction methods, as well as external factors such as subsidence. The following is the type of damage that we might come across during an investigation, with some possible causes of each type of damage:

### *1.1.1 Water Damage*

Water is one of the principle causes of damage to buildings. Figure 1 illustrates a number of ways in which this can occur (PCS 1990).

1. Leakage through the metal or membrane material forming a valley or low section of a roof
2. Leakage over such valleys or low sections caused by the obstruction of the valley or stoppage of the outlet draining the low section
3. Leakage in a chimney saddle
4. Leakage because of the lack of a chimney saddle
5. Leakage in chimney flashing. This is very prevalent due to the fact that a wood frame building shrinks and the chimney does not.
6. Rain falling into the flues of a chimney may leak through the walls of the chimney, especially if there are no flue linings.
7. The cap of a chimney may be broken and allow water to penetrate.
8. (Missing from illustration)
9. Leakage at poorly installed gutter hangers
10. Roof rainwater overshooting low gutter
11. Gutter spilling, too small or hung out of level
12. Roof rainwater falling behind gutter
13. Sill or sub-sill leak
14. Wall leak, aggravated by rusted-out downspouts
15. Leaks in brick veneer which run down outside of sheathing and run in over top of foundation
16. Poor grading which leads surface water toward house
17. Leaks under basement windows
18. Leaks under basement window sills
19. Leaks between chimney and main wall of building, especially in frame structures
20. Leaks directly through foundation walls
21. Hydrostatic pressure forcing water up through joints of basement floor
22. Water from overflowing plumbing leaking through floor
23. Leaks in water or drain lines
24. Shower water finding its way through partition
25. Condensation from cold water lines

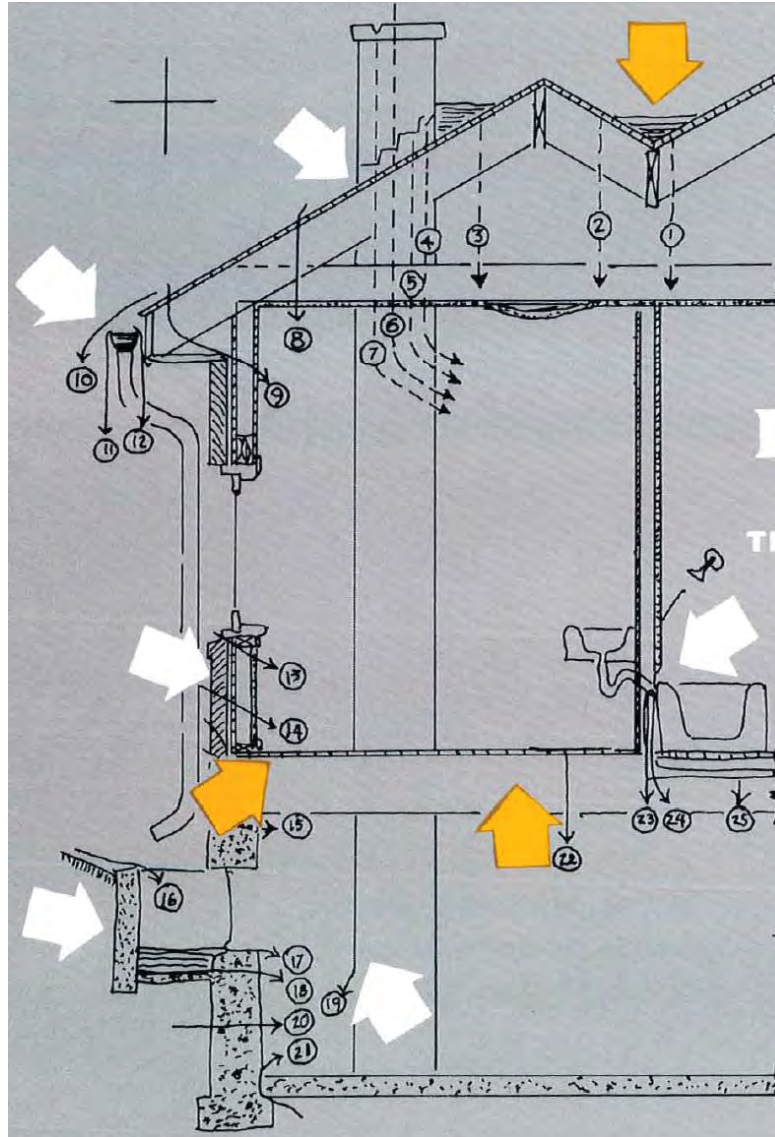

Figure 1 – Water Damage illustration from PCS 1990.

### ***1.1.2 Cracks Caused by the Failure of Shallow Foundations***

Buildings without basements may not have deep foundations. Such foundations can be affected by extremes of cold and heat. Two illustrations as to how this can occur are shown in Figure 2 (PCS 1990).

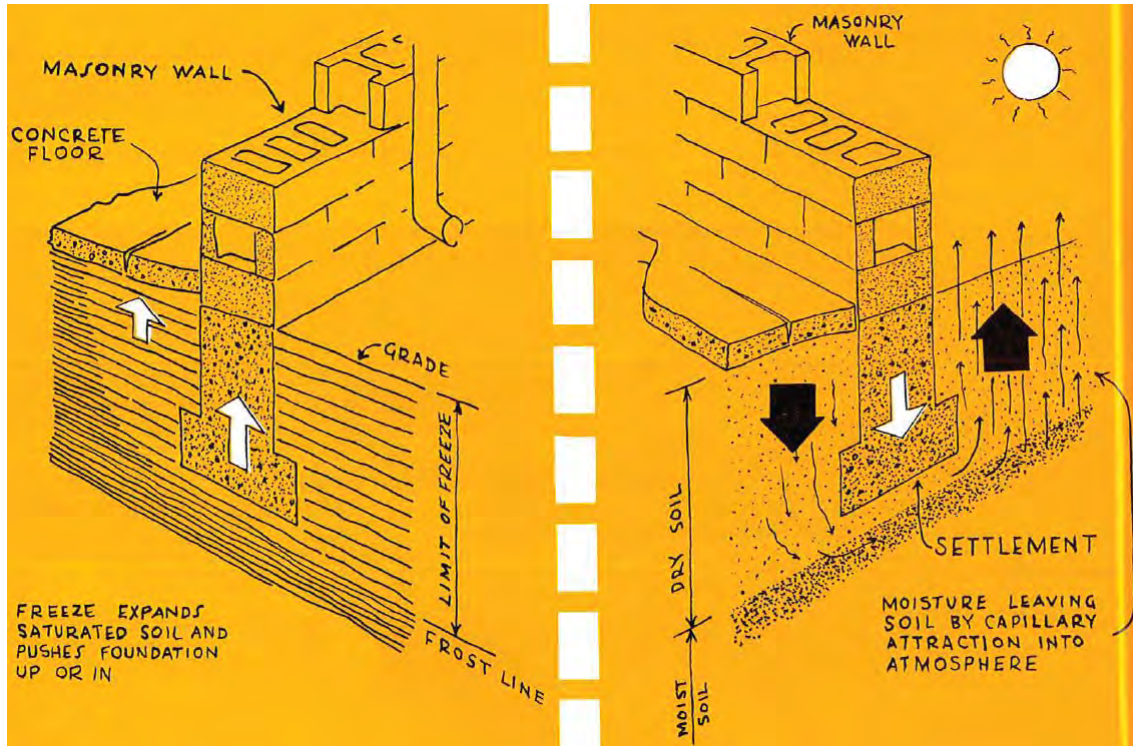

Figure 2 – Cracks Caused by Shallow Foundation Failure illustration from PCS 1990.

- **Buildings may not have foundations that extend below the frost line**
  - Winter freezes can extend down into the earth below the bottom of the footings
  - Causes earth to expand and creates pressure inward and upward on the foundation
  - When repeated, foundation can fail and cracks result in foundation and above
- **Water may be allowed to accumulate near foundations**
  - Downspouts may discharge near foundation
  - Drainage may not be adequately established to drain water from foundation
- **Weather conditions may promote moisture movement**
  - Extreme heat and drought may pull moisture from the soil
  - May cause shrinkage of soil, creating differential settlement of foundation

### ***1.1.3 Cracks Caused by Foundation Failures***

Buildings with basements have deep foundations, which are subject to vertical and lateral pressure from the exterior soil. The amount of this force depends on the weight of the soil, its natural vertical stability, and the height of the retaining section of the wall. This force is rarely constant since the weight and stability depends on the moisture content of the soil. Two illustrations as to how this can occur are shown in Figure 3 (PCS 1990).



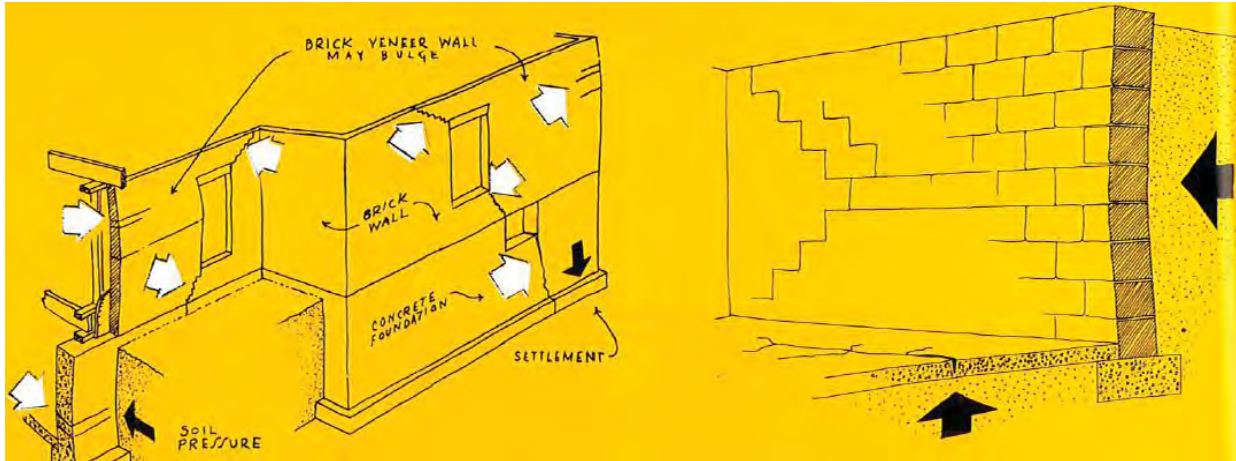

Figure 3 – Typical Foundation of Dwelling having a Basement illustration from PCS 1990.

- **Foundation may not be designed with sufficient strength to withstand the lateral pressures of the soil on the exterior (Left portion of Figure 3)**
  - When saturated, the exterior soil pressure on a six foot wall can increase from an average of 530 to 1350 pounds per square foot (psf).
  - Frost action can cause saturated earth to expand to 1/7 greater than its original size, and will exert tremendous pressure in all directions on the foundation.
- **Hydrostatic Pressure can affect concrete floors (Right portion of Figure 3)**
  - Water pressure often becomes great enough to push up on basement floors. Slight pressure often causes leaks where the floor joins the foundation.
  - Frost action can cause saturated earth to expand to 1/7 greater than its original size, and will exert tremendous pressure in all directions on the foundation.

If the foundation has been placed over poor soil, over filled ground, on the side of the hill, etc., simple settlement may occur. In time, cracks from the footings to the cornice will result, and since windows and doors weaken the wall, the cracks will most often run from one to the other of these openings.

This type of settlement is quite prevalent in buildings placed on hillsides. One end of the building will be deep into the slope (underground), and the opposite end will be out of the slope, and the foundations will be much nearer the surface. The end in the hillside will be more protected from the extremes of temperature than the side exposed.

#### ***1.1.4 Other Construction-based Sources of Damage***

Review literature as referenced for other sources of structural damage that are not due to Mine Subsidence. Always check to ensure that poor construction or cheap materials are not the root cause of damage claims!

## 1.2 Causes of Subsidence Structural Surface Damage

There are three main causes of damage to structures caused by mine subsidence. We will discuss each of these in turn, showing examples of each.

### 1.2.1 Differential Settlement

Where part of the structure settles more than another:

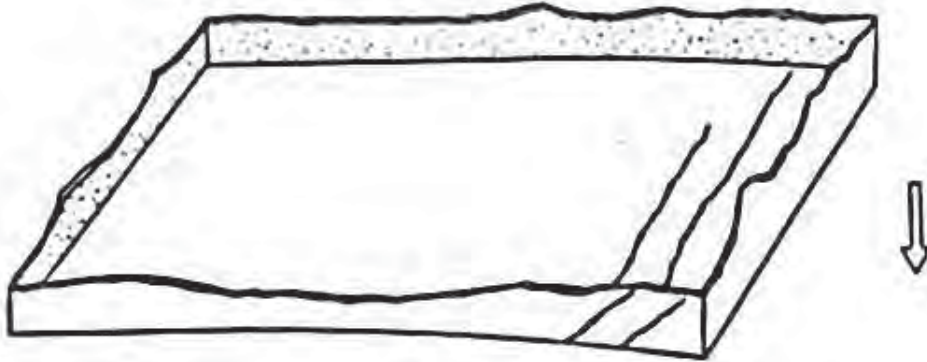

a) Cracks in basement floor (on the side of greater settlement)

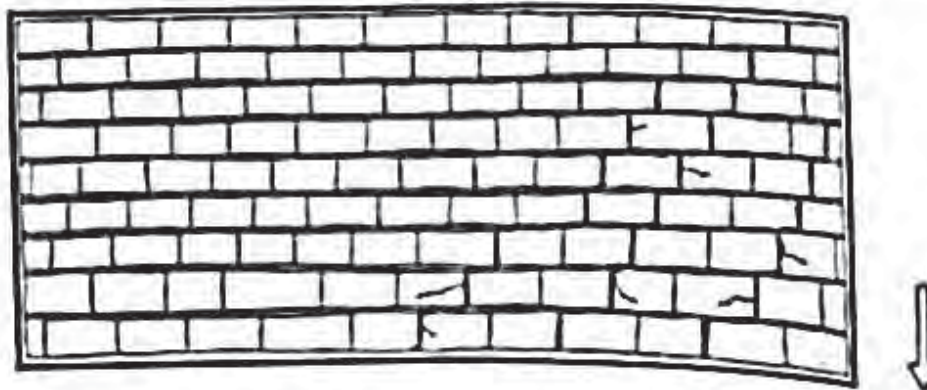

b) Diagonal cracks in brick wall

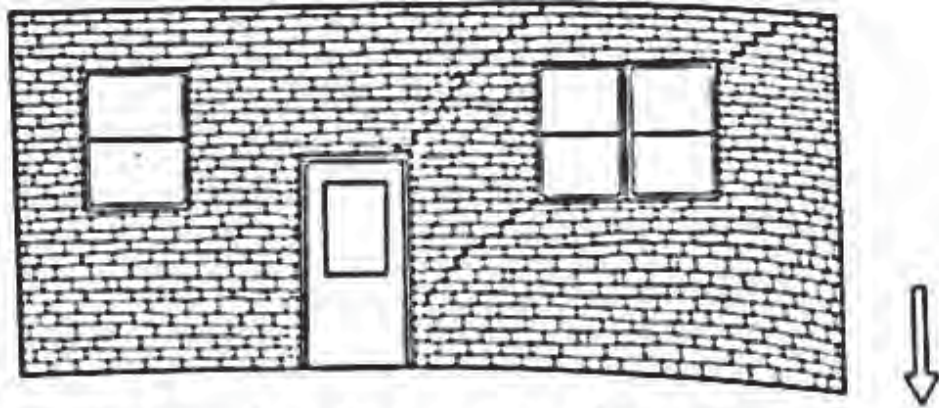

c) Diagonal cracks in masonry wall  
(extending upward in the direction of  
greater settlement side)

Figure 4: Differential Settlement Damage (Engineers International)

### 1.2.2 Tensile Horizontal Strain

Tensile Horizontal Strains occur on the edges of the subsidence trough in longwall mining.

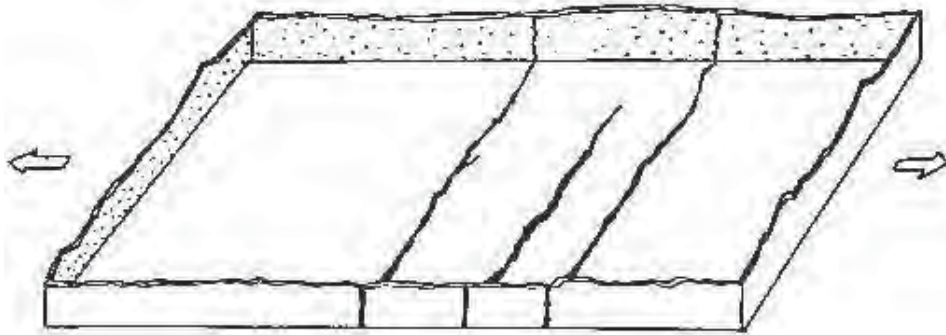

a) Cracks in basement floor

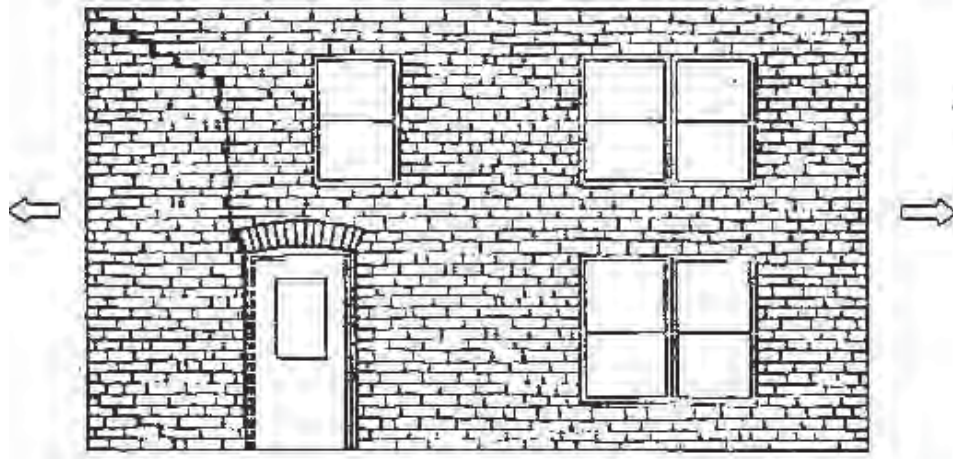

b) Vertical and step-like cracks along mortar-brick interfaces

Figure 5: Tensile Horizontal Damage (Engineers International)

### 1.2.3 Compressive Horizontal Strain

Compressive horizontal strains occur in the middle of and just outside of the subsidence trough in longwall mining. Often, a structure will exhibit both tensile and compressive damage, as it experiences both types of strain during the passage of the subsidence “wave” as the longwall passes beneath the structure.

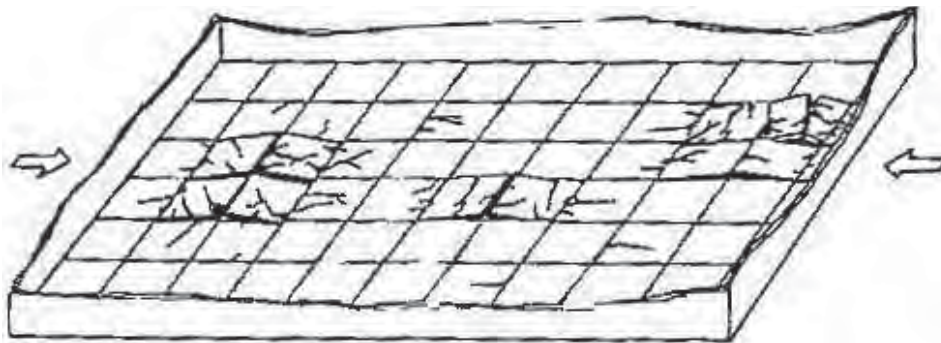

a) Heaving of basement floor tiles

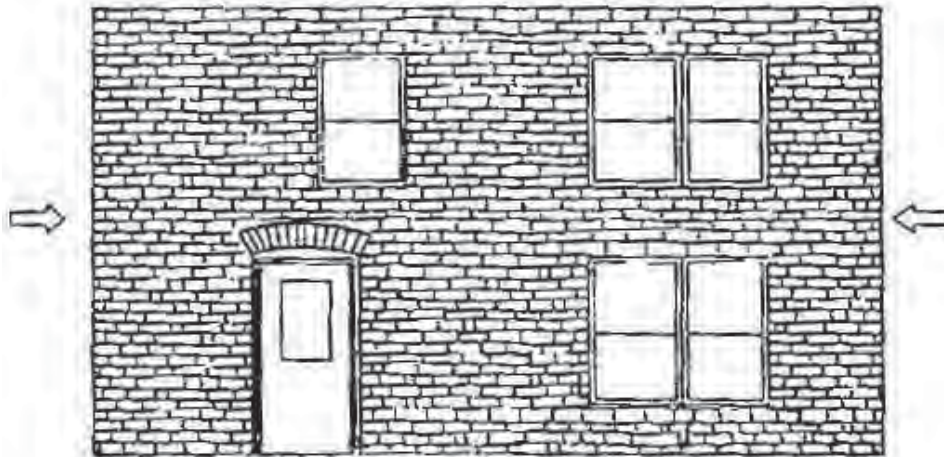

b) Cracks in masonry wall

Figure 6: Compressive Horizontal Damage (Engineers International)

### 1.2.4 Curvature

At the edges of the subsidence trough, structures may experience curvature of the ground beneath. Great care should be taken in mine planning to avoid having any structures located in the area where curvature is permanent.

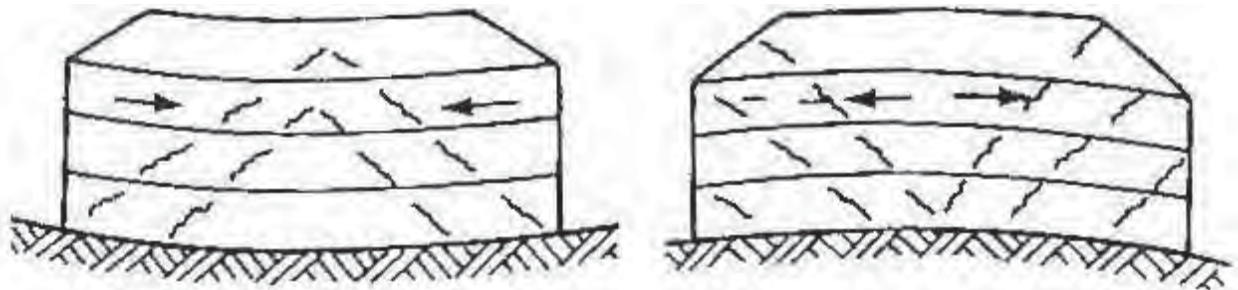

Figure 7: Curvature Damage (Engineers International)

## 1.2 Magnitude of Surface Structural Damages

Attempts have been made to quantify the amount of strain that a building/structure can withstand. However, there are so many variables that at smaller levels, it's very hard to quantify. Here are several examples from the SME 2011 Handbook:

Class of Damage	Description of Damage*	Repair	Approximate Width of Cracks, mm†
Negligible	Hairline cracks	None	<0.1
Very slight	Cracks in exterior brickwork visible upon close inspection; possible isolated slight fracture in building	Fine cracks easily treated during normal redecoration	<1
Slight	Several slight fractures inside building; visible external cracks; doors and windows may stick slightly	Cracks easily filled; redecoration probably required; some repointing may be required for weather tightness	<5
Moderate	Doors and windows sticking; weather tightness often impaired; utility service may be interrupted	Cracks may require cutting out and patching; recurrent cracks can be masked by suitable linings; repointing and possibly replacement of a small amount of exterior brickwork may be required.	5-15, or several cracks >3 mm
Severe	Windows and door frames distorted; floor slopes noticeably; walls lean or bulge noticeably; some loss of bearing in beams; utility service disrupted	Extensive work involving removal and replacement of sections of walls, especially over doors and windows	15-25, also depends on number of cracks
Very severe	Beams lose bearing, walls lean badly and require shoring; windows broken by distortion; danger of instability	Major work involving partial or complete reconstruction	Usually >25, depends on number of cracks

Table 1: Classification of Building Damage (SME Handbook 2011)

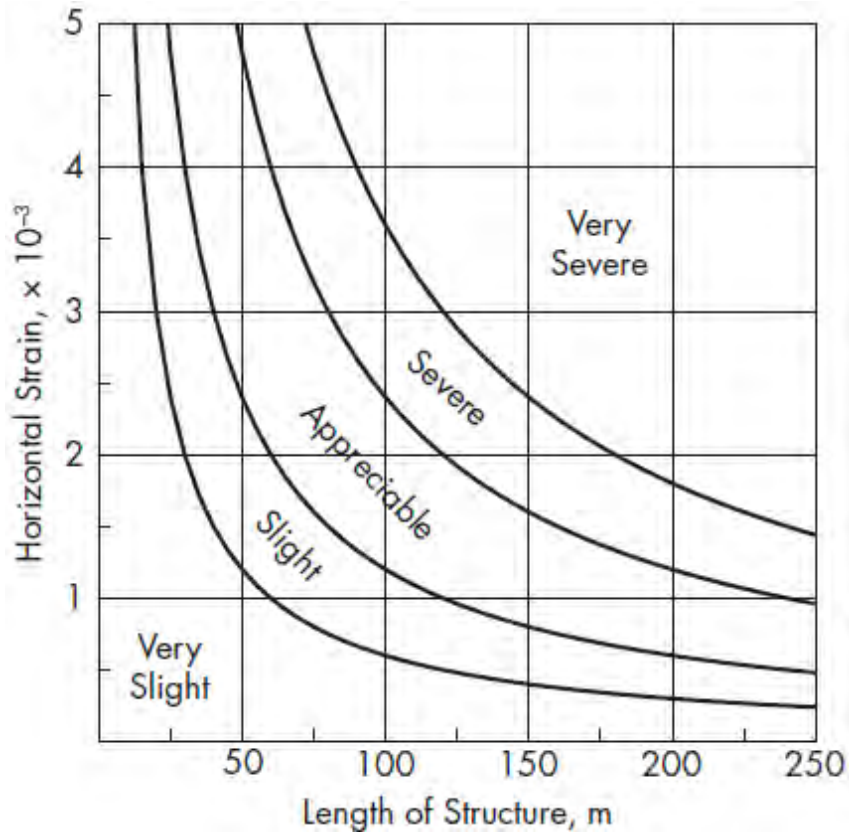

Figure 8: Building Damage in terms of Length of Structure vs. Horizontal Strain (SME Handbook 2011)

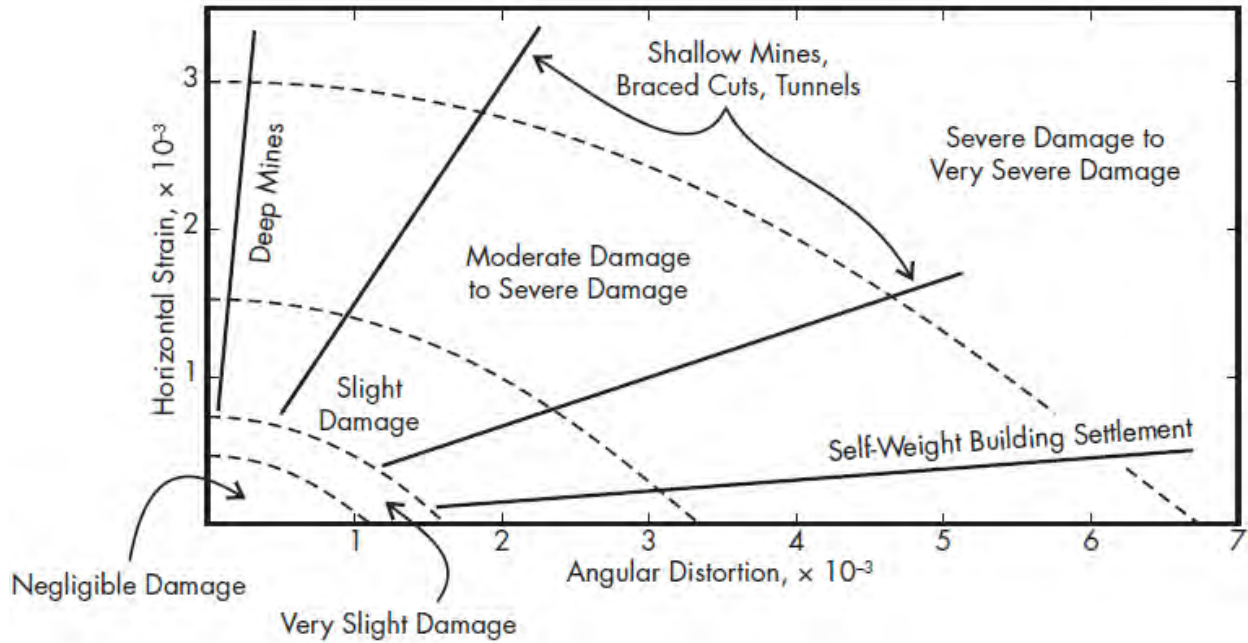

Figure 9: Building Damage in terms of Angular Distortion and Horizontal Strain (SME Handbook 2011)

## References, Chapter 4

Darling, P. (Ed.) 2011. *SME Mining Engineering Handbook, 3<sup>rd</sup> Edition*. Denver, CO. Society for Mining, Metallurgy, and Exploration, Inc.

Harrison, J.P. *Chapter 8.9 – Mine Subsidence*.

National Coal Board. 1975. *Subsidence Engineers' Handbook*. London: National Coal Board, Mining Department.

Orchard, R.J. (1956-1957) "Surface Effects of Mining – The Main Factors" *Trans. I. Min. E.*, 116, Parts I and II, 942-958.

Property Claim Services and Engineering and Safety Service of American Insurance Services Group (PCS), 1990. "Blasting Damage and Other Structural Cracking: A Guide for Adjusters and Engineers (Third Edition)."

Siskind, D.E., M.S. Stagg, J.W. Kopp, and C.H. Dowding, "Structure Response and Damage Produced by Ground Vibration from Surface Blasting." Bureau of Mines, Report of Investigation 8507 (1980).

Toenen, J.R. and S.L. Windes, "Seismic Effects of Quarry Blasting." Bureau of Mines, Bulletin 442 (1942).

Walker, J.S. and LaScola, J.C. "Foundation Response to Subsidence-Induced Ground Movements: A Case Study." Bureau of Mines, Report of Investigations 9224 (1989).

Whittaker, B.N. and Reddish, D.J. 1989. *Subsidence: Occurrence, Prediction and Control*. Department of Mining Engineering, The University of Nottingham, United Kingdom.

Chapter 17: "Effects of Mining Subsidence on Surface Structures, Design Considerations and Precautionary Measures."

Chapter 32: "Mining Subsidence in Longwall Mining with Special Reference to the Prediction of Surface Strains."



### Subsidence Monitoring



---

---

---

---

---

---

---

---

### Monitoring Planned Subsidence

- 1. Monitoring surface movements
- 2. Monitoring subsurface movements

---

---

---

---

---

---

---

---

### Surveying Surface Subsidence

- Survey line layout and monument spacing
- Monument design
- Accuracy of surveying

---

---

---

---

---

---

---

---

### Surveying Surface Subsidence Survey line layout

- Lines should cover both transverse and longitudinal directions
- Lines should extend beyond any potential angle of draw
- If possible extend line across chain pillar and monitor through pass of both panels
- Space at 5 percent of depth

---

---

---

---

---

---

---

---

### COMPREHENSIVE MONITORING PLAN

FIGURE 1

---

---

---

---

---

---

---

---

Monitoring for angle of draw

Monitoring for maximum subsidence

Monitoring to produce post subsidence contours

---

---

---

---

---

---

---

---

## Monument design

- Life of monitoring 2 weeks or 2 years?
- If long term, monuments should be designed to negate the impacts of natural ground fluctuations and frost heave

---

---

---

---

---

---

---

---

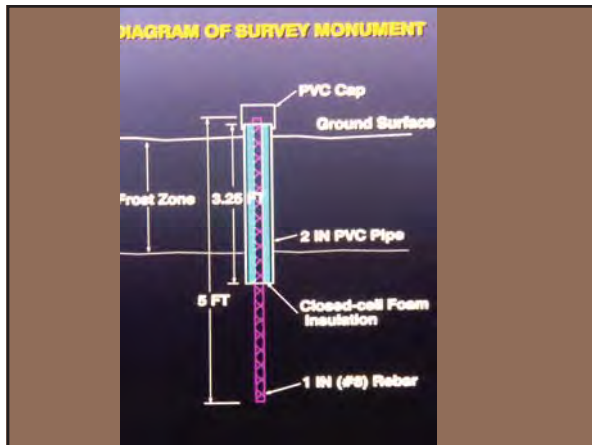

---

---

---

---

---

---

---

---



---

---

---

---

---

---

---

---



---

---

---

---

---

---

---

---

### Subsurface Instrumentation

- MPBX (multi point borehole extensometer)
- Inclinometer
- TDR (Time Domain Reflexometer)
- Sondex

---

---

---

---

---

---

---

---

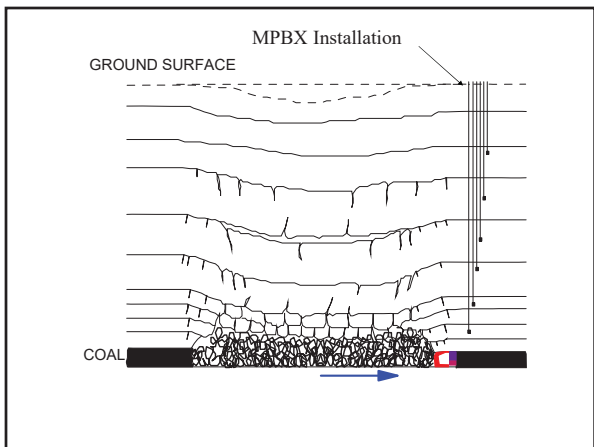

---

---

---

---

---

---

---

---

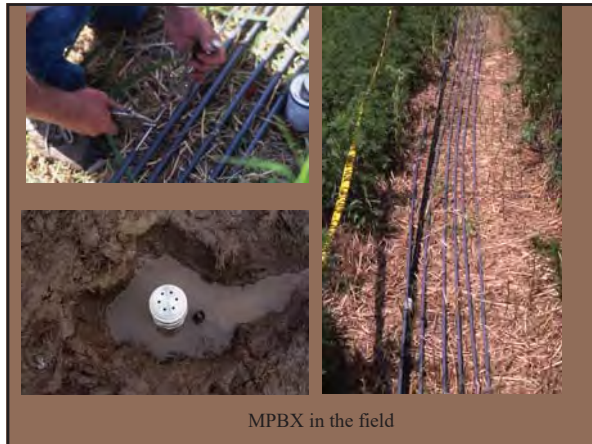

---

---

---

---

---

---

---

---

### Inclinometer

- Device to determine the change in inclination down a borehole

---

---

---

---

---

---

---

---

### Time Domain reflectometry

- Cable tester adapted to ground movement detection application

---

---

---

---

---

---

---

---



---

---

---

---

---

---

---

---

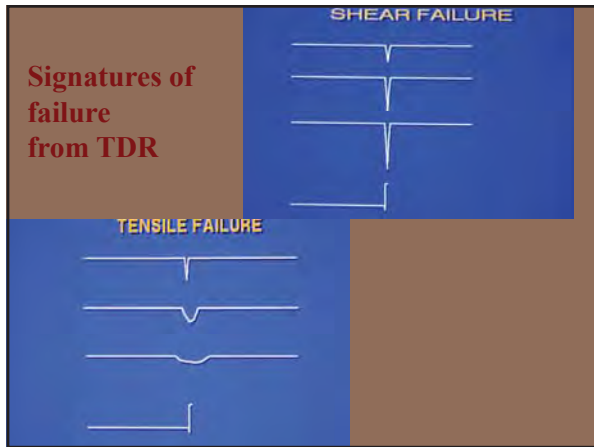

---

---

---

---

---

---

---

---

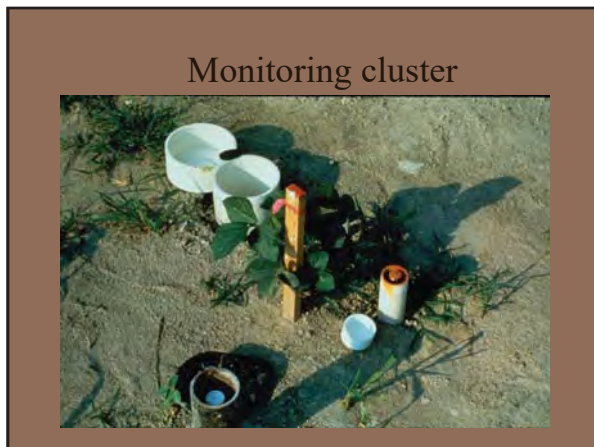

---

---

---

---

---

---

---

---

## CONDUCTING SUBSIDENCE INVESTIGATIONS AND MAINTAINING RECORDS

Mike Richmond

---

---

---

---

---

---

---

---

## Why Might We be Conducting a Subsidence Investigation?

- Citizen Complaint
  - Land/Home Owner – Structural or Land Damage
  - Environmental Group – Stream Loss
- Infrastructure Damage
  - Roads
  - Pipelines
  - Communications
- Injury
  - Sinkholes
  - Cracks

---

---

---

---

---

---

---

---

## What do All These Have in Common

- A Requirement for a Determination of Liability
  - Operator Performing Active Mining
  - AML Program – Pre-Law Mining
  - Other Non-Mining Causes
- Possibility of Litigation

Rigorous Documentation is Critical

---

---

---

---

---

---

---

---

## What Must We Accomplish Using Our Documentation

- Substantiate Visual Observations
  - Photographs – With Captions or Narrative Descriptions
  - Field Notes
  - Sketches
  - Maps - With Notations
- Provide a Record of the Sequence of Accumulation of Evidence Leading to the Investigations Conclusions

---

---

---

---

---

---

---

---

## Typical Sequence of Activities During a Subsidence Investigation

- Receive Complaint
- Make Initial Site Visit
- Review Permit Documents
- Review Non-SMCRA Documents
  - MSHA Ventilation Maps
  - MSHA Roof Control Issue Reports
- Review Associated State and Federal Regulations
- Revisit the Site, if Necessary
- Assemble and Evaluate Collected Evidence
- Draw and Report Conclusions

---

---

---

---

---

---

---

---

## Receipt of Complaint

- Subsidence Damage Complaints May be Filed by:
  - A Person – Land or Home Owner
  - Group – Environmental or Political
  - Entity – Corporation; or Local, County, or State Authority, such as a Town or a State Department of Transportation

---

---

---

---

---

---

---

---







---

---

---

---

---

---

---

---



---

---

---

---

---

---

---

---



---

---

---

---

---

---

---

---



---

---

---

---

---

---

---

---

**Receipt of Complaint**

- Land Damage
  - Surface Cracking
  - Stream or Pond Dewatering

---

---

---

---

---

---

---

---



---

---

---

---

---

---

---

---



---

---

---

---

---

---

---

---



---

---

---

---

---

---

---

---



---

---

---

---

---

---

---

---

## Initial Site Visit

- Write Ongoing Narrative of Site Visit, Identifying All Personnel Onsite, and their Affiliations
  - Note Date, Time, and Current and Recent Weather Conditions
  - Verify All Damage Alleged by the Complainant
  - Photograph Damage, Note Photograph in Narrative, and Provide Detailed Description of Damage
  - Note Location of Damage on a Sketch or, Preferably, on a Map of the Site
  - Avoid Drawing Premature Conclusions and, Absolutely do Not Voice Opinions at this Stage

---

---

---

---

---

---

---

---



---

---

---

---

---

---

---

---



---

---

---

---

---

---

---

---

## Documents Provided at Time of Initial Site Visit

- Documents Provided by the Regulatory Authority
  - Permit Documents, Pre-Mine Survey Maps, Well Complaints, etc.
- Documents Provided by the Operator
  - Maps of Previous Mining
- Documents Provided by the Complainant
  - Affidavits, Statements of Observation of Damage or Site Prior to Active Mining
  - Pre-Mine Surveys, Damage Logs, or Inspection Reports
  - Photographs

---

---

---

---

---

---

---

---

---

---

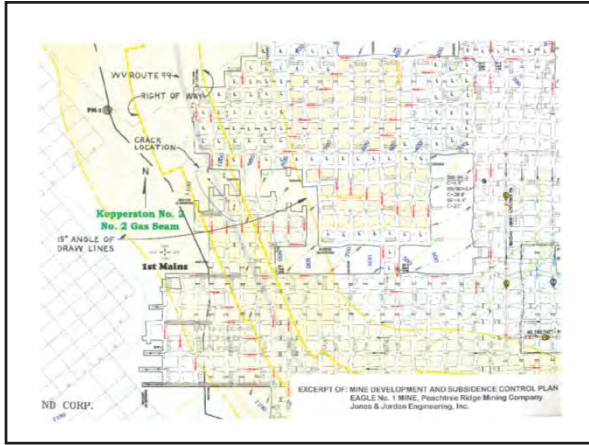

---

---

---

---

---

---

---

---

---

---

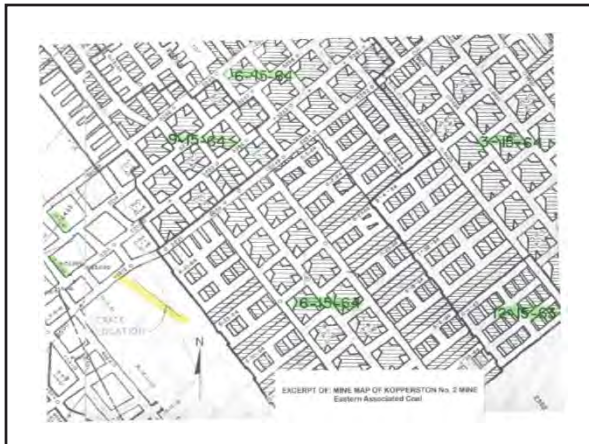

---

---

---

---

---

---

---

---

---

---

## Review Permit Documents

- Review Documents Provided by the Regulatory Authority at the Time of the Site Visit
  - Permit Documents, Pre-Mine Survey Maps, Waivers, Well Complaints, etc.
- Research Permit File for Any Pertinent Information that May Not Have Been Provided
  - Type of Mining
    - Longwall Mining
    - Room and Pillar Development or First Mining
    - Room and Pillar Retreat Mining
    - Extraction Ratio

---

---

---

---

---

---

---

---

---

---



---

---

---

---

---

---

---

---

---

---

## Review Permit Documents

- Research Files of Any Permits for Previous Mining at the Site
  - Dated Mine Progress Maps
- Determine if Any AML Projects have Occurred at the Site
  - Review Files of Any AML Projects at the Site

---

---

---

---

---

---

---

---

---

---

## Review Non-SMCRA Documents

- MSHA Documents Related to Active and Past Mining
  - Dated Ventilation Progress Maps
  - Any Reports Related to Roof or Pillar Control Issues
- Documentation of Any Earthwork Conducted at the Site
- Documentation of Highway or Utility Construction at the Site
- Logs of Damage Monitoring if Available

---

---

---

---

---

---

---

---

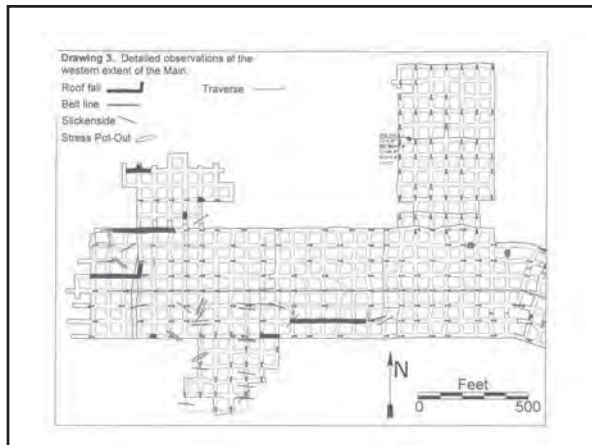

---

---

---

---

---

---

---

---

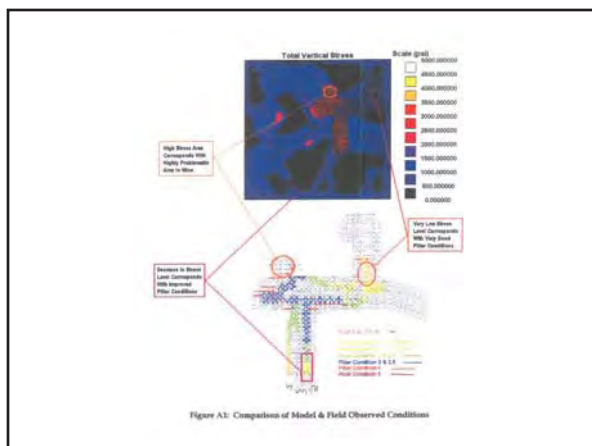

---

---

---

---

---

---

---

---



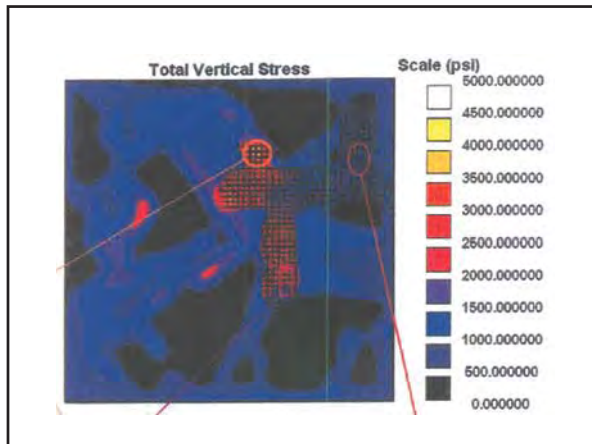

---

---

---

---

---

---

---

---

---

---

---

---

(RM)  
8/4/06 FOUND VOID ON ET 99 BY DAN  
CLAW WORKING IN EAST AREA.  
J. Neely checked void that runs  
E-W on yellow line in center of  
ROAD measures 17 feet in length  
and approx 2" in width. Asphalt  
is breaking up around crack  
and ROAD IS SUBSIDING AND UNUSUAL.  
NOTIFIED MIAMI ROAD. HE CAME ON  
AND INSPECTED ROAD AND NOTIFIED  
E. TUCKERLINE AND DEP. DEP  
CHECKING VOID TO TRY AND DETERMINE  
CAUSE IF POSSIBLE. HOLE NEXT TO  
(LEFT) HIGHWAY WITH SIGNIFICANT AIR.  
8/16/06 J. Neely checked ROAD SPOT and  
8:30 am there was no change.  
(SUM)  
8/16/06 J. Neely checked ROAD AND THERE  
9:00 am was no change in ROAD  
CONDITION.

---

---

---

---

---

---

---

---

---

---

---

---

### Review Associated State and Federal Regulations

- Regulations Related to Allowable Subsidence
  - Angle of Draw
  - Right to Subside
  - Protected Structures
- Regulations Related to Extraction Ratios
  - Exemption from Pre-Mining Survey
- Regulations Related to Mitigation of Damage
  - Presumption of Causation
  - Requirements to Mitigate Damage

---

---

---

---

---

---

---

---

---

---

---

---

## Revisit Site – If Necessary

- Determine if Damage Has Progressed Since Initial Site Visit
  - Can Confirm that Damage is Current and Ongoing, Rather than Old Damage
  - Can Identify if Conditions have Developed that Should be Addressed Quickly, for Safety Reasons
  - Can Obtain Additional Information Regarding Issues Identified During the Investigation

---

---

---

---

---

---

---

---

## Assemble and Evaluate Collected Evidence

- Ongoing Process
  - Track Reasoning Throughout Process
    - Seriously Consider Using a Field Book
  - Recognize that Opinions Often Change as New Evidence is Introduced
  - Collect All Available Evidence, Identifying Possible Contributing Factors
  - Evidence will Identify Factors that are Unlikely to have Contributed to the Damage, and can be Eliminated
  - Note that there May be Multiple Contributing Factors

---

---

---

---

---

---

---

---

## Record Keeping

- Why is Record Keeping so Important when Performing a Subsidence Investigation?
  - Possibility of Litigation
    - Investigations are Most Often Conducted When Parties Involved do not Agree on Who is Liable
    - There is a High Probability your Conclusions will be Contested
    - The More Meticulous and Better Organized your Record Keeping – the Better your Chances of Defending your Conclusions
  - In Many Cases, Well Organized, Meticulous Records Discourage Contestation of Conclusions

---

---

---

---

---

---

---

---

## Record Keeping

- Begin Project File Immediately Upon Initiation of Investigation
  - Begin Tracking of Reasoning Document
- How Might you Want to Organize your Records?
  - Organize by Source (Separate Folder For Each Source)
  - Date (Date Document was Acquired) Each Document, and Place in Chronological Order
  - Tab Specific Pages of Each Document, Identifying Information Used to Draw Conclusions
  - Reference Each Document in the Tracking of Reasoning Document

---

---

---

---

---

---

---

---

## QUESTIONS?

---

---

---

---

---

---

---

---

### Subsidence Investigation Tools

- What Headings Might Subsidence Investigation Tools Fall Under?
  - Measurement
  - Recording
  - Documentation
  - Information
  - Location

---

---

---

---

---

---

---

---

### Measurement Tools

- 100 – 300 Foot Tape Measure
- Rule or 6 Foot Tape Measure
- 4 Foot Level
- Compass
- Protractor
- Scale

---

---

---

---

---

---

---

---



---

---

---

---

---

---

---

---

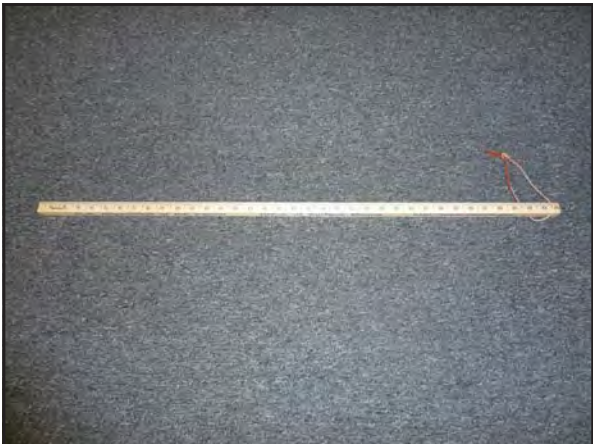

---

---

---

---

---

---

---

---



---

---

---

---

---

---

---

---

**Measurement Tools**

- Clinometer – Abney Level
- GPS Unit
- Google Earth
- Survey Equipment (Total Station)
- Plumb Bob
- Laser Rangefinder

---

---

---

---

---

---

---

---



---

---

---

---

---

---

---

---

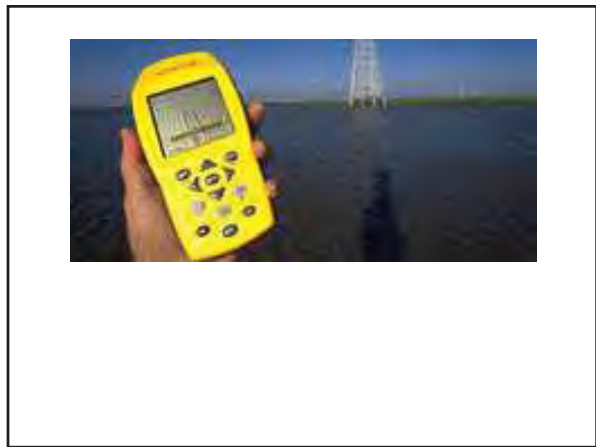

---

---

---

---

---

---

---

---



---

---

---

---

---

---

---

---

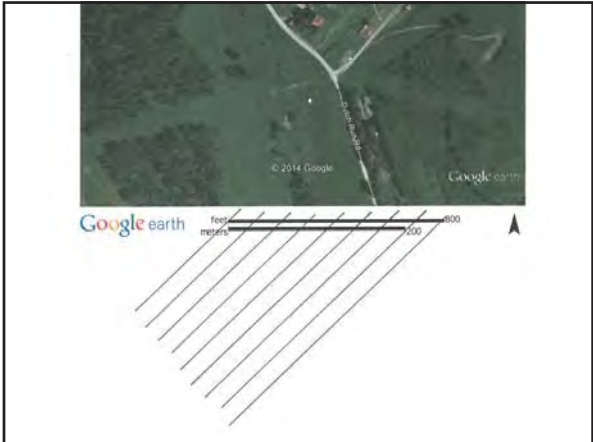

---

---

---

---

---

---

---

---



---

---

---

---

---

---

---

---



---

---

---

---

---

---

---

---



---

---

---

---

---

---

---

---



---

---

---

---

---

---

---

---



---

---

---

---

---

---

---

---





---

---

---

---

---

---

---

---

### Measurement Tools

- Water Level Indicator
- Flow Measuring Equipment (Air or Water)
- pH, Iron, Manganese, Aluminum and Selenium Test Equipment
- Down-Hole Camera
- Water Sampling Equipment (Bailer & Line)
- Sample Containers and Stabilizing Agents
- Combustible Gas Indicator (CGI)

---

---

---

---

---

---

---

---

### Recording Tools

- Camera
- Laptop or Tablet Computer
- GPS Unit
- Tape, Audio, or Video Recorder

---

---

---

---

---

---

---

---

**Documentation Tools**

- Camera
- Tape, Audio, or Video Recorder
- Note Pad
- Sketch Book or Pad
- Field Book
- Drawings or Maps

---

---

---

---

---

---

---

---

**Information Tools**

- Active Mining Maps
- Past Mining Maps
- Investigative Reports from Other Agencies
  - MSHA
- Damage Logs
- Historical Photos
- High Resolution Before & After Digital Models

---

---

---

---

---

---

---

---

**Safety Tools**

- Hard Hat
- Boots
- Safety Glasses
- Snake Chaps
- Pepper Spray
- Bug Spray
- Walking Stick or Staff

---

---

---

---

---

---

---

---



---

---

---

---

---

---

---

---

**Questions?**

---

---

---

---

---

---

---

---

**Remove the Structure away during Mining**



---

---

---

---

---

---

---

---

**Fill the Sinkhole with Concrete**



---

---

---

---

---

---

---

---

**Home reset on new foundation after completion of subsidence movements**



---

---

---

---

---

---

---

---

House floating is the most common practice used to minimize structural damage to buildings



---

---

---

---

---

---

---

---



---

---

---

---

---

---

---

---



Plywood placed around foundation to keep home warmer over the winter

Home owners remain in house. May leave for a few days to a week during major subsidence

---

---

---

---

---

---

---

---

### 38 inch high pressure oil transmission line



---

---

---

---

---

---

---

---

### Mitigation Measures to Minimize damage

- Trenching
- Reinforcing with Steel Cables
- Tension with Nylon Ropes
- Slotting
- Cribbing
- Bracing- Windows/Doors/Attic
- Controlled Mining Technique

---

---

---

---

---

---

---

---

### Trenching Technique



---

---

---

---

---

---

---

---

Steel Cables Around the House



---

---

---

---

---

---

---

---



---

---

---

---

---

---

---

---

Slot in Concrete



---

---

---

---

---

---

---

---



---

---

---

---

---

---

---

---



---

---

---

---

---

---

---

---

**Control Mining Technique**

- Mining Continuously within the influence zone of the structure
- Mining without stopping for 600 feet, 200 feet before and 400 feet after the longwall face has passed the structure
- In doing so the structure will undergo only dynamic strains which are 2 to 3 times smaller than static strains

---

---

---

---

---

---

---

---



### Location of the Structure

- The panel width is supercritical which means width is  $> 1.2 \times$  depth
- The final maximum strain caused by subsidence near the panel center is zero
- The structure is located 486 feet from the panel center which is 1016 feet wide – almost near the panel center

---

---

---

---

---

---

---

---

### Mine Map

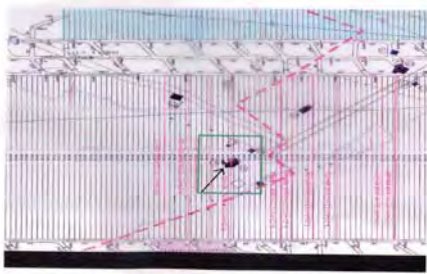

WIDTH - 1000ft. DEPTH - 450ft. MINING HEIGHT - 7 ft

---

---

---

---

---

---

---

---

### Location of Structure

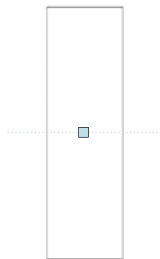

---

---

---

---

---

---

---

---

### Before Mining



---

---

---

---

---

---

---

---

### Subsidence Profile Predicted

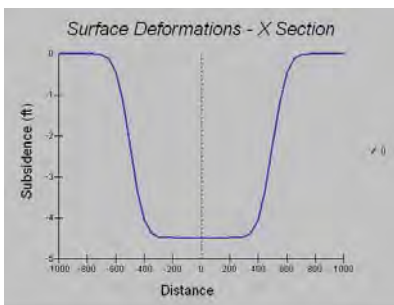

---

---

---

---

---

---

---

---

### Strain Profile Predicted

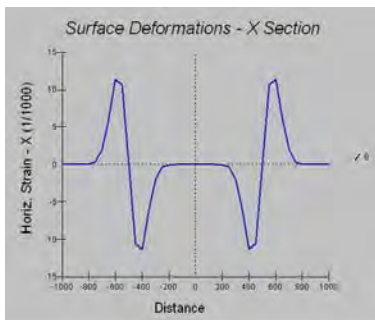

---

---

---

---

---

---

---

---

### Illinois Longwall Experience

- Cropland
- Homes and buildings
- Public highways
- Railroads
- Major Pipelines
- Perennial streams
- Methane gas plant
- Capped slurry impoundment

---

---

---

---

---

---

---

---

### SUBSIDENCE CONTROL PLAN Land

- Existing and projected contours required
- Projected Contours define potential drainage problems
- Drainage interruptions must be corrected
- Addition of drainage tile may be needed to supplement surface drainage
- Temporary crop damage compensation is required until repair is complete

---

---

---

---

---

---

---

---

### Performance Standards for Subsidence Impacts

1. All land must be restored to its pre-mining capability
2. All structures must be repaired, replaced or compensated for
3. All drinking and domestic water supplies (wells and springs) must be restored or replaced

---

---

---

---

---

---

---

---

**Structures**  
**What can Industry do?**

- Restore purchased structures for sale/reuse
- If not practical, remove the damaged structures (remove the eye sore).
- Work closely with road authorities and utilities to assure quick repair
- Make noticeable improvements when possible

---

---

---

---

---

---

---

---

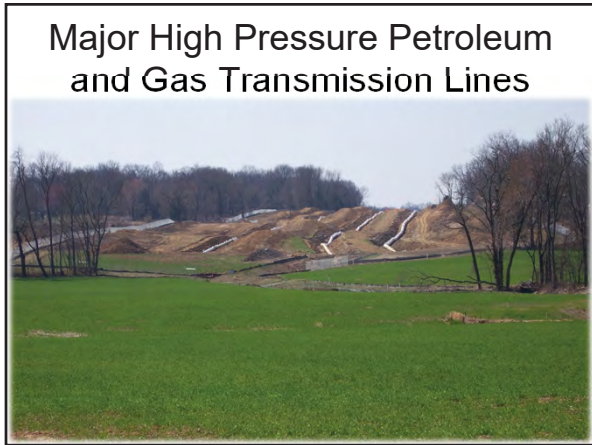

---

---

---

---

---

---

---

---

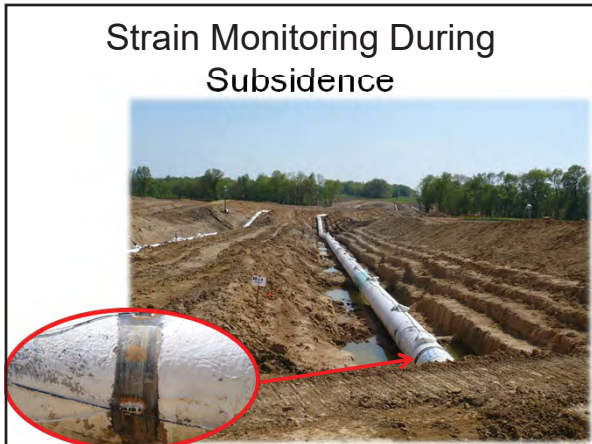

---

---

---

---

---

---

---

---

### Roads & Longwall Subsidence



---

---

---

---

---

---

---

---

Rail has been raised and ballast added to remove subsidence profile. Un-subsided gate roads create drainage problems

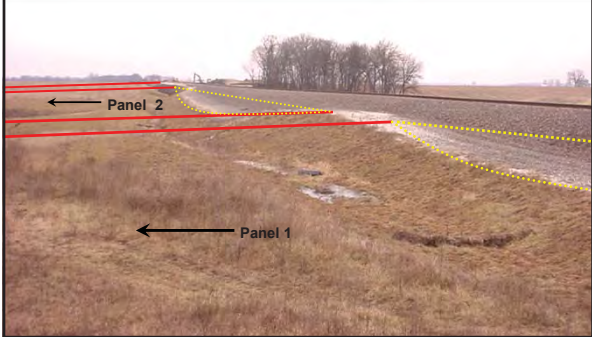

---

---

---

---

---

---

---

---

Gate road cut through to relieve drainage problem



---

---

---

---

---

---

---

---

Flat Topography and Longwall Mining



---

---

---

---

---

---

---

---



---

---

---

---

---

---

---

---

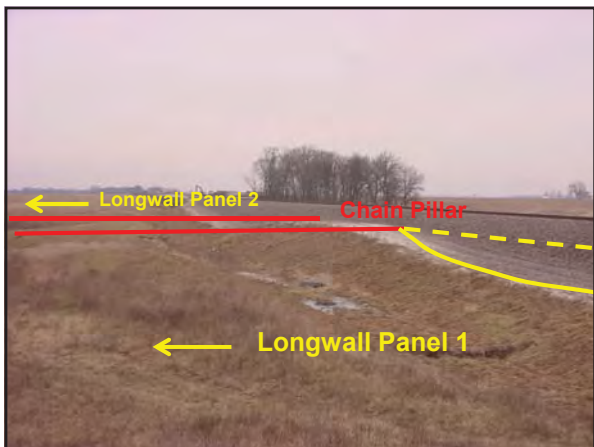

---

---

---

---

---

---

---

---



---

---

---

---

---

---

---

---



---

---

---

---

---

---

---

---



---

---

---

---

---

---

---

---

“I” Beams for Floating



---

---

---

---

---

---

---

---



---

---

---

---

---

---

---

---

Reset several months after pass of longwall



---

---

---

---

---

---

---

---



Utility precautions during  
subsidence



---

---

---

---

---

---

---

---



---

---

---

---

---

---

---

---



---

---

---

---

---

---

---

---



---

---

---

---

---

---

---

---



---

---

---

---

---

---

---

---



---

---

---

---

---

---

---

---



---

---

---

---

---

---

---

---

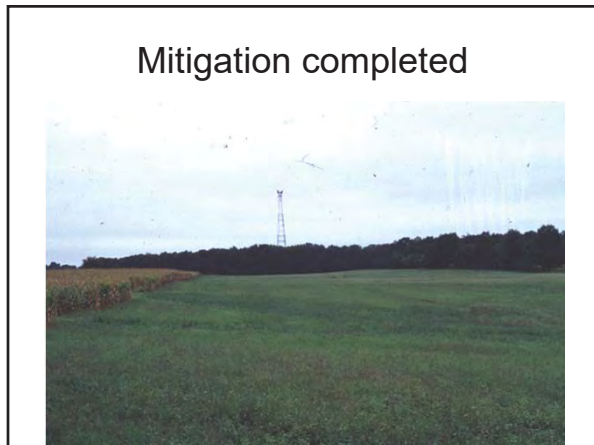

---

---

---

---

---

---

---

---



---

---

---

---

---

---

---

---

Restored Drainage



---

---

---

---

---

---

---

---

Drainage problems from chain pillars between subsidence troughs



---

---

---

---

---

---

---

---

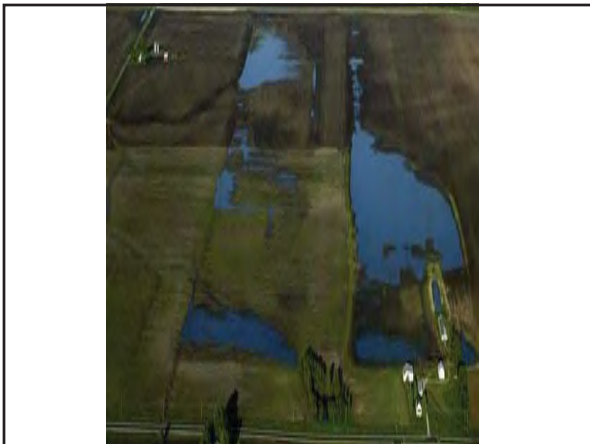

---

---

---

---

---

---

---

---

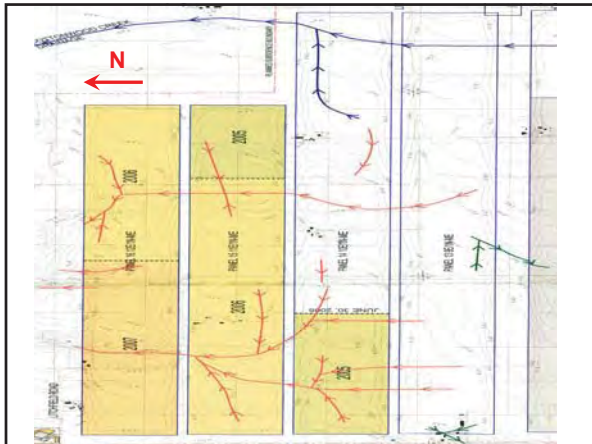

---

---

---

---

---

---

---

---

Drainage problems from chain pillars between subsidence troughs



---

---

---

---

---

---

---

---

Corrected Drainage

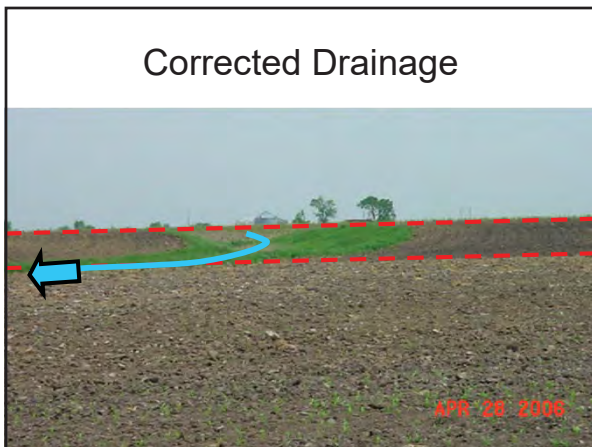

---

---

---

---

---

---

---

---



---

---

---

---

---

---

---

---



---

---

---

---

---

---

---

---



---

---

---

---

---

---

---

---



---

---

---

---

---

---

---

---



---

---

---

---

---

---

---

---



---

---

---

---

---

---

---

---

## **CHAPTER 8:**

### **SUBSIDENCE**

### **PREDICTION METHODS**

Kewal Kohli  
Stefanie Self



## 8.1 OVERVIEW OF SUBSIDENCE PREDICTION METHODS

There are several methods developed for predicting the final subsidence and the subsidence profiles. The methods to predict subsidence can be divided into various methods:

- Graphical Methods - Profile Function Methods
- Influence Function Methods
- Numerical Modeling Methods
- Empirical Methods

The models based on theoretical and numerical methods usually require extensive information about the properties of the overburden to be properly calibrated for a particular field site. The models based on the empirical methods require an extensive set of field data.

## 8.2 GRAPHICAL METHODS

### 8.2.1 PROFILE FUNCTION METHODS

The Profile Function Method is essentially a curve-fitting method against the measured subsidence profiles in a particular region. There are many profile functions developed empirically for nearly all major coalfields in the world. These include for the United Kingdom, the National Coal Board - Subsidence Engineer's Handbook of 1975 and for the United States, Peng and Chen, 1981 and Karmis et al, 1984.

These are generally only applicable to single panels, since they assume the profiles to be symmetrical and fail to recognize the way in which subsidence shapes are modified over adjacent and previously mined areas.

For the SDPS software program, the following equation is used for the profile function calculation (these equations vary by method):

$$S(x) = \frac{1}{2} S_{max} \left\{ 1 - \tan \left[ \frac{cx}{B} \right] \right\}$$

$S(x)$  = Subsidence at  $x$

$x$  = distance from the inflection point

$S_{max}$  = maximum subsidence of the profile

$B$  = distance from the inflection point to point of  $S_{max}$

$c$  = constant

**Note:** This function was developed using statistical evaluation of data from the Eastern U.S. coalfields.

## 8.3 INFLUENCE FUNCTION METHODS

The Influence Function Method was first proposed by Bals in 1931. It was further developed by Knothe (1957), Liu and Liao (1965), Brauner (1973), and Marr (1975). This method is now widely used in the world, and can be applied to a wide range of mining geometries, but are more difficult to calibrate than profile function methods.

For the SDPS software, the influence function utilized is the bell-shaped Gaussian function. This method progresses and can simplify to the following formula for calculating subsidence at any given point P:

$$S(x, s) = \frac{1}{r} \int_{-x}^{+x} S_o(x) \exp \left[ -\pi \frac{(x - s)^2}{r^2} \right] dx$$

m = extraction thickness

a = roof convergence (or subsidence) factor

$S_o(x) = S_{\max}$  = maximum subsidence of the profile (if constant m & a)

$x_1$  and  $x_2$  are the limits of the excavation

r = the radius of principal influence =  $\frac{h}{\tan \beta}$

h = overburden depth

$\beta$  = angle of principal influence

## 8.4 NUMERICAL MODELING METHODS

Finite element has been used in difficult and complex situations. This is a numerical method and it can simulate nearly every conceivable material property, inhomogeneity, bedding planes, anisotropy, and various boundary conditions. It needs skilled personnel and more information which makes this model costly and time consuming and less attractive. While these tools are useful for investigating strata mechanisms and hydrological impacts, they have not yet been found to produce sufficiently accurate predictions of mine subsidence parameters.

## 8.5 EMPIRICAL METHODS

Empirical methods can be developed for the prediction of subsidence parameters whenever a large database of measured subsidence parameters is available. These methods can be advantageously employed over a wide range of mining geometries, taking into account local variations in strata lithology. Further information on these types of methods can be found in Kratzsch (1983) and Whittaker and Reddish (1989).

## 8.6 SOFTWARE PROGRAMS

Various models have been used in the US over the past decades, but we will briefly discuss the following:

- 1) Subsidence Deformation Prediction System (SDPS – VPI & SU)
- 2) LaModel (WVU)
- 3) Comprehensive and Integrated Subsidence Prediction Model (CISPM – WVU)
- 4) NIOSH Ground Control Software

### 8.7.1 SUBSIDENCE DEFORMATION PREDICTION SYSTEM (SDPS - VT)

SDPS can be obtained through OSMRE's TIPS program for all SMCRA programs – contact your TIPS Service Manager for the program (for industry customers, purchase can be done through Carlson Software). It was developed by Dr. Karmis and Dr.

Agioutantis through Virginia Tech, and is updated periodically by Dr. Agioutantis.

SDPS can predict the vertical subsidence, horizontal displacement, tensile and compressive strains, slope and curvature. It is a computer friendly, easy to use and predicts within reasonable accuracy. The output can be in text, table, graph or CAD-compatible format. The current installation package for SDPS also includes copies of the NIOSH Ground Control Software, see section 4.7.4.

There are four separate modules within SDPS:

- 1) Profile Function
  - a. Easiest to apply
  - b. Minimum input needed: panel width, overburden depth, seam thickness, and percent hardrock in the overburden
  - c. Location of prediction points automatically established along the transverse axis of the panel
  - d. Empirical parameters are already built into the profile function equation
- 2) Influence Function
  - a. More inputs required for the influence function, with the following steps usually followed:
    - i. Establish the mine plan
    - ii. Establish the location of the prediction points
    - iii. Develop empirical parameters pertaining to each case study
    - iv. Time parameter
- 3) Pillar Stability Analysis Module – to be discussed in the Pillar Design chapter
- 4) Graphing Module – for display of results

**UPDATE from Agioutantis et al, 2014:** Original programming for SDPS was done using mainly Appalachian coalfield data. Due to this “bias” in the software, some of the other areas of the country were not satisfied with the results of the analysis performed using SDPS. In 2007, OSMRE funded further software development to take into account data from the Illinois coal basin. Illinois coal bearing strata creates unique and challenging mining conditions and unique subsidence conditions. The immediate floor is often a weak clay-rich rock (underclay or fireclay) and of a highly variable thickness. Pillar punching and floor heave can be highly variable and unpredictable. A paper is available in your reference material describing the modifications to the software that were done for this region.

### 8.7.2 LAMODEL (WVU)

LaModel has been developed by Dr. Keith Heasley with West Virginia University (WVU) since 1994, and is available here:

<http://web.cemr.wvu.edu/~kheasley/LaModelDownloads/>. This is a numerical modeling software package, and is usually used in more complex mining situations, such as multiple seam mining, complex mine geometries, yielding pillars and variable topography. The use of this program is more complex than SDPS, but support is

available from NIOSH, WVU and OSMRE.

### **8.3.3 COMPREHENSIVE AND INTEGRATED SUBSIDENCE PREDICTION MODEL (CISPM - WVU)**

Developed by West Virginia University, available here:

<http://web.cemr.wvu.edu/~yluo/CISPM.htm>

A computer program package for predicting surface subsidence induced by underground mining operations. The development of the prediction package is based on the influence function method that is widely adopted in the major mining countries including US coal mining industry. The findings from our researches in the last 15 years on mining subsidence have been incorporated into this package. The prediction model has been validated by a large amount of field data. It has been successfully employed in numerous cases of assessing the subsidence influences on as well as designing and implementing mitigation measures for various surface structures.

### **8.7.4 NIOSH GROUND CONTROL SOFTWARE**

Suite of software programs developed by NIOSH and distributed via:

<http://www.cdc.gov/niosh/mining/researchprogram/groundcontrol.html>. The ones in bold are the ones we will discuss in class. For more information, please see the NIOSH website.

- **Analysis of Longwall Pillar Stability (ALPS)**
- **Analysis of Retreat Mining Pillar Stability (ARMPS)**
- Coal Mine Roof Rating (CMRR)
- Analysis of Roof Bolt Systems (ARBS)
- Analysis of Horizontal Stress Effects in Mining (AHSM)
- Analysis of Multiple Seam Stability (AMSS)
- **Analysis of Retreat Mining Pillar Stability - Highwall Mining (ARMPS-HWM)**

#### **8.7.3.1 ANALYSIS OF LONGWALL PILLAR STABILITY (ALPS)**

Required by MSHA for permitting of underground coal mines, used for designing pillars for longwall mines. Estimates the load and load-bearing capacity within the mine, and calculates a stability factor (SF) from the calculations.

#### **8.7.3.2 ANALYSIS OF RETREAT MINING PILLAR STABILITY (ARMPS)**

Required by MSHA for permitting of underground coal mines, used for designing pillars for room-and-pillar retreat mining. Calculates the stability factor (SF) from estimated pillar loads and load-bearing capacity within a given design.

#### **8.7.3.3 ANALYSIS OF RETREAT MINING PILLAR STABILITY (ARMPS - HWM)**

Not currently required by MSHA for permitting of highwall coal mines. However, the program is being used in permit applications for highwall mines in the US. Calculates a stability factor (SF) for the web and barrier pillars associated with a highwall mine plan.

## References, Chapter 8

Agioutantis, Z., Barkley, D., Karmis, M. and Elrick, S. 2014. *Development of an Enhanced Methodology for Ground Movement Predictions Due to Longwall Mining in the Illinois Basin*. Proceedings of the 33<sup>rd</sup> International Conference on Ground Control in Mining. Morgantown, WV.

CISPM website: <http://www2.cemr.wvu.edu/~yluo/CISPM.htm>

Keith Heasley's website: <http://www2.statler.wvu.edu/~kheasley/>

Mine Subsidence Engineering Consultants. 2007. *General Discussion on Systematic and Non-Systematic Mine Subsidence Ground Movements*.

National Coal Board. 1975. *Subsidence Engineers' Handbook*. London: National Coal Board, Mining Department.

NIOSH Ground Control website: <http://www.cdc.gov/niosh/mining/topics/GroundControlOverview.html>

SDPS Help file

Whittaker, B.N. and Reddish, D.J. 1989. *Subsidence: Occurrence, Prediction and Control*. Department of Mining Engineering, The University of Nottingham, United Kingdom.

## **CHAPTER 9:**

# **COAL PILLAR MECHANICS AND DESIGN**

Kewal Kohli  
Stefanie Self

## 9.1 PILLAR PERFORMANCE

The most important part of the design of any underground mine is the support of the roof, so that miners can work safely while extracting the ore. Room-and-Pillar mining is used both on its own as a mining method, as well as development mining for Longwall mining. Rock or ore that is left in place for support, as well as any adjacent strata, must be thoroughly investigated and accounted for in the mine design. The investigation and study of these properties are usually grouped under the term "ground control", and will be discussed more in this chapter.

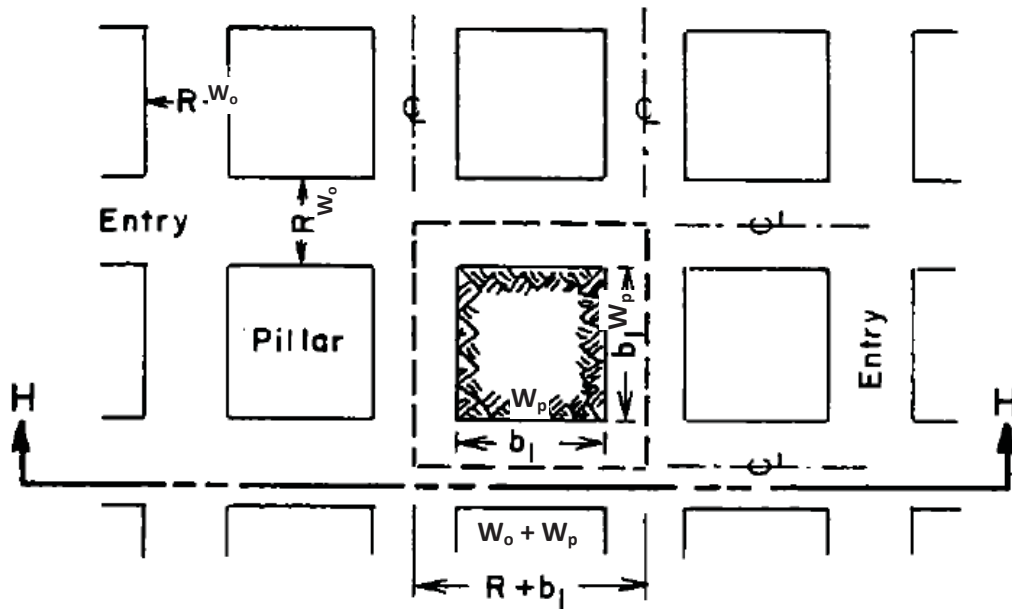

Plan view of room-and-pillar system

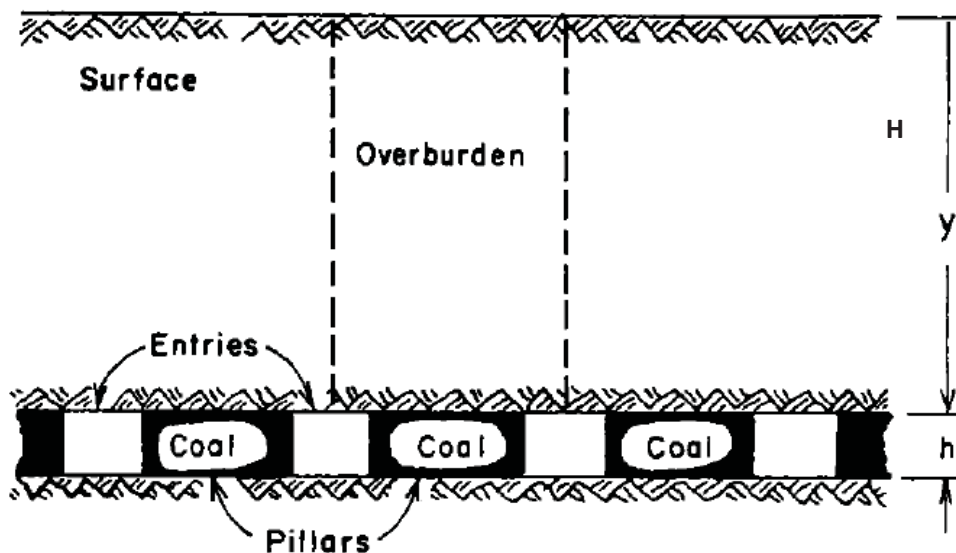

Figure 9.1 Vertical section H-H of a room and pillar system (modified from Babcock 1994)

## 9.2 MODES OF PILLAR FAILURE

Pillars may fail in several different ways, depending on whether the failure occurs in the pillar itself (usually composed of ore left in place), or the roof or floor strata. Strength of the rock stratas, amount of void space vs support left in place, faults and bedding planes, and water are some of the common factors that affect pillar performance.

Pillar failure includes any situation where the pillar no longer supports the amount of weight it was designed to hold. These failures can manifest in several different ways, such as:

- **Sudden, massive collapse**, accompanied by airblast, for slender pillars (width/height < 4)
- **Squeezing**, or slow, non-violent failure, for most room and pillar applications ( $4 < w/h < 10$ )
- **Entry failure or bumps** for deep cover and longwall applications ( $w/h > 10$ )

### 9.2.1 FAILURE DUE TO ROOF FAILURE

Roof in the areas between pillars (rooms) falls. Strata above the pillars can also yield/fall, which may lead to surface expression of the failure as a sag or sink hole (Figure 9.2.1).

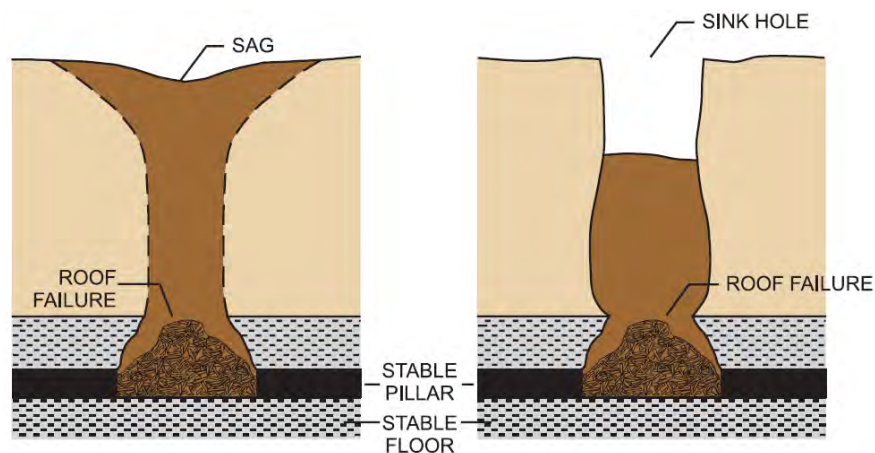

Figure 9.2.1 Roof Failure above Mine Room (Marino Engineering Associates)

### 9.2.2 PILLAR CRUSHING

When the pillar can no longer support the weight, it may crumble, leaving material in place, but with no structural integrity. This causes the remaining load to be redistributed among the intact pillars. May express itself on the surface as a sag, as shown in Figure 9.2.2.



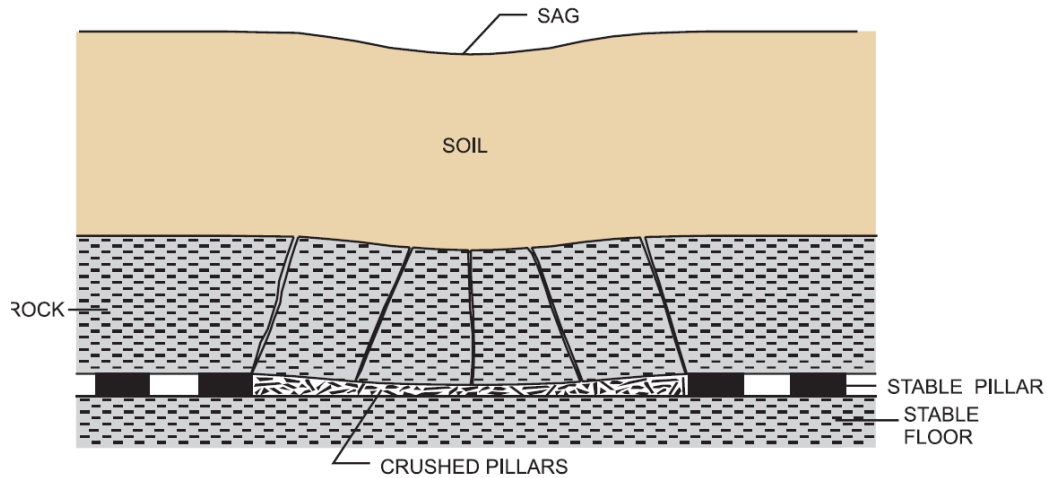

Figure 9.2.2 Pillar Crushing Failure (Marino Engineering Associates)

### 9.2.3 FLOOR YIELDING FAILURE

When the floor strata yields – usually due to weakening of the material due to water. This will lead to the floor around the pillars to heave, as the pillars move vertically downward into the weakened strata. Also called “Pillar Punching”, this may express itself on the surface as a sag, as shown in Figure 9.2.3.

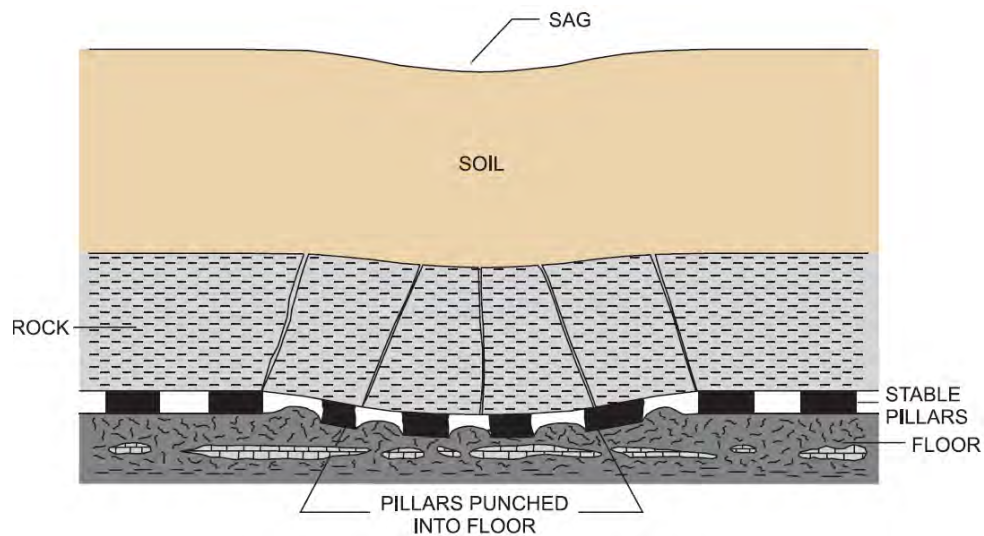

Figure 9.2.3 Floor Yielding Failure (Marino Engineering Associates)

### 9.2.4 ROOF AND FLOOR GEOLOGY CHANGES

Intersections between different strata can cause the roof in the mine rooms to fail along faults and bedding planes, causing roof material to fall into the opening, or floor yielding failures (Figures 9.2.4 and 9.2.5).

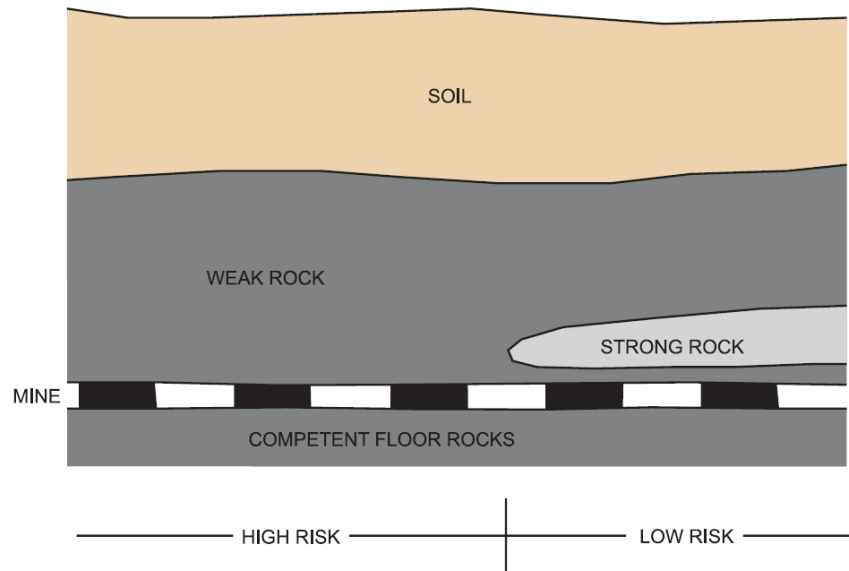

Figure 9.2.4 Changing Roof Geology and Failure Risk Zones (Marino Engineering Associates)

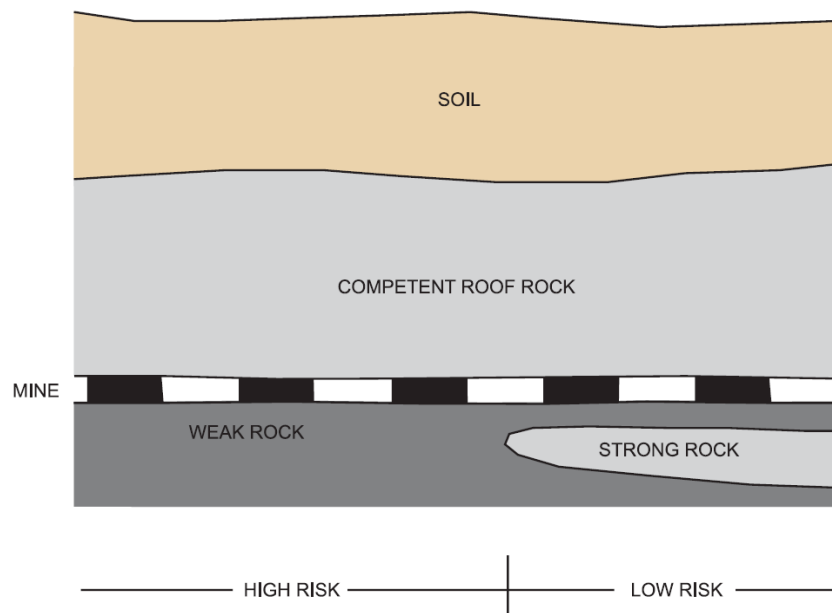

Figure 9.2.5 Changing Floor Geology and Failure Risk Zones (Marino Engineering Associates)

### 9.3 OVERVIEW OF PILLAR DESIGN TERMS

The design of mine pillars involves the determination of proper sizes of pillars comparable with the expected load and the in-situ strength of the coal strata. Before we discuss the different methods used to design the optimum pillar size and layout, we will cover the different terms used. The following terms are commonly used to describe the geometry of pillar layouts and openings in underground coal mines (Figures 9.1 and 9.2).

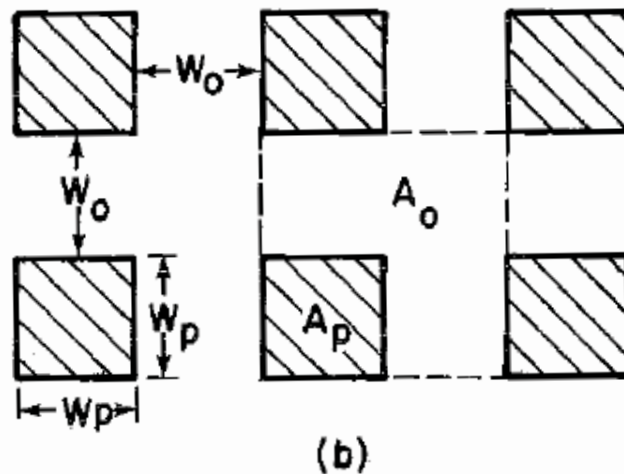
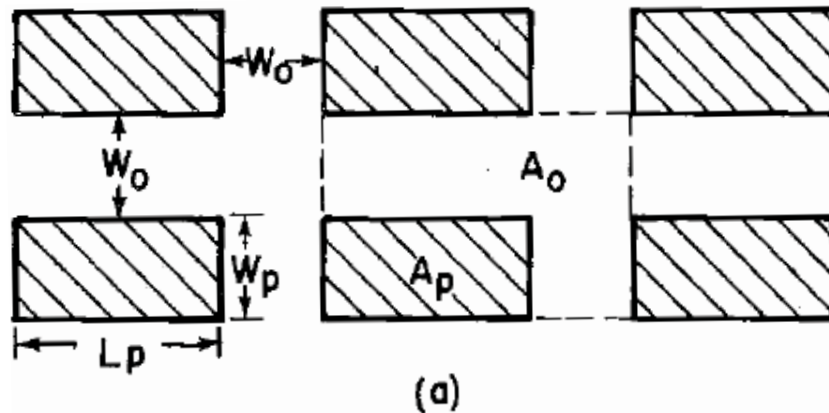

Figure 9.3 Arrays of rectangular and square pillars with symbols (Hustrulid 1982)

- Areal Extraction Ratio ( $R_a$ )  
The ratio between the area of the opening to the total area, or  $A_o/(A_o+A_p) = A_o/A_t$
- Average Pillar Stress ( $S_p$ ) or Pillar Load  
The stress applied to the pillars in a coal seam after mining has removed some of the support.
- In Situ/Critical Coal Strength ( $\sigma_1$ )  
Strength of a given cube of coal as tested in the laboratory, taken as the in-situ strength of the coal
- Depth below surface ( $H$ )  
Depth of the coal seam, or thickness of overburden
- Mining Recovery ( $R$ )  
The percentage of coal removed during mining.
- Opening Area ( $A_o$ ) or Mined Area ( $A_m$ )

- The area of opening/mining that is left unsupported.
- Opening Width ( $W_o$  or B)
  - The mined-out width between the pillars, also called the room width.
- Pillar Area ( $A_p$ )
  - The area of the coal pillar, for square  $W_p \times W_p$ , or for rectangular  $W_p \times L_p$ .
- Pillar Length ( $L_p$ )
  - The length of the pillar, for square, equal to  $W_p$ , for rectangular, will be a separate dimension.
- Pillar Strength ( $\sigma_p$ )
  - Pillar strength as calculated by an equation
- Pillar Width ( $W_p$ )
  - The width of the pillar - if the pillars are square, this is usually both the width and length designation.
- Total Area ( $A_t$ )
  - The total area supported by a pillar, or  $A_p + A_o$
- Uniaxial Compressive Strength of Coal Specimen ( $\sigma_c$  or  $\sigma_{cube}$ )
  - Strength of a given cube of coal as tested in the laboratory, taken as the in-situ strength of the coal
- Vertical Applied Stress ( $S_v$ )
  - The total stress applied to the seam prior to mining.

## 9.4 IMPORTANT CALCULATIONS FOR PILLAR DESIGN

Before discussing the methods used for pillar design in regards to sizing, other calculations are often necessary or helpful to do prior to a more involved evaluation. For example, the percent recovery (or amount of coal recovered during the mining process) can often give an idea as to whether or not an area will be prone to unplanned subsidence.

### 9.4.1 PERCENT RECOVERY

To calculate the percent of recovery during coal mining, the following equation can be used:

$$R = \left( \frac{A_t - A_p}{A_t} \right) \times 100 = \frac{A_m}{A_t} \times 100$$

Example problem:

- Entry Width (B) 20 ft
- Pillar Size 70 ft x 70 ft center to center

Note that the Pillar dimensions are actually 50 ft x 50 ft, once the entry width is subtracted.

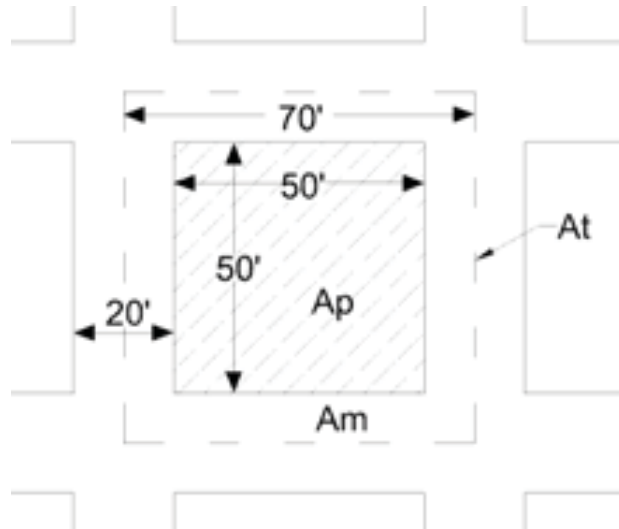

$$R = \left( \frac{(50ft + 20ft)^2 - (50ft)^2}{(50ft + 20ft)^2} \right) \times 100 = \frac{(4900ft^2 - 2500ft^2)}{4900ft^2} \times 100$$

$$= \frac{2400ft^2}{4900ft^2} \times 100 = 48.98\%$$

#### 9.4.2 PILLAR LOAD

To calculate the percent of recovery during coal mining, the following equation can be used:

$$Pillar\ Load\ (S_p) = \frac{1.1 \times H}{1 - R}$$

- Note: This equation assumes a unit weight of the overburden as approximately 160 lb/cubic ft, which equates to 1.1 psi/ft of depth
- Entry Width (B) 20 ft
- Pillar Size 70 ft x 70 ft center to center
- Mining Depth (H) 500 ft

Note that the Pillar dimensions are actually 50 ft x 50 ft, once the entry width is subtracted.

$$Pillar\ Load\ (S_p) = \frac{1.1\ psi / ft\ depth \times H}{1 - R} = \frac{1.1 \times 500\ ft}{1 - 0.4898} = \frac{550\ ft}{0.5102} = 1,078\ psi$$

#### 9.5 PILLAR DESIGN EQUATIONS

Pillar design and stability analysis for coal mines has been studied since Vicat, in 1833,

provided a simple equation for the strength of a rectangular shaped specimen that was loaded in compression. In 1867, Bauschinger produced pillar design equations that assembled much of the work that had been completed to that time. In 1911, Bunting, utilizing the tributary area method, was the first to indicate that the pillar size should be increased proportionately with the depth of mining and the thickness of the coal seam (Babcock 1994).

Since then, lots of research has produced a variety of pillar strength equations, which we will now discuss. Most equations focus on determining the strength of a given pillar configuration. This calculated strength is then used to compute the Factor of Safety for that pillar design (also called the “Stability Factor”). Each equation comes with a recommended factor of safety for use in design of pillars. Typically, these range from 1.5-2.0, but will be discussed with each equation more specifically.

### 9.5.1 HOLLAND

Professor Holland was a pioneer in the field of rock mechanics relative to coal mine design with his most significant contributions in the domain of concepts explaining coal bumps or bursts. He was a professor and/or dean at Virginia Polytechnic Institute and State University (Virginia Tech) and at West Virginia University. His research work on coal pillar strength spanned from the 1940s and went through several iterations until his final formula was published in 1973 (Babcock 1994):

$$\sigma_p = \sigma_{cube} \sqrt{\frac{w}{h}}$$

### 9.5.2 HOLLAND-GADDY

Professor Holland also worked with Frank Gaddy at Virginia Tech in the midst of his formula development, culminating in a modified formula referred to as the Holland-Gaddy and published in 1964 (Iannacchione 1992):

$$\sigma_p = k \frac{\sqrt{w}}{h}$$

$$k = \sigma_{cube} \sqrt{D}$$

### 9.5.3 BIENIAWSKI

Extensive in situ tests were performed on coal in South Africa during 1966-1973 as a response to a mine disaster at the Coalbrook Mine where 427 miners lost their lives in 1960 due to pillar collapse. This equation is applicable to square mine pillars, and work was further done (see next section) with Dr. Mark to expand the applicability for this formula to rectangular pillars:

$$\sigma_p = \sigma_1 \left( 0.64 + 0.36 \frac{w}{h} \right)$$

To determine an appropriate “safety factor” or “stability factor” for the Bieniawski equation, 174 case studies from the United States were evaluated in 1982. Based on

this evaluation, the following values were determined to be appropriate for use in coal mines in the United States (Iannacchione 1992):

Room and Pillar Mining		
	Nonretreating Panels	1.5
	Retreat Panels	2.0
	Mains	2.0
	Barrier Pillars	2.5
Longwall Mining		
	Tailgate Chain Pillars	1.3
	Pillars in Bleeder Entries	1.5 to 2.0
	Mains	2.0
	Barrier Pillars	2.5

#### 9.5.4 MARK-BIENIAWSKI

A modified version of the Bieniawski formula was developed using the same empirical stress gradient to extend the classic pillar strength formula to rectangular pillars.

$$\sigma_p = \sigma_1 \left( 0.64 + 0.54 \left( \frac{W}{h} \right) - 0.18 \left( \frac{W^2}{lh} \right) \right)$$

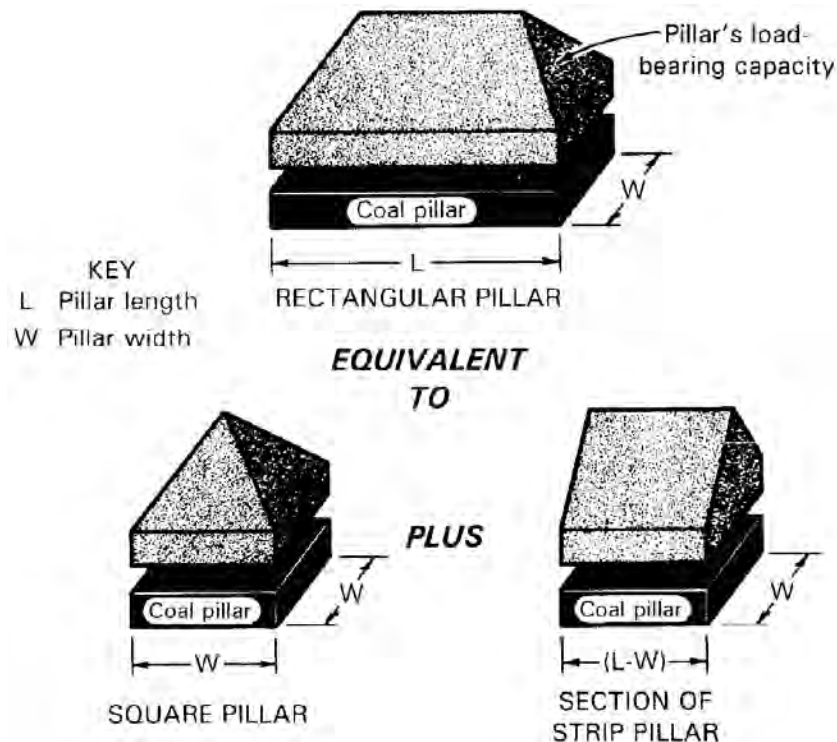

Figure 9.4 Conceptual depiction of the Mark-Bieniawski pillar strength formula (from Mark and Chase 1997)

### 9.5.5 WILSON

Wilson favors the progressive failure concept for pillar design, where as time passes, the outer abutment zone of a pillar progressively fails. Pillar strength is calculated from the mechanical properties of the coal and surrounding rock, requiring extensive testing to obtain the correct values.

$$y = m \int_{\sigma_c}^{\sigma_{max}} \frac{d \sigma_c}{\tau_r + \tau_f} d \sigma_v$$

### 9.5.6 SALAMON-MUNRO

Developed in South Africa using back analysis of previous experience with mine pillar performance (not widely used in the US):

$$\sigma_p = 1,320 \text{ psi} \left( \frac{w^{0.46}}{h^{0.66}} \right)$$

### 9.5.7 OBERT-DUVALL

Derived for hard-rock mining, not used in the US coal industry:

$$\sigma_p = \sigma_{cube} \left( 0.778 + 0.222 \left( \frac{w}{h} \right) \right)$$

### 9.5.8 ACCEPTED SAFETY FACTORS FROM EACH EQUATION

Each pillar design equation has suggested acceptable safety factors for use in applying those equations:

#### 9.5.8.1 HOLLAND

- Stable Pillars: 1.8
- Width-to-Height Pillar Ratio 10:1
  - Pillars in bleeder entries 1.5 – 2.0
  - Mains 2.0
  - Barrier pillars 2.5

#### 9.5.8.2 HOLLAND-GADDY

- Valid for width-to-height ratios: 2 – 8
- Recommended Safety Factor: 1.8 – 2.2
- Average Safety Factor: 2.0

#### 9.5.8.3 BIENIAWSKI

- Valid for width-to-height ratios up to 5
- Room-and-Pillar Mining
  - Nonretreating panels 1.5
  - Retreating panels 2.0
  - Mains 2.0



- Pillars 2.5
- Longwall Mining
  - Tailgate chain pillars 1.3
  - Pillars in bleeder entries 1.5 – 2.0
  - Mains 2.0
  - Barrier pillars 2.5

#### 9.5.8.4 MARK-BIENIAWSKI

- Valid for width-to-height ratios up to 5
- Less than 750 ft of cover: 1.5
- Greater than 1250 ft of cover: 0.9

#### 9.5.8.5 WILSON

- 2.0

#### 9.5.9 COMPARED CALCULATED VALUES FROM EACH EQUATION

In order to demonstrate the values that each of the pillar design equations will give in the same scenario, we will now calculate the strength of each pillar and the corresponding safety factor for the following coal mine set-up:

- Mining Height (h) 5 ft
- Mining Depth (H) 500 ft
- Entry Width (B) 20 ft
- Pillar Size 70 ft x 70 ft center to center
- In-situ coal strength ( $\sigma_{cube}$  or  $\sigma_1$ ) 900 lbs per square inch (psi)
- Average overburden weight 160 lbs per cubic foot (pcf)

Note that the Pillar dimensions are actually 50 ft x 50 ft, once the entry width is subtracted.

#### HOLLAND FORMULA

$$\sigma_p = \sigma_{cube} \sqrt{\frac{w}{h}}$$

$$\sigma_p = 900 \text{ psi} \sqrt{\frac{50 \text{ ft}}{5 \text{ ft}}}$$

$$\sigma_p = 900 \text{ psi} \times \sqrt{10} = 900 \text{ psi} \times 3.1623 = 2,846.05 \text{ psi}$$

#### HOLLAND-GADDY FORMULA

$$k = \sigma_{cube} \sqrt{D}$$

$$k = 900 \text{ psi} \times \sqrt{3 \text{ in}} = 900 \text{ psi} \times 1.732 = 1,558.85$$

$$\sigma_p = k \frac{\sqrt{w}}{h}$$

$$\sigma_p = 1,558.85 \times \frac{\sqrt{50ft}}{5ft}$$

$$\sigma_p = 1,558.85 \times \left(\frac{7.07}{5}\right) = 1,558.85 \times 1.414 = 2,204.55psi$$

### **BIENIAWSKI FORMULA**

$$\sigma_p = \sigma_1 \left(0.64 + 0.36 \frac{w}{h}\right)$$

$$\sigma_p = 900 psi \left(0.64 + 0.36 \left(\frac{50}{5}\right)\right) = 900 psi(0.64 + 3.6) = 900psi \times 4.24 = 3,816 psi$$

### **MARK-BIENIAWSKI FORMULA**

Will be the same as the Bieniawski Formula above – due to square pillars.

### **SALAMON-MUNRO FORMULA**

$$\sigma_p = 1,320 psi \left(\frac{w^{0.46}}{h^{0.66}}\right)$$

$$\sigma_p = 1,320 psi \left(\frac{50^{0.46}}{5^{0.66}}\right) = 1,320 psi \times \left(\frac{6.047}{2.893}\right) = 1,320 psi \times (2.09) = 2,758.80 psi$$

### **OBERT-DUVALL FORMULA**

$$\sigma_p = \sigma_{cube} \left(0.778 + 0.222 \left(\frac{w}{h}\right)\right)$$

$$\sigma_p = 900 psi \left(0.778 + 0.222 \left(\frac{50}{5}\right)\right) = 900 psi \times (0.778 + 2.22)$$

$$= 900 psi \times (2.998) = 2,698.20 psi$$

### **SAFETY FACTOR COMPARISONS**

Givens for example problem:

- Mining Height (h) 5 ft
- Mining Depth (H) 500 ft
- Entry Width (B) 20 ft
- Pillar Size 70 ft x 70 ft center to center
- In-situ coal strength ( $\sigma_{cube}$  or  $\sigma_1$ ) 900 lbs per square inch (psi)

Calculated values from example problem:

- Width-to-Height Ratio                      50:5 or 10
- Pillar Load ( $S_p$ )                              1,078 psi

$$Safety\ Factor = \frac{\sigma_p}{S_p} = \frac{\sigma_p}{1,078\ psi}$$

Equation	Calculated Strength $\sigma_p$ (psi)	Safety Factor
Holland	2,846.05	2.64
Holland-Gaddy	2,204.55	2.05
Bieniawski	3,816.00	3.54
Mark-Bieniawski	Same as Bieniawski	
Wilson	Not Done	
Salamon-Munro	2,758.80	2.56
Obert-Duvall	2,698.20	2.50

### 9.6 USING SDPS SOFTWARE FOR PILLAR DESIGN

The Surface Deformation Prediction System was developed by Virginia Tech and sponsored by OSMRE funding. This means that OSMRE and our customers (SMCRA personnel) can obtain the software through our TIPS program, so if you are interested, please contact your Service Manager. (The software is commercially available through Carlson Software.)

There are several modules within the software, and we will use the Pillar Stability Analysis module in this chapter.

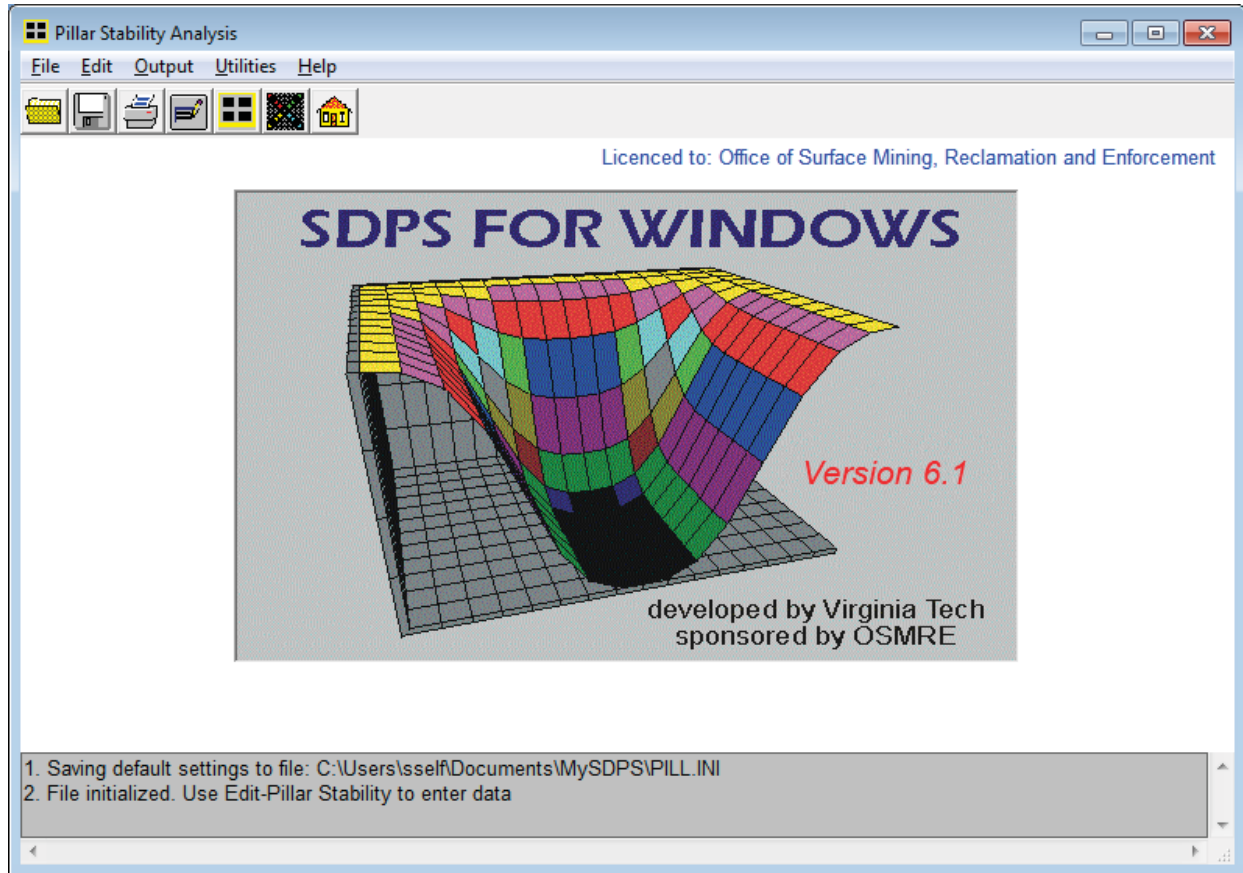

Once the program is initialized, go to the **Edit** pull-down menu, to **Pillar Stability, Standard Geometry**. This brings up the **Pillar Stability Parameters - Standard Geometry** dialog box. Input the given values, and press the **Results** button - will bring up the **Calculation Results: Standard Geometry** dialog.

Pillar Stability Parameters - Standard Geometry

**Pillar Geometry** | Pillar Strength | Pillar Sizing

Average Unit Weight of Overburden (pcf)

Average Overburden Depth (ft)

Pillar Width (ft)

Pillar Length (ft)

Pillar Height (ft)

Opening Width (ft)

Average Extraction Ratio (%)

Calculated Extraction Ratio (%)

Use Calculated Ratio if Average is 0

Results | View Plan | Help | Cancel | OK

Calculation Results: Standard Geometry

[SAFETY FACTOR CALCULATIONS]

Formulation	Pillar Strength (psi)	Pillar Stress (psi)	Safety Factor
Bieniawski	3816.00	1102.50	3.46
Holland	2846.05	1102.50	2.58
Holland - Gaddy	2204.54	1102.50	2.00
Obert - Duvall	2698.20	1102.50	2.45
Mark/Bieniawski	3816.00	1102.50	3.46

Previous Page | Next Page | Print Page | Copy Page | Help

View Plot | Print All | Copy All | Close

## 9.7 STATE-SPECIFIC PILLAR DESIGN

Some states have specific guidelines or rules for the design of pillars for underground coal mines. These guidelines may dictate what equation needs to be use and what safety factor should be achieved for pillar stability and permit approval. Others can assist the mine designer in protecting surface structures and infrastructure.

### 9.7.1 KENTUCKY

The Reclamation Advisory Memoranda Number 107 document (included with your course materials) require the use of the Bieniawski or Holland-Gaddy equations for pillar design, and require different values for different categories of structures.

#### 9.7.1.1 CATEGORIES

- Category 1
  - water and sewer lines four (4) inches in diameter or less;
  - exposed oil and gas collector pipelines less than six (6) inches in diameter; and
  - electric lines and telephone lines to single family dwellings, livestock buildings, or
  - other domestic structures.
- Category 2
  - public roads not identified in Category 3;
  - single poles for electric transmission or telephone lines;
  - buried oil and gas collector pipelines less than six (6) inches in diameter; and
  - mobile homes.
- Category 3
  - oil and gas non-collector pipelines less than six (6) inches in diameter;
  - oil pipelines six (6) inches in diameter or greater;
  - water lines greater than four (4) inches in diameter;
  - impoundments having a storage volume twenty (20) acre feet or more not identified in Category 4;
  - reservoirs serving as public water supplies;
  - aquifers serving as public water supplies;
  - multi-leg structures for electric transmission lines or telecommunications;
  - perennial streams;
  - dwellings that are occupied or reasonably subject to habitation;
  - state and federal roads; and

- commercial/industrial buildings.
- Category 4
  - hospitals, schools, churches, and publicly owned buildings;
  - gas pipelines six (6) inches in diameter or greater;
  - dams classified as Class B or Class C impoundments; and
  - state and federal highway bridges.

**9.7.1.2 TABLE OF VALUES ACCEPTED**

Equation	Category 1	Category 2	Category 3	Category 4
Holland-Gaddy	Narrative	1.8	2.0	2.5
Bieniawski	Narrative	1.5	1.75	2.3

“The narrative for Category 1 must describe how the proposed mining plan will not cause material damage or diminution of value of foreseeable use of the structure” (KY RAM 107).

**9.7.2 PENNSYLVANIA**

Two main resources are used in Pennsylvania for pillar design and subsidence control. These require the Bieniawski equation to be used in underground mine design to achieve a safety factor of 2.0 or higher. They also provide guidance for a protection area design to be left in the mine design to safeguard structures from planned mine subsidence by requiring at least 50% of the coal to remain in a calculated area in the mine.

**9.7.2.1 Technical Review, Mine Stability (Document Number 563-211-654)**

Released in July 1997, it sets the Bieniawski equation as the required method for calculating the safety factor for underground coal mine pillars. A value of 2.0 or higher is acceptable using an assumed coal strength of 900 pounds per square inch.

**9.7.2.2 1967 Mine Subsidence Law**

Established the Mine Subsidence Insurance Program, and included Performance Standards that set forth certain limits and guidance for underground coal mine design in Pennsylvania.

**§89.143 Performance Standards**

- (a) *General requirements.* Underground mining activities shall be planned and conducted in accordance with the following:

- (1) The subsidence control plan required by § 89.141(d) (relating to application requirements) and be consistent with the postmining land use protected by § 89.88 (relating to postmining land use).
- (2) The performance standards in subsections (b)-(f).
- (3) No underground mining activity will be authorized beneath structures where the depth of overburden is less than 100 feet, with the exception of mine related openings to the surface such as entries, shafts and boreholes and site specific variances for entry development as approved by the Department.
- (4) The mine operator shall adopt and describe to the Department in his permit application measures to maximize mine stability; however, this subsection does not prohibit planned subsidence in a predictable and controlled manner or the standard method of room and pillar mining.

(b) *Prevention of damage.* Requirements are as follows:

- (1) Underground mining activities shall be planned and conducted in a manner which prevents subsidence damage to the following:
  - (i) Public buildings and noncommercial structures customarily used by the public, including churches, schools and hospitals.
  - (ii) Dwellings, cemeteries, municipal public service operations and municipal utilities, in place on April 27, 1966.
  - (iii) (ii) Impoundments and other bodies of water with a storage capacity of 20 acre feet or more.
  - (iv) (iii) Aquifers, perennial streams and bodies of water which serve as a significant source for a public water supply system, as defined in the Pennsylvania Safe Drinking Water Act (35 P. S. §§ 721.1-721.17).
  - (v) (iv) Coal refuse disposal areas authorized by permits issued under Chapter 90 (relating to coal refuse disposal).
- (2) The damage prohibited by this subsection includes the cracking of walls, foundations and monuments, the draining of aquifers, perennial streams or other bodies of water which serve as a significant source for a public water supply system, as defined in the Pennsylvania Safe Drinking Water Act and the weakening of impoundments and embankments. Damage to structures



described in paragraph (1)(i) and (ii) need not be prevented if done with the consent of the current owner.

(3) The measures adopted to comply with this subsection shall consist of one of the measures in subparagraph (i) or (ii).

(i) The support area beneath the structure or surface feature to be protected where coal extraction is limited to 50%, and the following:

(A) The support area shall consist of pillars of coal of a size and in a pattern which maximizes bearing strength and is approved by the Department.

(B) The support area shall be rectangular in shape and determined by projecting a 15° angle of draw from the surface to the coal seam beginning 15 feet from either side of the structure. For a structure on a slope of 5% or greater, the support area on the downslope side of the structure shall be extended an additional distance determined by multiplying the depth of the overburden by the percentage of the surface slope. A pillar lying partially within the support area shall be considered part of the support area and be consistent with the other support pillars in size and pattern.

(C) The area between the two support areas shall be treated as a support area, when the distance between the two support areas is less than the depth of the overburden.

(D) More stringent measures may be imposed or mining may be prohibited, if the measures fail to prevent subsidence damage.

(ii) Alternative measures, including full extraction techniques which result in planned and controlled subsidence, may be adopted where the operator demonstrates that the proposed measures are at least as effective in the prevention of subsidence damage as those described in this subsection. In support of the demonstration the Department may require:

(A) Premining and postmining elevation surveys of a nearby area which core samples demonstrate to be geologically similar to the area of the protected surface features.

(B) A history of mining in the surrounding area and a report listing claims of subsidence damage resulting from the mining.

(C) An engineering report on the damage to be expected from the

proposed mining pattern.

- (D) The operator to initiate a monitoring program to detect surface movement resulting from the mining operation. The program shall consist of monitors placed sufficiently in advance of the mining so that the mining can be stopped before the protected surface features are damaged; in calculating this distance a 25° angle of draw shall be used.

**9.7.2.3 Example Problem - Determining the Size needed for Support Area using the Pennsylvania Guidelines**

Use the Pennsylvania guidelines and determine the 50% recovery support area. Calculate the length and width of the support area using the given information.

Given for example problem:

- Mining Depth (H) 400 ft
- Entry Width (L x W) 40 ft x 35 ft
- Surface Slope less than 5%
- Constant "Safety" Zone 15 ft

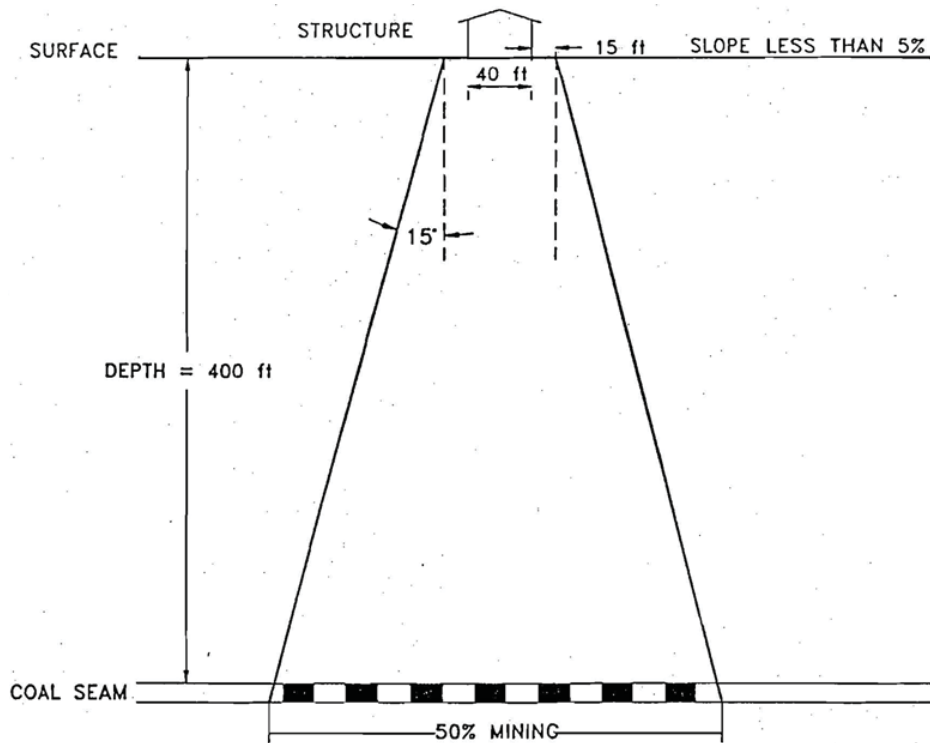

$$\begin{aligned} \text{Length of the Support Area} &= 2 \times [(\tan 15^\circ \times H) + 15 \text{ ft}] + L \\ &= 2 \times [(0.267949 \times 400 \text{ ft}) + 15 \text{ ft}] + 40 \text{ ft} \\ &= 2 \times [(107.2 \text{ ft}) + 15 \text{ ft}] + 40 \text{ ft} = 2 \times [122.2 \text{ ft}] + 40 \text{ ft} \\ &= \mathbf{284.4 \text{ ft}} \end{aligned}$$

$$\begin{aligned} \text{Width of the Support Area} &= 2 \times [(\tan 15^\circ \times L) + 15 \text{ ft}] + L \\ &= 2 \times [(0.267949 \times 400 \text{ ft}) + 15 \text{ ft}] + 35 \text{ ft} \\ &= 2 \times [(107.2 \text{ ft}) + 15 \text{ ft}] + 35 \text{ ft} = 2 \times [122.2 \text{ ft}] + 40 \text{ ft} \\ &= \mathbf{279.4 \text{ ft}} \end{aligned}$$

## References, Chapter 9

Babcock, C. 1994. *Bureau of Mines Information Circular 9398: Critique of Pillar Design Equations from 1833 to 1990*. U.S. Bureau of Mines.

Darling, P. (Ed.) 2011. *SME Mining Engineering Handbook, 3<sup>rd</sup> Edition*. Denver, CO. Society for Mining, Metallurgy, and Exploration, Inc.

Tien, J.C. *Chapter 13.2 – Room-and-Pillar Mining in Coal*.

Du, X. *Coal Pillar Design Formulae Review and Analysis*. Proceedings of the 27th International Conference on Ground Control in Mining. Morgantown, WV.

Hustrulid, W. A. (Ed.). 1982. *Underground Mining Methods Handbook*. New York: Society of Mining Engineers.

Iannacchione, A.T. et al. 1992. *Information Circular 9315: Proceedings of the Workshop on Coal Pillar Mechanics and Design*. U.S. Bureau of Mines.

Kentucky Department for Surface Mining Reclamation and Enforcement. 1992. *Reclamation Advisory Memoranda #107: Subsidence Control*.

Marino Engineering Associates, Inc. *Engineering Update Issue 14: Establishing Mine Subsidence Risk*.

Mark, C. 1990. *Information Circular 9247: Pillar Design Methods for Longwall Mining*. U.S. Bureau of Mines.

Mark, C. 2006. *The Evolution of Intelligent Pillar Design: 1981-2006*. Proceedings of the 25th International Ground Control in Mining Conference. Morgantown, WV.

Mark, C. et al. 1999. *NIOSH Information Circular 9448: Proceedings of the Second International Workshop on Coal Pillar Mechanics and Design*. U.S. Department of Health and Human Services, Centers for Disease Control and Prevention, National Institute for Occupational Safety and Health. Pittsburgh, PA.

Mark, C. and Chase, FE. 1997. "Analysis of Retreat Mining Pillar Stability" in *NIOSH Information Circular 9446: Proceedings: New Technology for Ground Control in Retreat Mining*. U.S. Department of Health and Human Services, Centers for Disease Control and Prevention, National Institute for Occupational Safety and Health. Pittsburgh, PA.

OSM Technical Report 596. 1991. *GAI Consultants: Guidance Manual on Subsidence Control*. US Department of Commerce, Springfield, VA.

Scovazzo, V. *Comparison of the Mark-Bieniawski and Wilson Pillar Equations using Site Specific Data*. Proceedings of the 27th International Conference on Ground Control in Mining. Morgantown, WV.

Stefanko, R. 1983. *Coal Mining Technology Theory and Practice*. New York: Society of Mining Engineers.

Tadolini, S.C. and Zhang, P. *The Unpredictable Life Cycle of a Coal Pillar*. Proceedings of the 26th International Conference on Ground Control in Mining. Morgantown, WV.