



Gina Johnson &lt;gina.johnson@wyo.gov&gt;

---

**Fwd: Presby Permitting???**

1 message

---

**William Tillman** <william.tillman@wyo.gov>  
To: Gina Johnson <gina.johnson@wyo.gov>

Thu, May 9, 2013 at 8:12 AM

----- Forwarded message -----

From: **James Brough** <james.brough@wyo.gov>  
Date: Wed, May 8, 2013 at 4:30 PM  
Subject: Fwd: Presby Permitting???  
To: William Tillman <william.tillman@wyo.gov>  
Cc: Rich Cripe <rich.cripe@wyo.gov>, Frank Strong <frank.strong@wyo.gov>, Hannes Stueckler <hannes.stueckler@wyo.gov>, Mark Baron <mark.baron@wyo.gov>

Bill, Frank, Rich,

I told Gene Smith with Park County that I would forward this email to you. I was just told by Mark Baron that the Presby policy has not been revoked.

A big reason why the Wyoming DEQ policy was written developed was because of the NSF/ANSI Standard 40 Certification of the Advanced Enviro-Septic System (Presby) as indicated by a letter dated March 30, 2010. Testing performed in Quebec, Canada was reviewed by NSF and found to meet the performance testing and evaluation requirements of NSF/ANSI Standard 40, and the related Class I effluent quality criteria.

James

----- Forwarded message -----

From: **Gene Smith** <gsmith@parkcounty.us>  
Date: Wed, May 8, 2013 at 3:44 PM  
Subject: Presby Permitting???  
To: James Brough <james.brough@wyo.gov>, Hannes Stueckler <hannes.stueckler@wyo.gov>  
Cc: Jim Stevenson <jim@rockvalesystems.com>

Gentlemen,

I see Section Two and Section Five in the new regulations as a hindrance to the Issuing of Presby Systems. We have a Policy13.41.8 which was released in a Memorandum on June 23, 2011. See attachment for your convenience. Nowhere in this Policy does it mention the need for Wy State Engineer stamp. This added requirement adds additional expense and time to the home owner.

Entity: Gene Smith, Park County

Comment: "I would like to see a statement or section in this chapter that deals with the Presby AES systems and a reference to the fact that the regulations established in the Wyoming Manual for the Design, and Installation must be adhered to."

Response: Within Chapter 25 there is Section 5 entitled "Systems not Specifically Covered by these Standards". Systems such as Presby AES can be proposed and covered by the conditions of this section.

Items c & d below are current designs which have required Wy State Engineer Stamp under the current LCO agreement and these are considered "enhanced systems" . However, it appears if these changes are adopted then as long as these worksheet are followed then the current required stamped permits will be waved. This is a streamlining of the permitting process which I applaud.

(c) A design package for a pressure distribution system is provided online at the Division's website to assist you in submitting a completed application for a properly designed wastewater treatment and disposal system. The worksheet and calculations were prepared by a registered professional engineer employed by the Wyoming Department of Environmental Quality, Water Quality Division. The general design requirements stated in this section are incorporated into the worksheets such that by completing the forms the system will comply with those requirements.

(d) A design package for a sand mound system is provided online at the Division's website to assist you in submitting a completed application for a properly designed wastewater treatment and disposal system. The worksheet and calculations were prepared by a registered professional engineer employed by the Wyoming Department of Environmental Quality, Water Quality Division. The general design requirements stated in this section are incorporated into the worksheets such that by completing the forms the system will comply with those requirements.

We basically have the same steps already in place with Policy 13.41.8 and the Wyoming Design and Installation Manual copyright May 2011 and the revised Installation Manual of March 2012. With requirement of joint review of the Presby Applications I see no reason for this system to fall under Section #5. These application will be reviewed on a case by case basis my a Wy State PE in our local WDEQ Regional office and during that review it can:

1. Approved as designed
2. Approved as long as suggested changes are made.
3. Rejected
4. Be rejected and asked for further justification by a Wy State PE and a new application submitted and stamped. Which would then go though WDEQ Review.

**Please let me hear your thoughts, and feel free to share this with anyone you feel should read this prior To the June meeting.**

Sincerely,

Gene Smith

Small Wastewater Administrator

Park County Courthouse

1002 Sheridan Ave

Cody, Wyoming 82414

Attn: Planning & Zoning Dept.

307-527-8549 fax: 307-527-8515

[gsmith@parkcounty.us](mailto:gsmith@parkcounty.us)

---

**NOTICE: Any information created or obtained in the  
transaction of public business, including email, is considered  
public record and may be disclosed to third parties.**

--  
James S. Brough, P.E.  
Northwest District Engineer  
Water Quality Division

510 Meadowview Drive  
Lander, WY 82520  
[307-335-6961](tel:307-335-6961) (office)  
[307-332-7726](tel:307-332-7726) (fax)  
[james.brough@wyo.gov](mailto:james.brough@wyo.gov)

E-Mail to and from me, in connection with the transaction  
of public business, is subject to the Wyoming Public Records  
Act and may be disclosed to third parties.

--  
William Tillman, P. E.  
Water and Wastewater Section  
Regulatory and Enforcement  
Herschler Building, 4-W  
122 West 25th Street  
Cheyenne, WY 82002  
(307) 777-6941  
(307) 777-6779 (FAX)  
[william.tillman@wyo.gov](mailto:william.tillman@wyo.gov)

"Live like there's no tomorrow. One day you'll be right"

E-Mail to and from me, in connection with the transaction  
of public business, is subject to the Wyoming Public Records  
Act and may be disclosed to third parties.

---

 **Policy13.41.8-Presby.pdf**  
67K

**MEMORANDUM**

TO: Wyoming County Septic System Regulators, DEQ Water & Wastewater Section

FROM: James Brough, Northwest District Engineer

THROUGH: Lou Harmon, Water & Wastewater Section Manager 

DATE: June 23, 2011

SUBJECT: Policy 13.41.8 - Wyoming Department of Environmental Quality's Review of Presby's Advanced Enviro-Septic ("AES") systems

This memorandum has been prepared to inform county septic system regulators that the Wyoming Department of Environmental Quality (WDEQ) will allow the permitting and installation of Presby AES systems which can be described as a 10-inch diameter perforated, multi-layer fabric-wrapped pipe that is installed in a bed of specified sand. DEQ must be involved in the permitting process initially, the counties are still authorized to proceed with their routine permitting. When a delegated county receives an application to install a Presby AES system, the county must submit a written request to DEQ to facilitate a joint review between the delegated county and DEQ. This joint review and permitting process will be in effect for five years from the date of this policy.

DEQ has reviewed the reliability and performance test reports for the Presby AES systems. Both laboratory test results and field grab samples have demonstrated that the Presby AES system can consistently reduce biological oxygen demand (BOD) and total suspended solids (TSS) to less than 30 mg/L each. Presby's design and installation manual requests that the soil loading rate of the AES technology system sand bed will be equivalent to a 50% reduction of a traditional pipe and stone dispersion field. This concurs with EPA's Onsite Wastewater Treatment Systems Manual wherein the loading rate for various soils for treated water meeting 30/30 was increased by two. Wyoming DEQ concurs with 50% reduction of a traditional pipe and stone dispersion field (i.e., area of leach field at the sand and native soil interface) based upon BOD and TSS reductions achieved with the Presby AES systems.

Presby Environmental has requested a variance from Wyoming DEQ's required 4-foot vertical separation between the bottom of the leach field and the seasonal high groundwater level. This variance may be requested on an individual basis with each permit. With the permits that this variance may be granted, DEQ will require the installation of an inspection port to enable the monitoring of the seasonal groundwater level. DEQ wants to emphasize that any leach field that becomes submerged fails to protect groundwater and will likely cease to function properly. When a variance is granted to 4-foot vertical separation, the minimum separation distance between the sand/native soil interface and seasonal high groundwater level must not be less than two (2) feet.

DEQ is aware that the Presby AES system is proposed within at least one subdivision where the subdivision was required to have "enhanced treatment" based upon Chapter 23 Subdivision requirement. Where a DEQ Chapter 23 subdivision review required 'enhanced treatment', a

variance to the 4-foot vertical separation requirement is not permissible. Also, in the event that 'enhanced treatment' was required due to nitrate overloading, the land owner will be required to have at least two shallow groundwater monitoring wells, one up-gradient and the other within 10 feet down gradient of the leach field. Annual sampling for nitrates must be collected and reported for at least three years after the installation of the septic system.



---

**Fwd: Chapter 25 Draft with comments**

1 message

---

**William Tillman** <william.tillman@wyo.gov>  
To: Gina Johnson <gina.johnson@wyo.gov>

Thu, May 16, 2013 at 1:18 PM

----- Forwarded message -----

From: **Marcel Lopez** <marcel.lopez@fremontcountygovernment.org>  
Date: Wed, May 15, 2013 at 11:33 AM  
Subject: Chapter 25 Draft with comments  
To: [bill.tillman@wyo.gov](mailto:bill.tillman@wyo.gov)

Bill I have added my comments to your draft regulations. The comments will open automatically as you get to the page they are on. Also I have attached the specification sheet for the Zoller/Clarus d-box so you can see that the use of flow equalizers is redundant with this box which we see frequently in Fremont County. I do appreciate the simplified language in the draft and think it will help contractors be more willing to read the document. If you have any questions just let me know.



**Marcel Lopez**  
Fremont County Planning  
Small Waste Water Sepcialist

(307) 332-1830 Work  
(307) 330-4010 Mobile  
[marcel.lopez@fremontcountygovern...](mailto:marcel.lopez@fremontcountygovern...)  
Room 360 Court House  
450 N. 2nd St.  
Lander, WY 82520

--  
William Tillman, P. E.  
Water and Wastewater Section  
Regulatory and Enforcement  
Herschler Building, 4-W  
122 West 25th Street  
Cheyenne, WY 82002  
(307) 777-6941  
(307) 777-6779 (FAX)  
[william.tillman@wyo.gov](mailto:william.tillman@wyo.gov)

"Live like there's no tomorrow. One day you'll be right"

E-Mail to and from me, in connection with the transaction of public business, is subject to the Wyoming Public Records Act and may be disclosed to third parties.

---

**2 attachments**

 **Ch25 STRIKE UNDERLINE with comments.pdf**  
429K

 **Clarus d-box.pdf**  
291K

Chapter 25  
SMALL WASTEWATER SYSTEMS

Table of Contents

Section 1.	<del>General Authority</del> .....	25-1
Section 2.	<del>Definitions</del> <u>Objective</u> .....	25-1
Section 3.	<del>Design Flows</del> <u>Definitions</u> .....	25-1
Section 4.	<del>Isolation</del> <u>Design Flows</u> .....	25-4
Section 5.	<del>Site Suitability</del> <u>Systems not Specifically Covered by these Standards</u> .....	25-5
Section 6.	<del>Building Sewer Pipes</del> <u>Site Suitability</u> .....	25-6
Section 7.	Soil Absorption System Sizing .....	25-14
Section 8.	<del>Pretreatment</del> <u>Building Sewer Pipes</u> .....	25-16
Section 9.	<del>Dosing Systems Following Septic Tanks</del> <u>Septic Tanks and Other Treatment Tanks</u> .....	25-16
Section 10.	<del>Subsurface Treatment and Disposal Systems</del> <u>Effluent Distribution Devices</u> ..	25-22
Section 11.	<del>Evapotranspiration Beds</del> <u>Standard Soil Absorption Systems</u> .....	25-23
Section 12.	<del>Holding Tanks</del> <u>Pressure Distribution Systems</u> .....	25-25
Section 13.	<del>Privies</del> <u>Sand Mound Systems</u> .....	25-26
Section 14.	<del>Chemical Toilets</del> <u>Small Wastewater Lagoons</u> .....	25-28
Section 15.	<del>Small Non-discharging Waste Stabilization Ponds</del> <u>Privies</u> .....	25-30
Section 16.	<del>Commercial/Industrial Wastes</del> <u>Greywater Systems</u> .....	25-30
<u>Section 17</u>	<u>Operation and Maintenance</u> .....	25-37
APPENDIX A	<u>Percolation Test Procedure</u> .....	A-1
<u>APPENDIX B.</u>	<u>Land Application of Septage</u> .....	B-1

## CHAPTER 25

## SMALL WASTEWATER SYSTEMS

**Section 1. ~~General~~ Authority.**

This rule is promulgated pursuant to Wyoming Statutes (W.S.) 35-11-101 through 35-11-1701, specifically 35-11-302(a)(iii).

**Section 2. ~~Definitions~~ Objective.**

~~(formerly Section 1) This part Chapter contains the minimum standards for the design and construction of sewerage small wastewater systems, treatment works and disposal systems for domestic wastes and industrial wastes generated by facilities other than specifically covered by other parts of this Chapter which are defined by W.S. 35-11-103(c)(ix). The two thousand (2,000) gallons defined in the statute shall be the average flow of domestic sewage per day.~~

A Wyoming registered professional engineer (PE) will be required when small wastewater systems are proposing to use an Advanced Treatment process, encounter high strength wastewater, or propose a standard soil absorption system when the soil percolation rate is over 60 minutes per inch (mpi).

**Section 3. ~~Design Flows~~ Definitions.**

~~(a) "Absorption system" means a system constructed under the surface of the ground which receives and distributes effluent from a pretreatment device effectively filtering the effluent through soil or media. "Absorption surface" means the interface where treated effluent infiltrates into native or fill soil.~~

~~(b) "Aerobic unit" means a covered, watertight receptacle which receives wastewater. The unit removes settleable solids, floatable material, and a part of soluble organic matter by the use of aerobic biological treatment. "Advanced treatment" means a treatment process that achieves an effluent being discharged to the absorption surface or native soil with a BOD<sub>5</sub> less than or equal to 100 mg/L.~~

~~(c) "Building drain" means the building drain is that part of the lowest piping of a drainage system which receives the discharge from soil, waste and other drainage pipes inside the walls of the building and conveys it to the building sewer beginning two feet (.6m) outside the building wall. "Bed" means a soil treatment and dispersal system where the width is greater than three (3) feet.~~

~~(d) "Building sewer" means the building sewer is that part of the horizontal piping of a drainage system which extends from the end of the building drain and conveys the building drain discharge to the septic tank or other onsite sewage disposal facility. "Bedrock" means geological layers, of which greater than 50 percent by volume consist of unweathered in-place consolidated rock or rock fragments. Bedrock also means weathered in-place rock which cannot be hand augered or penetrated with a knife blade.~~

~~(e) "Domestic sewage" means the liquid and waterborne wastes derived from the ordinary living processes, free from industrial wastes, and of such character as to permit satisfactory disposal without special treatment. "Bedroom" means any room that is or may be used for sleeping.~~



(f) ~~“Dosing system” means the system of tanks, pumps or syphons, and piping located between the septic tank and soil absorption system which is intended to apply a large quantity of settled wastewater to the absorption system in a short period of time.~~ “Blackwater” means water containing fecal matter and/or urine.

(g) ~~“Hydrogeological study” means a study of the occurrence, distribution, quality and movement of the shallowmost groundwater of the site and the potential impact of wastewaters on the groundwater.~~ “Five Day Biochemical Oxygen Demand (BOD<sub>5</sub>)” means a measurement of the dissolve oxygen used by microorganisms in the biochemical oxidation of organic matter during a five (5) day period.

(h) ~~“Impermeable soil” means any soil which has a percolation rate greater than 60 minutes per inch.~~ “Building sewer” means the the pipe which carries wastewater from the building.

(i) ~~“Pump Tank” means a tank in which the dosing pumps or syphons are installed.~~ “Chamber” means a domed open bottom structure that is used in lieu of perforated distribution pipe and gravel media.

(j) “Delegated small wastewater program” means a local governmental entity, delegated by the Administrator, with the authority to administer the provisions of W.S. 35-11-301(a) (iii) for small wastewater systems pursuant to the provisions of W.S. 35-11-304.

(k) “Direct human consumption food crops” are crops consumed directly by humans. These include, but are not limited to fruits, vegetables and grains grown for human consumption.

(l) “Domestic wastewater” means a combination of the liquid or water-carried wastes from residences, business buildings, institutions, and other establishments arising from normal living activities.

(m) “Domestic Septage” means liquid or solid material removed from a waste treatment vessel that has received only wastes from residences, business buildings, institutions, and other establishments arising from normal living activities.

(n) “Dosing tank” means a tank equipped with an automatic siphon or pump designed to discharge effluent on an intermittent basis.

(o) “Effluent” means a liquid flowing out of a septic tank, other treatment vessel or system.

(p) “Effluent filter” means a removable, cleanable device inserted into the outlet piping of a septic tank or other treatment vessel designed to trap solids that would otherwise be transported to the soil absorption system or other downstream treatment components.

(q) “Evapotranspiration” means the combined loss of water from soil by evaporation from the soil or water surface and by transpiration from plants.

(r) “Greywater” means untreated wastewater that has not been contaminated by any toilet discharge, which is unaffected by infectious, contaminated, or unhealthy bodily wastes, and does not present a threat from contamination by unhealthful processing, manufacturing, or operating wastes. “Greywater” includes but is not limited to wastewater from bathtubs, showers, bathroom, washbasins, clothes washing machines (unless soiled diapers are serviced), laundry tubs, and kitchen sinks.

(s) “Grease interceptor” means a device designed to separate fats, oils, and grease from the wastewater.

(t) “Groundwater” means subsurface water that fills available openings in rock or soil materials such that they may be considered water saturated under hydrostatic pressure.

(u) “High groundwater” means seasonally or periodically elevated levels of groundwater.

(v) “High Strength Wastewater” means a wastewater stream with a BOD<sub>5</sub> higher than 200 mg/l.

(w) “Holding Tank” means a watertight receptacle designed to receive and store wastewater.

(x) “Manifold” means a non-perforated pipe that distributes effluent to individual distribution pipes.

(y) “Mound system” means an onsite wastewater system where the bottom of the absorption surface is above the elevation of the existing site grade, and the absorption surface is contained in a mounded fill body above the grade.

(z) “Mulch basin” basin means an excavated area that has been refilled with a highly permeable media, organic and inorganic materials intended to distribute greywater to irrigate vegetation.

(aa) “Percolation Rate” means the time expressed in minutes per inch required for water to seep into saturated soil at a constant rate during a test.

(bb) “Pipe Invert” means the bottom or lowest horizontal point of the internal surface of the pipe.

(cc) “Percolation test” means the method used to measure the percolation rate of water into soil as described in Appendix A.

(dd) “Pressure distribution” means a network of pipes in which effluent is forced through orifices under pressure.

(ee) “Pretreatment” means any technology or combination of technologies that precedes discharge to a soil absorption system or other final treatment unit or process before final dissemination into the receiving environment.

(ff) “Restrictive layer” means a nearly continuous layer that has one or more physical, chemical, or thermal properties that significantly impede the movement of water and air through the soil or that restrict roots or otherwise provide unfavorable root conditions. Examples are bedrock, cemented layers, dense layers, and frozen layers.

(gg) ~~(formerly defined in Section 5(e)(ii))~~ “Saturated Thickness” means the distance between the seasonally high groundwater table and the under-lying impervious layer such as clay, bedrock or soils with significantly lower permeability.

(hh) “Septic tank” means a buried, watertight tank designed and constructed to receive and treat raw wastewater.

(ii) “Service provider” means a person authorized and trained by a system manufacturer or their vendor to operate and maintain any proprietary system which provides advanced treatment.

(jj) “Soil absorption system” means a shallow, covered, excavation made in unsaturated soil into which pretreated wastewater is discharged through distribution piping for application onto absorption surfaces through porous media or manufactured components placed in the excavations.

(kk) “Trench” means an absorption surface with a width of three (3) feet or less.

**Section 4. Isolation Design Flows.**

~~(formerly Section 3) The sewerage system, treatment works and disposal system shall have a minimum absorption area based on the minimum peak design flows listed in Table 1 below. The quantity of wastewater shall be determined by one of the following:~~

- (a) Tables 1 and 2 provided in this section.
- (b) Metered water supply data from the facility.
- (c) Metered water supply data from another facility where similar water demands have been demonstrated.

**Table 1**

**Quantities of Domestic Sewage Flows**

Type of Establishment	Flow (gallons per day per _____)
<b>Residential Units</b>	
Single Family Dwellings	150/bedroom
Multiple Family Dwelling (with laundry capabilities)	150/bedroom
Multiple Family Dwelling (without laundry capabilities)	120/bedroom
Cottages	50/person
Mobile Home Parks	350/home*
<b>Commercial Facilities</b>	
Airports	4/passengers
Bar	3/patron
Bathhouses and swimming pools	10/person
Campgrounds (individual sewer outlets available)	100/site
Campgrounds (service building only)	75/site
Car or truck wash	200/vehicle
Church (no food preparation and/or dishwashing)	5/seat
Church (food preparation and/or dishwashing)	7/seat
Country Club	100/member
Factories	30/employee
Hospital	200/bed
Laundry (self-service)	600/machine or 50/cycle
Motels	80/double bed or 40/single bed
Office building	30/employee
Restaurant (toilet and kitchen wastes)	13/meal

Restaurant (kitchen wastes)	6/meal
Restaurant (additional for bars and lounges)	2/meal
Restaurant (kitchen wastes with disposable service)	2/meal
Rest Home	100/resident
<b>Schools</b> Boarding	100/resident student
Day, without gyms, cafeterias, or showers	15/student
Day, with cafeterias only	20/student
Day, with cafeteria, gym and showers	25/student
Service stations	10/vehicle served
Shopping Center	2/parking space
Store, Retail	30/employee
Theaters: Movie	5/seat
Drive In	15/vehicle space
Warehouses	30/employee

\* Must consider flow into the soil absorption system from mobile homes where taps are allowed to run to prevent freezing.

**Table 1. Residential Design Flow Rates per Bedroom (gallons per day, gpd)<sup>1</sup>**

<a href="#">1 bedroom</a>	<a href="#">150</a>
<a href="#">2 bedrooms</a>	<a href="#">280</a>
<a href="#">3 bedrooms</a>	<a href="#">390</a>
<a href="#">4 bedrooms</a>	<a href="#">470</a>
<a href="#">5 bedrooms</a>	<a href="#">550</a>
<a href="#">6 bedrooms</a>	<a href="#">630</a>

<sup>1</sup>An unfinished basement is considered two (2) additional bedrooms.

<sup>2</sup>The design flow shall be increased by eighty (80) gpd for each additional bedroom over six (6).

**Table 2. Non-Residential Wastewater Design Flow Rates<sup>1</sup>**

Facility	Unit	Flow (gallons/unit/day)
Airports	<a href="#">person</a>	4
<a href="#">Apartment</a>	<a href="#">bedroom</a>	<a href="#">120</a>
<a href="#">Automobile</a> Service Station	vehicle served	10
Bars	<a href="#">seat</a>	<a href="#">20</a>
Bathhouses and swimming pools	person	10
Campgrounds ( <a href="#">w/ toilets only</a> )	<a href="#">person</a>	<a href="#">25</a>
Campgrounds ( <a href="#">w/shower facility</a> )	<a href="#">person</a>	<a href="#">45</a>
<a href="#">Church</a>	<a href="#">person</a>	4

Country Club		member	<u>25</u>
<u>Day School, Office building, Retail Store, Warehouse (no showers)</u>		<u>person</u>	<u>15</u>
Hospital		bed	<u>250</u>
<u>Industrial Building (sanitary waste only)</u>		<u>employee</u>	<u>20</u>
Laundry (self-service)		<u>machine</u>	<u>450</u>
Mobile Home		<u>each</u>	<u>70</u>
Motel, <u>Hotel, Resort</u>		<u>bedroom</u>	<u>140</u>
<u>Recreational Vehicle</u>		<u>each</u>	<u>100</u>
Rest Home, <u>Care Facility, Boarding School</u>		bed	100
Restaurant		meal	<u>10</u>
Theater		<u>seat</u>	<u>3</u>

<sup>1</sup>Values shown in the above table are the typical flowrates from Wastewater Engineering Treatment and Reuse, Metcalf & Eddy, 2003 Edition.

#### **Section 5. ~~Site Suitability~~ Systems not Specifically Covered by this rule.**

This section is provided to encourage new technology and equipment and provide a process for evaluating and permitting designs which deviate from this rule. The proposed construction of facilities and processes not in compliance with this rule will be permitted provided that the facility, when constructed, can operate meeting the purpose of these rules.

(a) Each application for a permit to construct shall include an engineering design report, detailed construction plans, and technical specifications for all piping, tanks, and equipment. All of the documents shall have a suitable title showing the owner's name and the Wyoming registration number, seal, and signature of the engineer.

(b) Each application for a permit to construct will be evaluated on a case-by-case basis using the best available technology. The application shall include at least one of the following:

(i) Data obtained from a full scale, comparable installation which demonstrates the acceptability of the design.

(ii) Data obtained from a pilot plant operated under the design condition for a sufficient length of time to demonstrate the acceptability of the design.

(iii) Data obtained from the theoretical evaluation of the design which demonstrates a reasonable probability of the facility meeting the design objectives.

(iv) An evaluation of the flexibility of making corrective changes to the constructed facility in the event it does not function as planned

(c) If an applicant wishes to construct a pilot plant to provide data necessary to show the design will meet the purpose of the act, a permit to construct must be obtained.

## **Section 6. Building Sewer Pipes Site Suitability.**

~~Formerly 4(e)(a)~~ **Location.** Locate the small wastewater system where the surface drainage is good. Avoid depressions and bases of slopes and areas in the path of runoff from roofs, patios, driveways, or other paved areas unless surface drainage is provided. ~~Absorption systems~~ Small wastewater systems shall not be located beneath buildings, parking lots, roadways, driveways, irrigated landscaping or other similarly compacted areas.

~~(formerly 10(a)(i)(b)~~ **Replacement area.** ~~An area shall be designated and shown on the plans for future installation of a replacement absorption system. The site must be large enough to include area for a future replacement soil absorption system. Both the proposed and replacement soil absorption systems shall be sized to receive one-hundred (100%) percent of the wastewater flow. If a trench system is used, the replacement area soil absorption system may include the area be located between the trenches of the proposed soil absorption system if sufficient spacing has been provided there is at least nine (9) feet of spacing between trench sidewalls. At least three feet of undisturbed soil shall remain between the existing and replacement trench side walls.~~

(c) For standard soil absorption system, effective suitable soil depth shall extend at least four (4) feet below the bottom of the soil absorption system to any restrictive layer or highly permeable material.

~~(formerly 5(e)) (d) ——— Groundwater protection and bedrock or impermeable soil separation. The depth of the high groundwater shall be at least four (4) feet below the bottom of the absorption surface. (formerly 5(e)(ii)) — For all systems other than single family homes up to 2000 gallons per day, the depth to bedrock or impermeable soil must be at least four feet from the natural ground surface. The depth to seasonally high groundwater must be at least four feet from the bottom of the absorption system stone and at least two feet from the natural ground surface. Also, a minimum of three (3) feet of unsaturated soil shall be maintained between the bottom of the absorption system stone surface and the estimated groundwater mound imposed on the seasonally high groundwater table. The height of the groundwater mound may be estimated from Figures 1 through 6. The average daily flow should be used and may be estimated as 0.6 times the flow determined from Tables 1 and 2. In areas of high groundwater, this vertical separation requirement is most commonly satisfied by a mound and pressure dosed soil absorption system.~~

~~(formerly 5(e)(i)) For single family homes, the depth to bedrock or impermeable soil must be at least four feet from the bottom of the absorption system stone and the natural ground surface. The depth to seasonally high groundwater must be at least four feet from the bottom of the absorption system stone and at least two feet from the natural ground surface.~~

~~(formerly 5(e)(iii)) For all systems larger than 2000 gallons per day, a minimum of three feet of unsaturated soil shall be maintained between the bottom of the absorption system stone and the estimated groundwater mound imposed on the seasonally high groundwater table. The maximum height of the groundwater mound shall be estimated by the design engineer.~~

~~(formerly 5 (e)(ii)) “Estimated Rise in Water Table”: The estimated distance the water table will rise at the center of the absorption system above the initial water table when the indicated flow is applied daily.~~

DRAFT

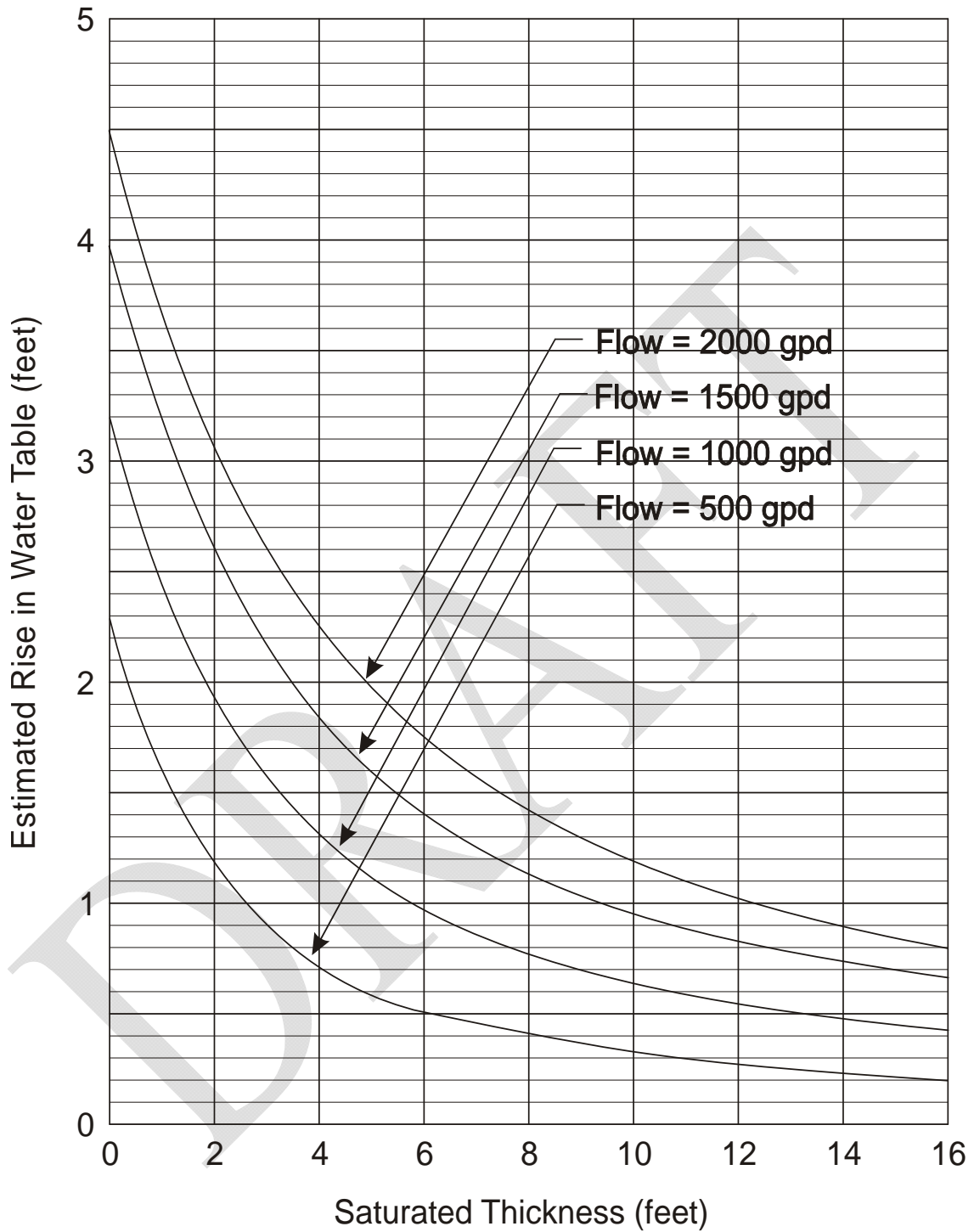

BASED ON A SOIL PERCOLATION RATE = 10 min/inch

FIGURE 1



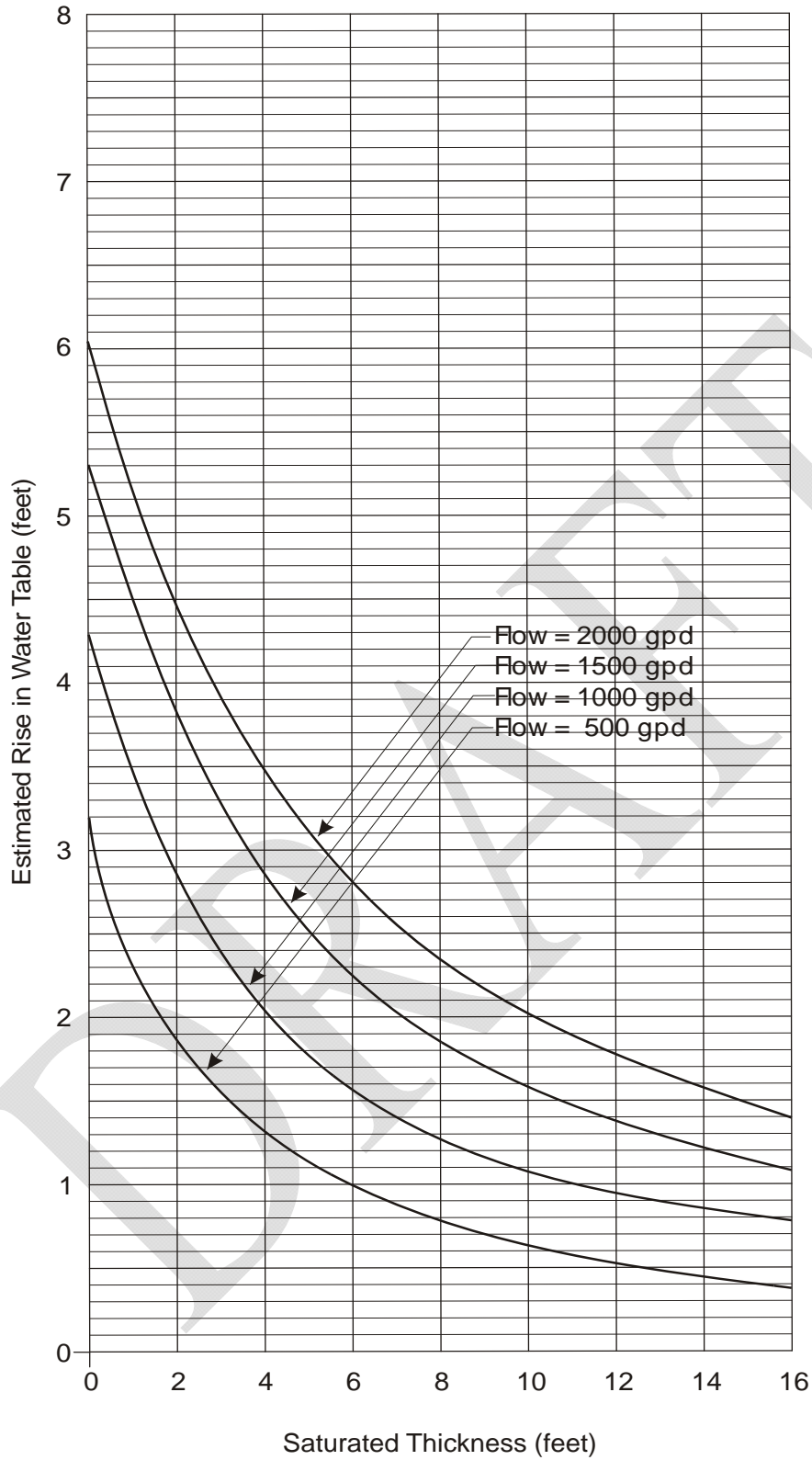

BASED ON A SOIL PERCOLATION RATE = 20 min/inch

FIGURE 2

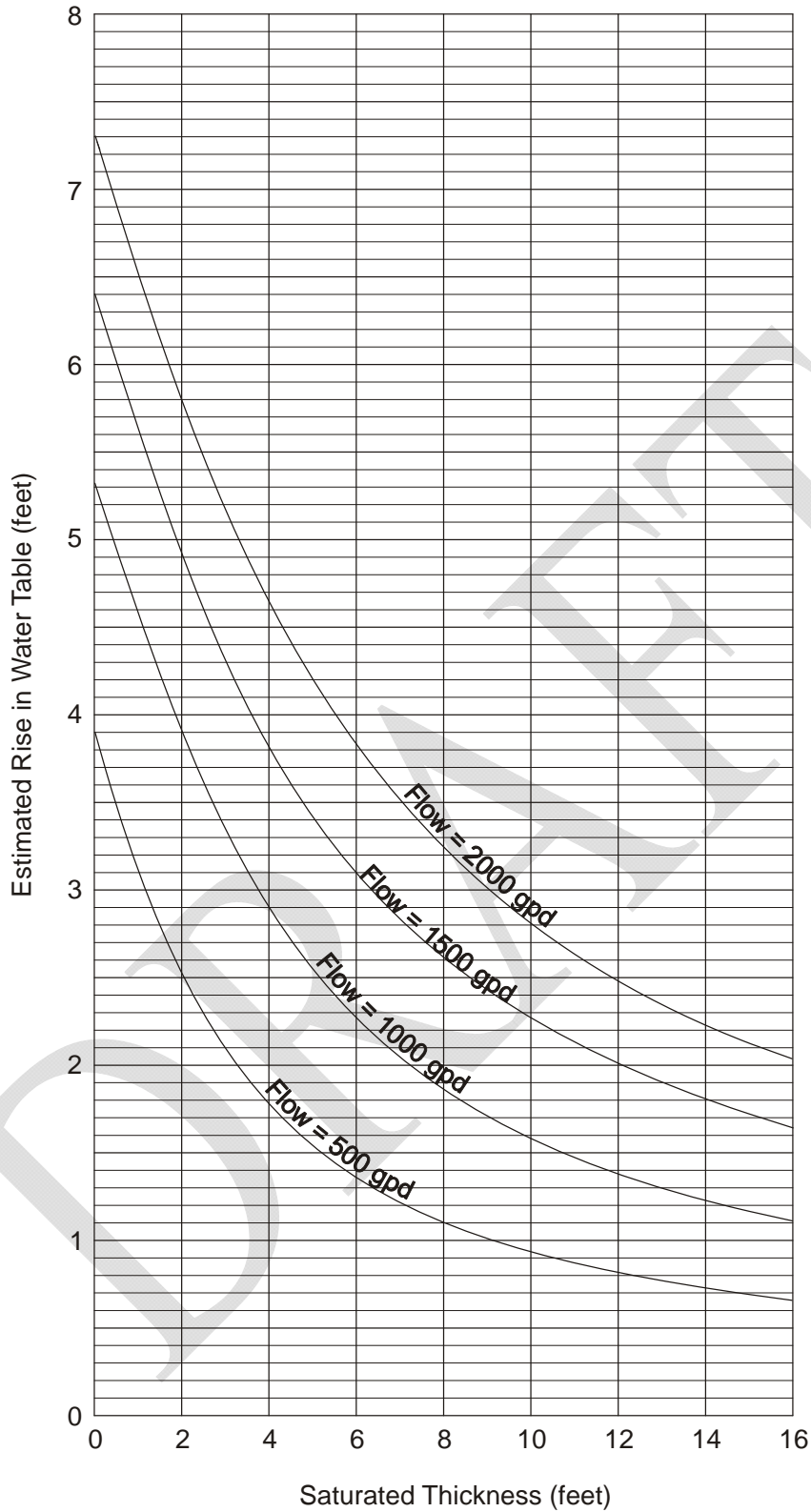

BASED ON A SOIL PERCOLATION RATE = 30 min/inch

FIGURE 3

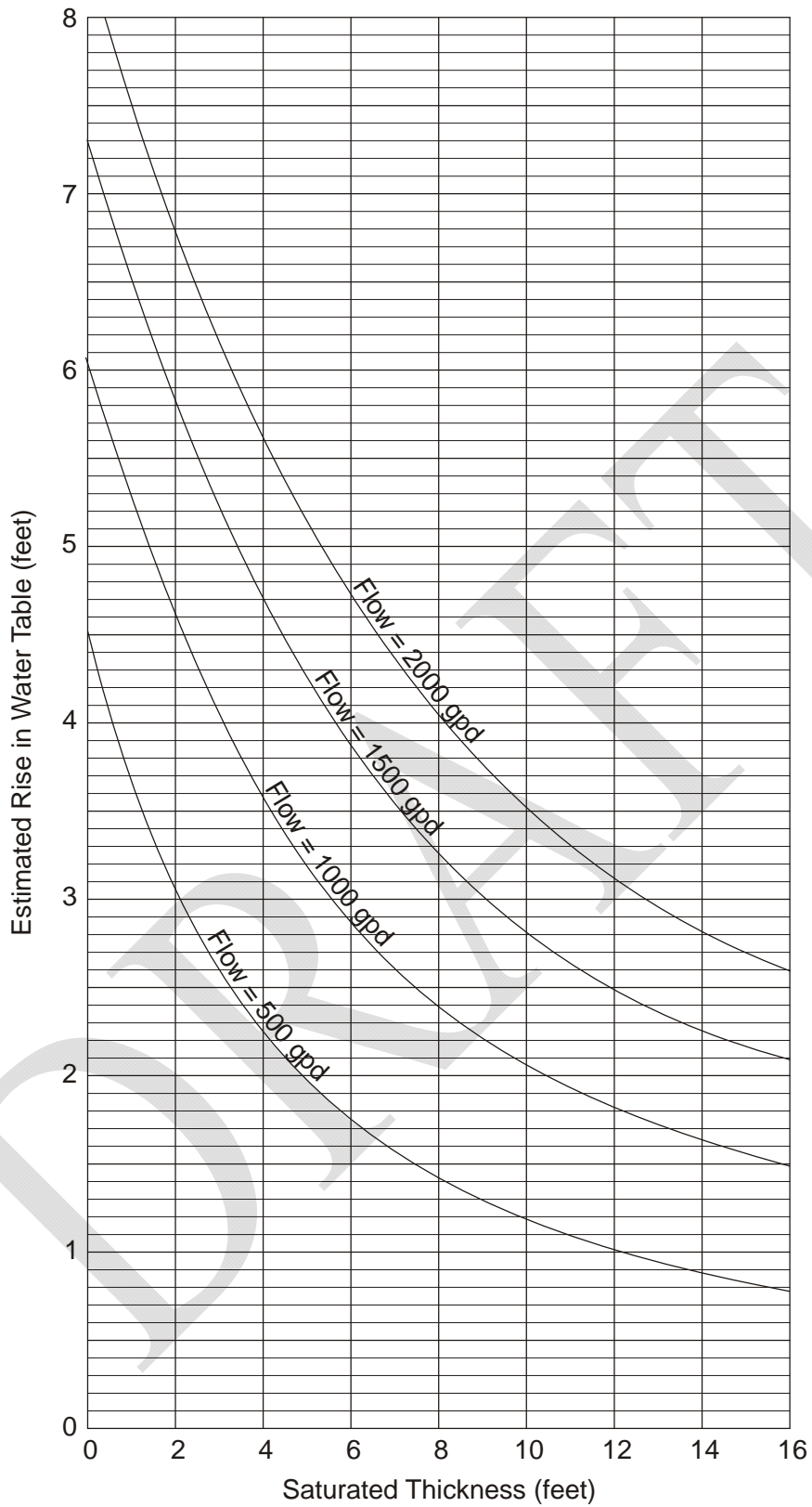

BASED ON A SOIL PERCOLATION RATE = 40 min/inch

FIGURE 4

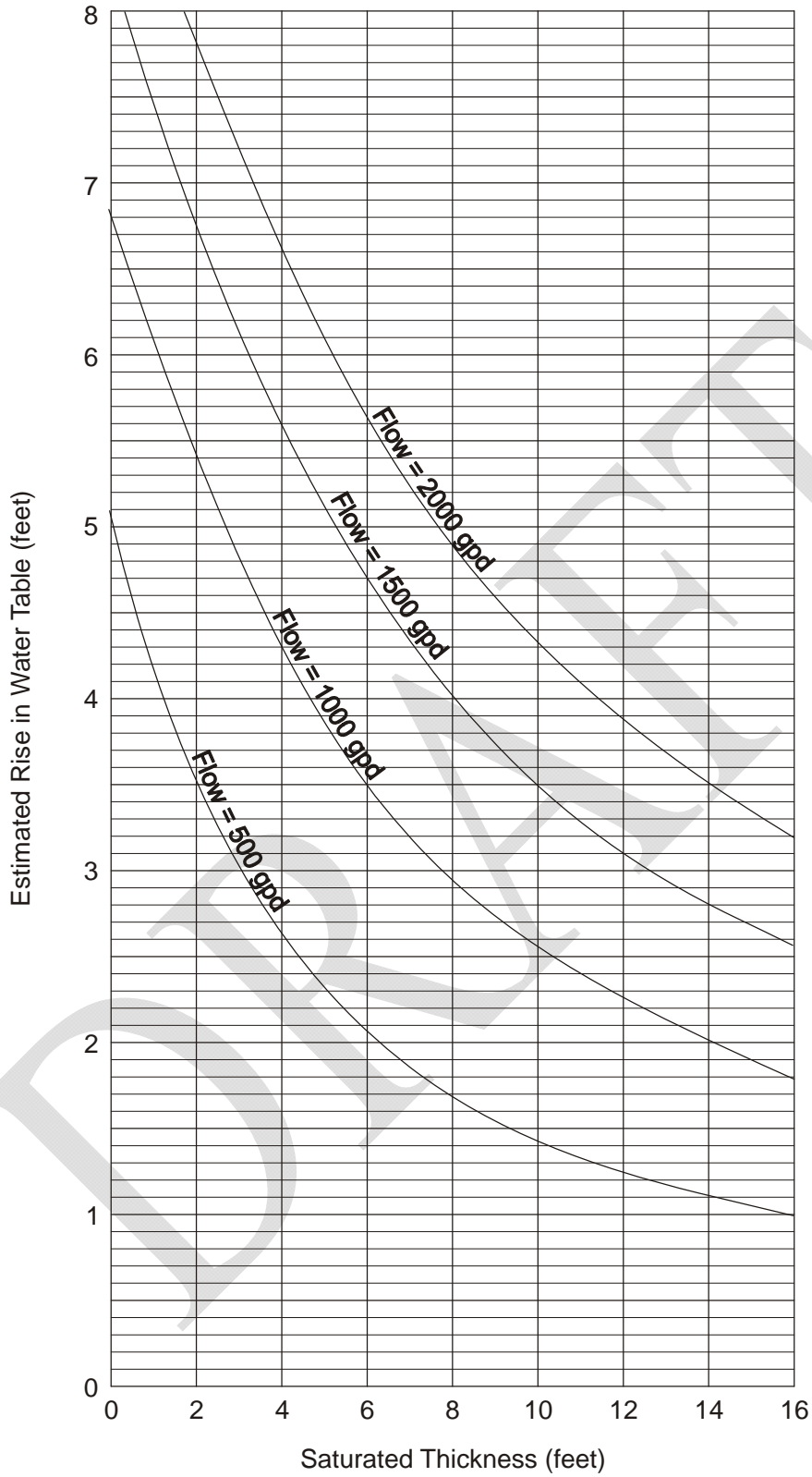

BASED ON A SOIL PERCOLATION RATE = 50 min/inch

FIGURE 5

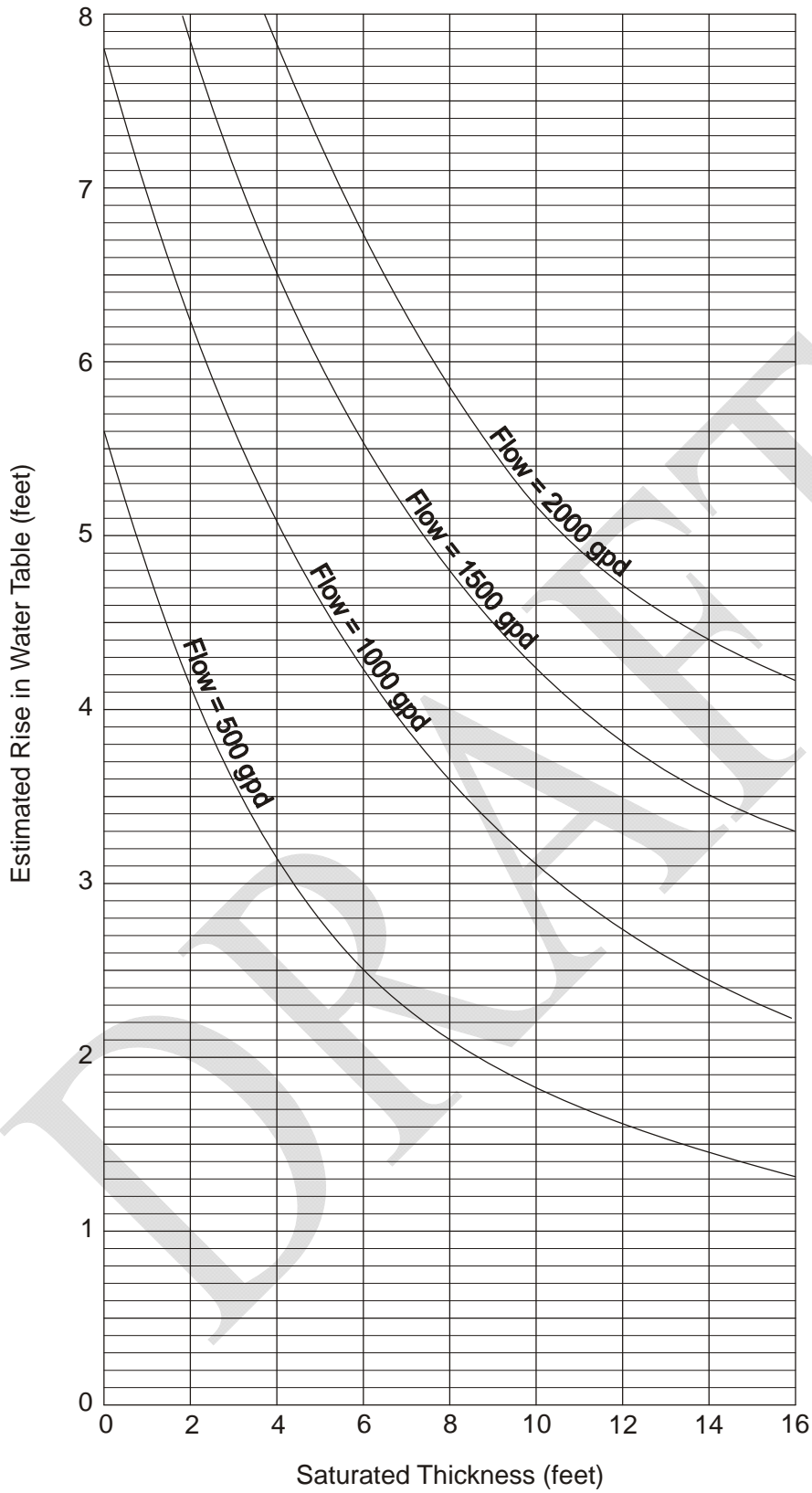

BASED ON A SOIL PERCOLATION RATE = 60 min/inch

FIGURE 6

~~(formerly Section 5(e))(e) Sloping ground installations~~ Slope

~~(formerly Section 5(e)(i))(i) Absorption systems shall not be located in an area where the natural slope is steeper than stated below. The natural slope of the site shall not exceed twenty-five percent 25%, 4-foot horizontal to 1-foot vertical.~~ The following are the maximum permissible slopes on which an absorption system may be constructed.

**Table 3. Slope and Percolation Rates for Absorption Systems**

Percolation Rate (minutes/inch)	Maximum Slope <sup>1</sup>
Faster than 5	25%
6-45	20%
46-60	15%

<sup>1</sup> Flatter slopes may be required where the effluent may surface downslope.

(ii) Serial distribution, with the use of drop boxes or approved fittings, is the preferred installation method for sloping terrain. The bottom of individual trenches shall be level and the trenches shall be constructed to follow the contours of the land.

(iii) The placement of multiple trenches, with each subsequent trench down slope of the previous trench shall be avoided when the addition of effluent to the soil absorption system trenches may lead to either an unstable slope or seepage down slope.

~~(formerly 5(e)(ii))(iv)~~ All absorption surfaces must be located at least 15 feet from the top of any break in slope which exceeds the maximum ~~allowed in subsection (i) above~~ slope allowed.

(f) Soil exploration pit and percolation tests

(i) Delegated small wastewater programs shall require a percolation test in addition to the soil exploration pit.

~~(ii) (formerly 5(a))~~ Soil exploration. Soil exploration. A minimum of one soil exploration pit within the proposed soil absorption system location shall be excavated ~~absorption system shall be made to provide information on subsoil conditions,~~ to a minimum depth of four (4) feet below the bottom of the proposed soil absorption system to evaluate the subsurface conditions.

~~(formerly 5(b))~~ Soil evaluation.

~~(formerly 5(b)(i))~~ No less than three percolation tests shall be run in the proposed absorption system location. The percolation tests shall be performed in accordance with Appendix A of this part. The type of soil encountered at the percolation test location shall be specified.

~~((formerly 5b)(ii))~~ (iii) An evaluation of the soil texture, in the proposed soil absorption system location, by a person experienced in soils classification, may be used to confirm the percolation rate. ~~but at least one percolation test shall be performed. The percolation test shall be performed in accordance with Appendix A of this chapter.~~

~~(formerly Section 4)(g)~~ Isolation Minimum horizontal setback distances (in feet) are as follows:

~~(formerly 4(a))~~— Domestic wastewater. The isolation distances listed below apply when domestic wastewater is the only wastewater present.

~~(formerly 4(a)(i))~~— If the flow is less than 2000 gallons per day (gpd), the minimum isolation distance (in feet) shown in Table 2 shall be maintained.

~~(formerly Table 2)~~ Table 4. Minimum Horizontal Setbacks<sup>1,2</sup>

From	To Septic Tank Or Equivalent	To Absorption System
Wells (includes neighboring wells)	50	100
<u>Public Water Well</u>	<u>50/300<sup>2</sup></u>	<u>200/600<sup>2</sup></u>
Property lines	10	10
Foundation Wall (w/o drains)	5	10
Foundation Wall (with drains)	5	25
Potable Water Pipes	25	25
Septic tank	<u>N/A</u>	10
<del>Stream or</del> Surface <del>Body of</del> Water, <u>Spring</u> (including seasonal and intermittent)	50	50
<u>Cisterns</u>	<u>25</u>	<u>25</u>

<sup>1</sup> ~~(formerly 4(b))~~ For disposal of ~~wastewaters other than domestic~~ non-domestic wastewater, the isolation distance shall be determined by a hydrogeological study in accordance with Section ~~15~~ 17(b) of Chapter 3, but shall not be less than the distances shown in Table 4.

<sup>2</sup> The larger horizontal setback shall apply when the soil absorption system discharges to the same aquifer that the public water well draws from. A hydrogeological study in accordance with Section 15(b) of Chapter 3 shall be performed to determine if the setback distance can be reduced.

~~(formerly 4(a)(ii))~~— If the flow is greater than 2000 gpd but less than 10,000 gpd, the minimum isolation distances (in feet) shown in Table 3 shall be maintained.

~~(Formerly) Table 3~~

<u>From</u>	<u>To Septic Tank Or Equivalent</u>	<u>To Absorption System</u>
<del>Wells (includes neighboring wells)</del>	<del>50</del>	<del>200</del>
<del>Property lines</del>	<del>10</del>	<del>10</del>
<del>Building Foundation (without foundation drains)</del>	<del>5</del>	<del>10</del>
<del>Building Foundation (with foundation drains)</del>	<del>5</del>	<del>50</del>

Potable Water Pipes	25	50
Septic tank		10
Stream or Surface Body of Water (including seasonal and intermittent)	50	100

(iii) For systems larger than 10,000 gallons per day, the isolation distance shall be determined by a hydrogeological study in accordance with Section 15(b) of Chapter III, but shall not be less than those in subsection two above.

**Section 7. Soil Absorption System Sizing.**

~~(formerly 7(a)) Trench, bed and seepage pit systems.~~ The total infiltrative surface of a soil absorption system area of a soil absorption system shall be calculated ~~based on the flow rate as determined by the criteria stated in Section 3 and with the allowable loading rate as determined by using Figure 7.~~ by dividing the design flow rates (gpd) from Table 1 or Table 2 by the loading rate (gpd/ft<sup>2</sup>) found in Table 5. ~~The total infiltrative surface is the sum of the sidewall and bottom areas of the absorption system below the invert of the distribution pipe.~~

(b) ~~Soils with a percolation rate of 60 minutes per inch or greater are unacceptable for standard absorption systems.~~ The total infiltrative area shall be defined as follows:

(i) For standard trenches, perforated pipe embedded in aggregate, the total infiltrative area shall be calculated by multiplying the total length of the trench (ft) by the sum of the bottom width (ft) and the height (ft) of each sidewall. The sidewall height is the depth below the flowline of the pipe to the bottom of the trench. The maximum credit for sidewall height shall not exceed twelve (12) inches even if the actual sidewall height exceeds twelve (12) inches.

(ii) For chamber trenches, the total infiltrative area shall be calculated by multiplying the total length of the trench (ft) by the sum of the bottom width (ft) of the chamber and the height (ft) of each sidewall. The sidewall height is the height of the slotted sidewall of the chamber. The maximum credit for sidewall height shall not exceed twelve (12) inches even if the actual sidewall height exceeds twelve (12) inches.

(iii) For bed systems, the total infiltrative area shall be calculated by multiplying the total length (ft) by the width (ft) of the bed. The sidewall credit shall not be used in calculating the total infiltrative area for a bed system.

~~(formerly 5(d))(c) Excessively permeable soils.~~ Coarse sand or soils having a percolation rate ~~of less than one (1) minute per inch or less~~ are unsuitable for subsurface ~~effluent sewage~~ disposal. These soils may be used if ~~a six inch a one (1) foot layer of soil fine sand or loamy sand having a percolation rate of five minutes per inch or greater~~ is placed ~~between the leach system stone and the existing soil~~ below the constructed soil absorption system. The soil absorption system shall be sized based on the percolation rate of the fill material



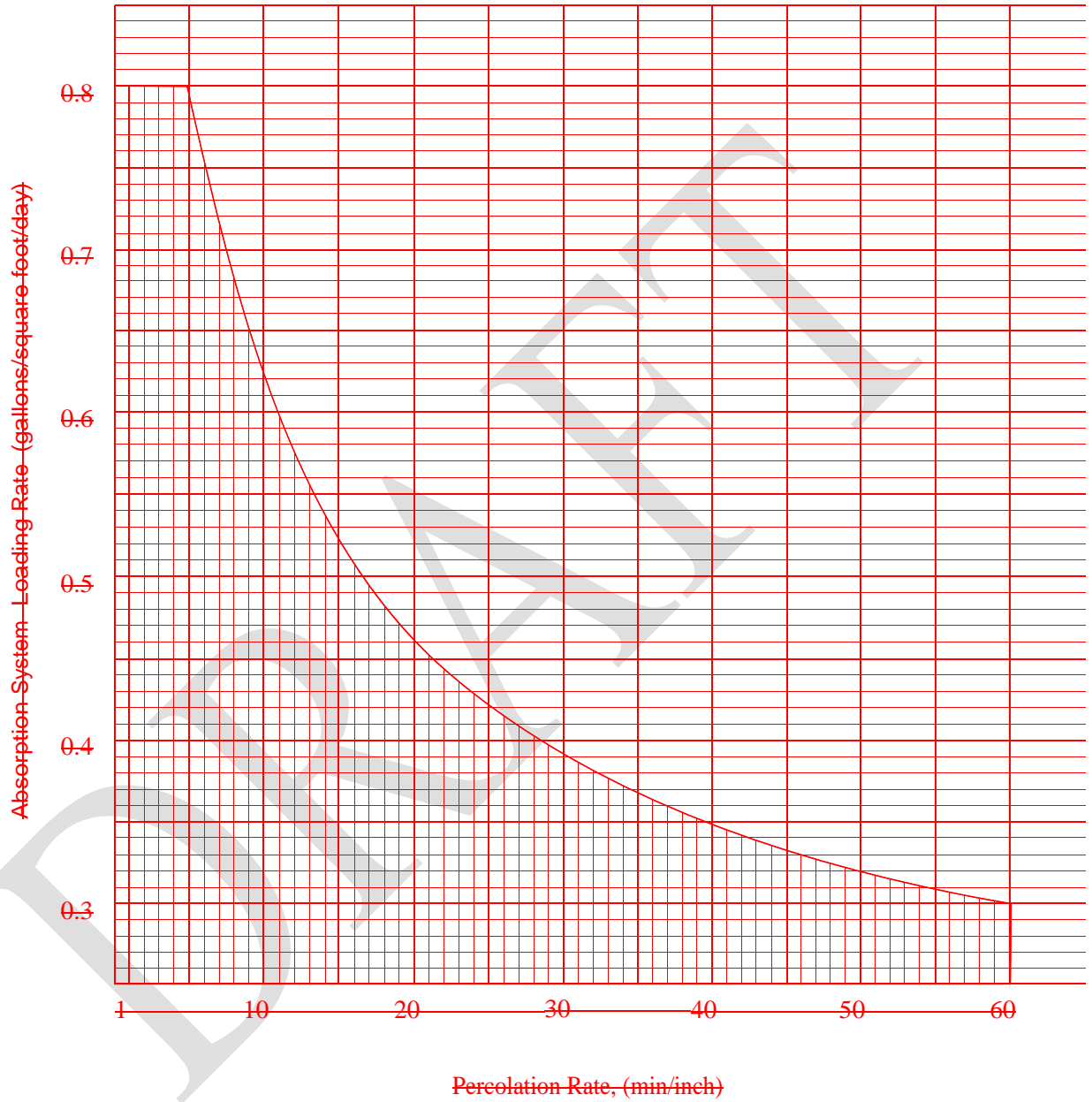

FIGURE 7

**Table 5. Rates of Wastewater Application for Soil Absorption System Areas**

<u>Percolation Rate (mpi)</u>	<u>Loading Rate (gpd/ft<sup>2</sup>)</u>	<u>Percolation Rate (mpi)</u>	<u>Loading Rate (gpd/ft<sup>2</sup>)</u>
<u>1-5</u>	<u>0.80</u>	<u>33</u>	<u>0.38</u>
<u>6</u>	<u>0.75</u>	<u>34</u>	<u>0.37</u>
<u>7</u>	<u>0.71</u>	<u>35</u>	<u>0.37</u>
<u>8</u>	<u>0.68</u>	<u>36</u>	<u>0.36</u>
<u>9</u>	<u>0.65</u>	<u>37</u>	<u>0.36</u>
<u>10</u>	<u>0.62</u>	<u>38</u>	<u>0.35</u>
<u>11</u>	<u>0.60</u>	<u>39</u>	<u>0.35</u>
<u>12</u>	<u>0.58</u>	<u>40</u>	<u>0.35</u>
<u>13</u>	<u>0.56</u>	<u>41</u>	<u>0.34</u>
<u>14</u>	<u>0.54</u>	<u>42</u>	<u>0.34</u>
<u>15</u>	<u>0.52</u>	<u>43</u>	<u>0.34</u>
<u>16</u>	<u>0.50</u>	<u>44</u>	<u>0.33</u>
<u>17</u>	<u>0.49</u>	<u>45</u>	<u>0.33</u>
<u>18</u>	<u>0.48</u>	<u>46</u>	<u>0.33</u>
<u>19</u>	<u>0.47</u>	<u>47</u>	<u>0.32</u>
<u>20</u>	<u>0.46</u>	<u>48</u>	<u>0.32</u>
<u>21</u>	<u>0.45</u>	<u>49</u>	<u>0.32</u>
<u>22</u>	<u>0.44</u>	<u>50</u>	<u>0.32</u>
<u>23</u>	<u>0.43</u>	<u>51</u>	<u>0.31</u>
<u>24</u>	<u>0.43</u>	<u>52</u>	<u>0.31</u>
<u>25</u>	<u>0.42</u>	<u>53</u>	<u>0.31</u>
<u>26</u>	<u>0.41</u>	<u>54</u>	<u>0.31</u>
<u>27</u>	<u>0.41</u>	<u>55</u>	<u>0.31</u>
<u>28</u>	<u>0.40</u>	<u>56</u>	<u>0.30</u>
<u>29</u>	<u>0.40</u>	<u>57</u>	<u>0.30</u>
<u>30</u>	<u>0.39</u>	<u>58</u>	<u>0.30</u>
<u>31</u>	<u>0.39</u>	<u>59</u>	<u>0.30</u>
<u>32</u>	<u>0.38</u>	<u>60</u>	<u>0.30</u>

**Section 8. ~~(formerly Pretreatment)~~ Building Sewer Pipes.**

~~(formerly 6(a))~~ — ~~Building drain pipe. All building drain pipe shall comply with the standards published in the Uniform Plumbing Code 1982 or other locally approved, nationally recognized plumbing code.~~

~~(formerly 6(b))~~ All building sewers shall be installed in accordance with the ~~Uniform Plumbing Code 1982 or other locally approved, nationally recognized plumbing code~~ 2012 International Plumbing Code (IPC). In the absence of an approved plumbing code, and in addition to the IPC, the building sewer shall comply with the following:

~~(formerly 6(b)(i))~~ (a) ~~(Material) Suitable building sewer pipe materials are Polyvinyl Chloride (PVC) and Acrylonitrile-Butadiene-Styrene (ABS) east or ductile iron, portland cement, or vitrified clay pipe shall be used for sewer pipes.~~ The septic tank inlet and outlet pipes shall be ~~east or ductile iron or~~ schedule 40

PVC or ABS pipe and shall ~~extend past the septic tank excavation to solid ground~~ span the excavations for the septic tank and/or dosing chamber. American Society for Testing and Materials (ASTM) D-3034 Standard Dimension Ratio (SDR) 35 plastic pipe may be used if the void at the tank's side is filled with material which is granular, clean and compacted.

~~(formerly 6(b)(ii))~~ (b) **Size.** Building sewer pipes shall not be smaller than four (4) inches in diameter. ~~They shall be~~ and sized to handle the peak hourly flow from the building. When two different sizes or types of sewer pipes are to be connected, a proper type of fitting or conversion adapter shall be used.

(c) Sewer pipe shall not decrease in size flowing downstream.

~~(formerly 6(b)(iii))~~(d) **Slope.** Building sewer pipes ~~shall should~~ be laid at a ~~minimum~~ standard slope of 1/4 inch per foot, but shall not be flatter than 1/8 inch per foot.

~~(formerly 6(b)(iv))~~ **Alignment.** ~~Building sewer pipes should be laid in a straight line. Any single change or cumulative change of alignment of 22 1/2 degrees or greater shall be served by a cleanout.~~

~~(formerly 6(b)(v))~~(e) **Cleanouts.** Cleanouts shall be provided at branch connections, every change in alignment, and at least every 100 feet in straight runs ~~maximum~~.

~~(formerly 6(b)(vi))~~(f) **Backfilling.** All sewer piping shall be laid on a firm bed throughout its entire length. It shall be protected from damage due to rocks, hard lumps of soil, debris and the like.

~~(formerly 6(b)(vi))~~(g) Special care shall be utilized to prevent lateral movement or ~~ovalation~~ deformation during backfill. The backfill material shall be compacted to a density at least equivalent to the trench walls. Backfill over the pipe shall be of sufficient depth to protect the pipe from expected traffic loads and the wastewater from freezing.

### **Section 9. ~~Dosing Systems Following Septic Tanks~~ Septic Tanks and Other Treatment Tanks.**

~~(formerly 8(a))~~(a) Septic tanks:

~~(formerly 8(a)(i))~~ (i) **Material.** ~~The~~ Septic tanks shall be fabricated or constructed of durable concrete, fiberglass or an approved material ~~not subject to excessive corrosion or decay and structurally capable of supporting the loads to which it will be subjected. The tank shall be water tight.~~ The Tanks shall be water tight and fabricated to constitute an individual structure, and shall be designed and constructed to withstand anticipated loads. The design of prefabricated septic tanks shall be reviewed for compliance with applicable construction standards prior to approval for installation.

~~(formerly 8(a)(v))~~ (ii) **Installation.** The septic tank shall be placed on a level grade and a firm bedding to prevent settling. Where rock or other undesirable protruding obstructions are encountered, the opening for the septic tank shall be over excavated, as needed, and backfilled with sand, crushed stone, or gravel to the proper grade.

(A) Septic tanks shall not be buried deeper than the tank manufacturer's maximum designed depth for the tank. The minimum depth of soil cover over the top of the tank is six (6) inches.

(B) Backfill around and over the septic tank shall be placed in such a manner as to prevent undue strain or damage to the tank or connected pipes.

(C) Septic tanks shall not be placed in areas subject to vehicular traffic unless engineered for the anticipated load.

~~(formerly 8(a)(ii))(iii)~~ Size-

~~(formerly 8(a)(ii)(A)(A) Residential units serving no more than 4 families.~~  The minimum liquid volume of a septic tanks shall be 1000 gallons for residences through four bedroom capacity up to a six (6) bedroom capacity. Additional capacity of 250 150 gallons per bedroom shall be provided for each bedroom over four six (6).

~~(formerly 8(a)(ii)(B)(B) Commercial/industrial units.~~ Septic tanks for high strength wastewater or non-residential units shall have a minimum effective liquid capacity sufficient to provide at least 36 48 hour retention at peak flow or 1,000 gallons, whichever is greater.

~~(formerly 8(a)(iii))(iv)~~ Configuration

~~(formerly 8(a)(iii)(A)(A) The Single compartment septic tanks shall have a length to width ratio of no less than two (2) to one (1), or be so partitioned as to provide protection protect against short circuiting of flow. The water depth shall be no less than four feet nor greater than six feet. The inlet pipe shall be at least three inches higher than the outlet pipe.~~ 

~~(formerly 8(a)(iii)(B)(B) If the septic tank is partitioned, For septic tanks with two (2) compartments or more the volume of the first compartment must be at least 50 percent of the total required volume, the inlet compartment shall not be less than one-half (1/2) of the total capacity of the tank. The partition shall allow venting of the tank. The liquid depth shall not be less than three (3) feet nor greater than six (6) feet.~~

~~(formerly 8(a)(iii)(C))(C) The outlet elevation shall be designed to provide a distance of 20 percent of the liquid depth between the top of the liquid and the bottom of the septic tank cover for scum storage. The tank partition shall allow the venting of gases between compartments and out through the vent stack on the plumbing system of the house. Gases generated during liquefaction of the solids are normally vented through the building's plumbing stack vent.~~

~~(formerly 8(a)(iii)(A))(D) The septic tank inlet and outlet on all tanks or tank compartments shall be provided with a open-ended sanitary tees or baffles. The outlet shall be provided with a tee or baffle that extends into the middle third of the water depth to prevent floating or settled solids from carrying over into the disposal field or bed. The inlet shall be provided with tee or baffle made of approved materials constructed to distribute flow and retain scum in the tank or compartments.~~

(I) The tees or baffles shall extend a minimum of six (6) inches above and nine (9) inches below the liquid level, but shall not exceed one-third (1/3) the liquid depth.

(II) A minimum of three (3) inches of clear space shall be provided over the top of the baffles or tees.

~~(formerly 8(a)(iii)(A)) (III) The inlet pipe shall be at least three two (2) inches higher than the outlet pipe. (formerly 8(a)(iii)(C)) The outlet elevation shall be designed to provide a minimum distance~~

of nine (9) inches or twenty (20) percent of the liquid depth, whichever is greater, between the top of the liquid and the bottom of the septic tank cover for scum storage and the venting of gases.

(v) If additional septic tank capacity over 1,000 gallons is needed, it may be obtained by joining tanks in series provided the following requirements are met:

(A) The outlet of each successive tank shall be at least two (2) inches lower than the outlet of the preceding tank, and shall be unrestricted except for the inlet to the first tank and the outlet for the last tank.

(B) The first tank or the first compartment of the first tank shall be equal to fifty percent (50%) or larger of the total septic tank system volume.

~~(formerly 8(a)(iv))(vi) — Access. A manway access riser shall be provided to each compartment of the septic tank for inspection and cleaning. A cleanout having a minimum diameter of six inches shall be provided in each tank compartment and shall extend to the ground surface and be capped.~~

~~(formerly 8(a)(iv)) (A) The manway access riser shall have a minimum opening diameter of twenty (20) inches in the least dimension. Both inlet and outlet devices shall be accessible.~~

(B) The riser shall terminate at a maximum of six (6) inches below the ground surface. Riser covers terminating above grade shall have an approved locking device.

(vii) Land application of domestic septage in remote areas that meet the conditions found in Appendix B will be permitted as a permit by rule. Delegated small wastewater programs may issue individual permits.

(viii) An effluent filter with an opening of 1/8-inch or smaller shall be provided on the outlet of a septic tank or other tank that precedes a small diameter pressure distribution system.

~~(formerly 8(b)) — Aerobic units.~~

~~(formerly 8(b)(i)) Residential units serving no more than four dwelling units. Aerobic treatment units can be used as a pretreatment device for a single residential unit serving no more than four families provided the unit carries the seal of testing and approval from the National Sanitation Foundation (NSF) for the NSF Standard No. 40—1978. The unit shall be sized based on the flow quantities stated in Section 3. No reduction in the sizing of soil absorption systems or the final treatment systems shall be permitted if an aerobic unit is used instead of a septic tank.~~

~~(formerly 8(b)(ii)) Commercial and residential units serving more than four families. Aerobic units treating wastewater generated from other than a single residential unit serving four families or less shall meet the design requirements of Part B or Part C of Chapter XI~~

~~(formerly 9(a))(b) Pumping systems for flow up to 2000 gallons per day. Dosing tanks~~

~~(i) Pump tank. Where only one pump is provided, the pump tank shall have the minimum volume as required in Table 4 below. The Dosing tanks shall comply with the meet the same material and installation requirements for as septic tanks. The pump tank shall be vented. The vent shall have a downward turn that terminates at least 12 inches above ground and be provided with~~

~~a screen. The pump tank shall have an access manhole provided with an opening at least 20 inches in least dimension. Dosing tanks shall have a 20-inch diameter access riser and it shall be brought to the ground surface.~~

**Table 4**

Pump Tank  
Volume (gallons) Required Between

AVERAGE FLOWS (gallons per day)	“OFF” & “ON” SWITCH	“ON” & “ALARM” SWITCH	“ALARM” SWITCH & TANK INLET	RECOMMENDED PUMP CAPACITY (gpm)
0-499	100	50	200	10
500-999	200	100	400	20
1000-1499	300	100	600	30
1500-2000	400	100	800	40

**Table 6. Dosing Tank Volume (gallons)**

Average Wastewater Flows (gpd)	0-499	500-999	1000-1499	1500-2000
Between Pump “off” and Tank Inlet	350	700	1000	1300
Between Tank Inlet and Alarm Switch	200	400	600	800
Between Alarm switch and Pump “on”	50	100	100	100
Between Pump “on” and Pump “off”	100	200	300	400
Recommended Pump Capacity (gpm)	10	20	30	40

(ii) — Pumps:

(A) — Sizing. ~~The pump shall have a flow rate of at least ten gallons per minute when installed. The pressure loss (feet of head) of the system can be calculated by adding: the elevation difference between the discharge outlet at the soil absorption system and the low water level in the pump tank; and the friction losses incurred in the pressure transfer pipe and distribution piping. Table 5 may be used to estimate the head loss of the pipe when pumping ten gallons per minute and using plastic pipe.~~

**Table 5**

Diameter (inches)	Head Loss per 100 feet of pipe (in feet)
1	12
1/4	4
1/2	2

(B) — Installation/removal. ~~The pump shall be installed in the tank so that it can be~~

removed without entering the tank. This can be accomplished by (1) looping the pipe up near the access manhole with a pipe union provided at the top of the loop, (2) using a quick disconnect sliding coupler, or (3) using a pitless adapter. Chains, cable, or piping can be used to lift the pump out of the tank if designed for this loading. Setting the pump on an 8-inch block minimizes the transfer of any solids that may enter the pump tank.

(iii) ~~Pressure transfer pipe.~~ The pressure transfer piping between the tank and the leach system shall be designed to drain after each pump cycle to prevent freezing. This can be accomplished by either eliminating the check valve at the pump or by providing a weep hole in the pipe in the tank. If the pipe is long, the tank shall be enlarged by the volume of the pipe to accommodate the volume of liquid drained from the pipe.

(b) ~~Syphons.~~ Where automatic syphons are used, they shall be designed to empty the syphon tank in less than 20 minutes. The syphon tank shall be sized in accordance with Section 9(a)(i) above.

(c) ~~For all systems exceeding 2000 gallons per day.~~ The pumping system shall comply with the standards of Part B of Chapter XI.

~~(formerly 9(a)(ii)(C))~~ (ii) ~~Electrical controls.~~ The electrical control system for the wastewater pump shall consist of a “pump off” switch, a “pump on” switch, and a “high water alarm” switch which shall be located to provide the necessary volumes as stated in Table 4. High water alarms shall be provided for all tanks that utilize pumps or syphons. The alarm device shall be an audible alarm or an indoor illuminated alarm or both. All electrical controls (pump electrical cord, switches, etc.) shall comply with the National Electrical Code—1981, Class 1, Group D, Division 1 locations. All openings around the cables or cords entering the tank shall be sealed.

(iii) The minimum effluent level shall achieve complete submergence of the pump.

(iv) Dosed systems using a siphon shall have a dose counter installed to check for continued function of the siphon.

~~(formerly Section 12)~~ (c) Holding tanks

(i) Holding tanks shall meet the same material requirements as septic tanks. Holding tanks shall have a twenty (20)-inch minimum diameter access riser and it shall be brought to ground surface.

~~(formerly 12(a))~~ (ii) Uses. Holding tanks shall not be used for residential systems when other alternative systems are available, except on a temporary, seasonal or intermittent basis, or when used to correct a failed subsurface disposal system when other alternatives are unavailable. ~~Use of holding tanks for new construction is prohibited.~~

~~(formerly 12(b))~~ ~~Acceptance.~~ A letter of verification from the local receiving agency, denoting acceptance of the wastewater generated shall be submitted with the plans.

(iii) ~~(formerly 12(c))~~ ~~Location.~~ The location and construction of holding tanks shall meet the requirements for septic tanks in Sections 4(a)(i) and Section 8(a)(i) respectively. Holding tanks must be located in an area readily accessible to the pump truck and where the tank itself will not float due to a high groundwater. If seasonal high groundwater may be present, the tank shall be properly anchored.



~~(formerly 12(a)) (iv) Where holding tanks are allowed, they shall be sized on the basis of seven days storage at the flow rate determined from Table 1. The minimum liquid volume shall be the greater of 1,000 gallons or seven (7) days storage based upon flow rate determined from Section 4.~~

~~(formerly 12(d)) Vent. Each holding tank shall be provided with a two inch minimum diameter vent ending in a return elbow above final grade. The vent shall terminate at least 30 feet from any door, window, or fresh air inlet. The vent should be screened.~~

~~(formerly 12(e)) (v) Alarm. All holding tanks shall be equipped with a high water-level alarm. The device shall be an audible alarm or an indoor illuminated alarm or both. The alarm level shall be placed at 3/4 the depth of the tank.~~

~~(formerly 12(f)) Pumpout. A six inch pump out pipe which extends to the surface shall be provided. It shall be capped at all times.~~

~~(formerly 9(e)(d) Grease Interceptors~~

~~(e) Interceptors grease, oil, silt and sand.~~

~~(i) When required. Liquid wastes containing grease, oil, or silt and sand A commercial or institutional food preparation facility with a waste stream containing fat, oil, and grease (FOG) in excess of 25 mg/L shall provide install an exterior grease interceptor or a device approved by the delegated health department or county before the septic tank. Waste streams from residential living units are exempt from this requirement. Facilities that typically have waste streams high in FOG are, but not limited to, restaurants, cafeterias, slaughterhouses, or institutional kitchens.~~

~~(ii) Material. The interceptor shall meet the material requirements of Section 8(a)(i). Waste streams high in FOG shall be plumbed separately and directly to a grease interceptor prior to the waste treatment process.~~

~~(iii) Waste streams from sanitary facilities such as bathrooms, toilets, urinals, or other similar fixtures shall not be discharged into the grease interceptor. These sources must be connected at least 4-6 feet downstream of the grease interceptor's discharge. The design shall prevent any backflow from the sanitary sources into the grease interceptor.~~

~~(iv) Only one source facility per grease interceptor shall be allowed.~~

~~(formerly 8(e)(v)) Access. The access shall meet the requirements of Section 8(a)(iv).~~

~~(formerly 8(e)(vi)) Location. (v) Grease interceptors shall be located so that they are easily accessible for inspection, cleaning, and removal of the collected wastes. Interceptors shall be placed as close as practical to the fixture it serves. The wastewater from fixtures not producing grease, oil, or sand and silt shall bypass the interceptor. The interceptor shall not be closer than fifteen (15) feet from the last discharging fixture and no further away than thirty-five (35) feet.~~



~~(formerly 8(e)(iv))~~ (vi) ~~Configuration. Grease~~ interceptors shall have ~~a minimum~~ of two (2) compartments with ~~the first compartment having at least 50 percent of the total required volume~~ a 20-inch minimum diameter clean out riser for each compartment. ~~Each compartment shall be vented. Each clean out riser shall be brought to the surface and have a sealed lid that is rated for any anticipated load. There shall be a means provided to sample the effluent.~~

(vii) There shall be no internal cleanout tees or bypasses.

(viii) The inlet and outlet of the grease interceptor shall be vented. The vent pipe shall be at least two (2) inches in diameter. The inlet and outlet vents shall not be interconnected.

(ix) The outlet pipe invert shall be no more than two (2) inches lower than the inlet invert.

(x) The dividing wall between compartments shall be the same height as the other walls and the cover must contact the top of the dividing wall.

(xi) The effluent from each compartment shall be drawn from the bottom of a riser pipe that terminates at least eighteen (18) inches below the inlet pipe invert of that same compartment.

(xii) Grease interceptors shall be accessible during normal business hours without interrupting normal business operations.

(xiii) Grease interceptors shall be installed in accordance with the manufacturer's instructions and applicable requirements of this section. A copy of the manufacturer's instructions shall be submitted with every permit to construct application submitted to DEQ.

~~(formerly 8(e)(iii))~~ (xiv) Grease interceptors shall be sized ~~using one of the~~ according to the following ~~formulas~~:

(A) The minimum volume shall not be less than 750 gallons.

(B) Shall be sized according to the following:

~~Commercial kitchens (grease, garbage)~~

Number of meals per peak hour	X	Waste Flow rate*	X	Retention time**	X	Storage factor***	=	Interceptor size(liquid capacity)
-------------------------------	---	------------------	---	------------------	---	-------------------	---	-----------------------------------

~~Car wash (sand, silt, oil)~~

Total washer equipment flow rate (GPM)	X	60	X	Retention time	X	Storage factor	=	Interceptor size (liquid capacity)
--	---	----	---	----------------	---	----------------	---	------------------------------------

**Laundries (grease, lint, silt)**

Number of 2 cycles machines X per hour	X	Waste flow rate	X	Retention time	X	Storage factor	=	Interceptor size (liquid capacity)
--	---	-----------------	---	----------------	---	----------------	---	------------------------------------

\*Waste flow rate—see Table 1.

\*\* Retention Times

Commercial kitchen waste:	
Dishwasher and/or disposal	2.5 hours
Single service kitchen:	
Single serving with disposal	1.5 hours
Car washers	2.0 hours
Laundries	2.0 hours

\*\*\*Storage Factors

Fully equipped commercial kitchen	8 hr. operation: 1 16 hr. operation: 2 24 hr. operation: 3
Single service kitchen	1.5
Carwashers	self-serve: 1.5 employee operated: 2
Laundries	1.5 (allows for rock filter)

**Commercial Kitchens (grease, garbage)**

<u>Number of meals per peak hour</u>	<u>X</u>	<u>Waste Flow rate*</u>	<u>X</u>	<u>Retention time**</u>	<u>X</u>	<u>Storage factor***</u>	<u>=</u>	<u>Interceptor size (liquid capacity)</u>
--------------------------------------	----------	-------------------------	----------	-------------------------	----------	--------------------------	----------	---

\*Waste flow rate – see Table 2.

\*\*Retention times

<u>Kitchen waste:</u>	
<u>Dishwasher and/or disposal</u>	<u>2.5 hours</u>
<u>Single service kitchen:</u>	
<u>Single serving with disposal</u>	<u>1.5 hours</u>

\*\*\*Storage factors

<u>Fully equipped commercial kitchen</u>	<u>8 hr. operation: 1</u> <u>16 hr. operation: 2</u>
--	---

	<u>24 hr. operation: 3</u>
<u>Single service kitchen:</u>	<u>1.5</u>

(e) Other interceptors

(i) Interceptors are required for oil, grease, sand and other substances harmful or hazardous to the building drainage system, or the small wastewater treatment system.

(A) Laundries

(I) Commercial laundries, Laundromats, and dry-cleaners shall be equipped with an interceptor in order to reduce the quantity of lint and silt that enter the collection system.

(II) The system must be of adequate size and design to allow for cool-down of wastewater so that separation can be more readily achieved.

(III) The interceptor must be installed with a wire basket or similar device, removable for cleaning, that prevents passage into the drainage system of solids ½ inch (12.7 mm) or larger in size, string, rags, buttons, or other materials detrimental to the waste treatment system.

(IV) Sizing must be in accordance with the following formula:

**Laundries (grease, lint, silt)**

<u>Total gallons per cycle</u>	<u>X</u>	<u>Cycles per hour</u>	<u>X</u>	<u>Retention time*</u>	<u>X</u>	<u>Storage factor**</u>	<u>≡</u>	<u>Lint interceptor</u>
--------------------------------	----------	------------------------	----------	------------------------	----------	-------------------------	----------	-------------------------

\*Retention times

<u>Institutional laundries</u>	<u>2.5 hours</u>
<u>Standard commercial laundry</u>	<u>2.0 hours</u>
<u>Light commercial laundry</u>	<u>1.5 hours</u>

\*\*Storage factors

<u>8 hours of operation</u>	<u>1.0</u>
<u>12 or more hours of operation</u>	<u>1.5</u>

(B) Car Washes

(I) Where automobiles are washed (including detail shops utilizing hand-wash practices), separators shall have a minimum capacity of 1000 gallons for the first bay, with an additional 500 gallons of capacity for every other bay.

(II) Additionally, wash racks must be constructed to eliminate or minimize the impact of run-off from rain/storm events. Minimum requirements are roofed structures with at least two walls and appropriate grading to prevent stormwater infiltration into the sanitary sewer.

(III) An effluent sampling point is required.

(f) Abandonment of septic and holding tanks

The following is the procedure to abandon septic tanks and holding tanks when the system is upgraded, equipment replacement is necessary, or central sewer lines are made available.

(i) The abandoned tank should be pumped and the septage hauled to a licensed facility approved to receive the waste or pump the septage into the newly constructed septic or holding tank. Discharging to a central sewer requires coordination with, and the approval of, the owner/operator of the sewer system.

(ii) Once the abandoned tank is empty, it should be removed and the excavation backfilled. As an alternative to removing the tank, the access covers can be removed and the tank filled with native soil, pit run, or sand.

(iii) If the abandoned tank is part of a Class V UIC facility, the abandonment must also be in compliance with Chapter 16, Section 12.

#### **Section 10. ~~Subsurface Treatment and Disposal Systems~~ Effluent Distribution Devices.**

Distribution boxes and flow divider tees are suitable for level or nearly level ground and are installed before the soil absorption system with the goal of splitting flows equally between soil absorption system laterals. Drop boxes are suitable for sloping ground and are installed to achieve serial loading.

(a) Distribution boxes

~~(formerly 10(a)((vii)(i) Distribution box. If a~~ The distribution box is used, it shall be installed to provide uniform distribution of the wastewater on a level, stable base to ensure against tilting or settling and shall be placed so that it will not be subject to and to minimize movement from frost heave.

(ii) Boxes shall be watertight and constructed of concrete or other durable material.

(iii) Boxes shall be designed to accommodate the inlet pipe and the necessary distribution lines. The inlet piping to the distribution box shall be at least one (1) inch above the outlet pipes and all pipes shall have a watertight connection to the distribution box.

(iv) The box shall be protected against freezing and made accessible for observation and maintenance.

(v) Boxes shall have flow equalizers installed on each outflow 

(b) Flow divider tees may be used in place of distribution boxes.

(c) Drop boxes are suitable for sloping ground and are installed to achieve serial loading. The drop boxes shall meet the requirements in paragraphs (a)(i through v) of this section.

#### **Section 11. ~~Evapotranspiration Beds~~ Standard Soil Absorption Systems.**

~~(a) Sizing. The area of evapotranspiration beds shall be determined using the following formula:~~

~~$$\text{AREA} = 586 \left[ \frac{Q}{\text{PET} - P} \right]$$~~

~~where:~~

~~Area = Area of the evapotranspiration bed at the ground surface in square feet~~

~~Q = Average daily sewage flow, gallons per day, (0.6 times the flow determined from Table 1)~~

~~PET = Potential evapotranspiration rate in inches per year~~

~~P = Annual precipitation rate in inches per year.~~

~~(b) Construction.~~

~~(i) If an impervious barrier is necessary for the protection of groundwater it shall be installed between the evapotranspiration bed and the native soil. It shall be a polyvinyl chloride sheet with a minimum thickness of 20 mils or equivalent. A 3 inch layer of sand shall be placed under and over the liner.~~

~~(ii) The bottom 12 inches of the bed shall be filled with clean stone 1/2 - 2 1/2 inches in~~

~~(iii) Perforated pipe complying with Section 10(a)(v) shall be placed in the stone.~~

~~(iv) Four inches of pea gravel (less than 1/4 inch in diameter) or durable filter cloth shall be placed over the stone.~~

~~(v) A 24 inch uniform sand layer in the size range of D50 (0.10mm) shall be placed on top of the pea gravel or filter cloth.~~

~~(vi) A six inch layer of sandy topsoil shall be placed on top of the evapotranspiration bed.~~

~~(vii) The bed should be vegetated with small shrubs and/or grasses such as fescue, brome, or alfalfa.~~

~~(viii) The evapotranspiration bed shall be placed at a depth sufficient to prevent surcharging of the septic tank.~~

~~(formerly 10(a)-(a) General Design Requirements:~~

~~(i) All soil absorption systems shall be designed in such a manner that the effluent is effectively filtered and retained below ground surface. The absorption surface accepts, treats, and disperses wastewater as it percolates through the soil.~~

~~(formerly 10(a)(ii)(ii) Protection. Effort shall be made to protect the natural absorptive properties of the soil. Soil absorption systems shall not be installed during adverse weather or soil conditions. Rain, severely cold temperatures, or excessively moist soils are considered adverse weather or soil conditions.~~

~~All smeared or compacted surfaces shall be restored to their original infiltrative conditions prior to placement of the stone.~~ Soil absorption systems shall not be excavated when the soil is wet enough to smear or compact easily. Open soil absorption system excavations shall be protected from surface runoff to prevent the entrance of silt and debris. All smeared or compacted surfaces shall be raked to a depth of one (1) inch, and loose material removed before filter or filler material is placed in the soil absorption system excavation.

~~(formerly 10(a)(ii))—Runoff. Surface runoff shall be diverted around or away from all soil absorption systems.~~

(iii) Soil absorption systems shall be designed to approximately follow the ground surface contours so that variation in excavation depths will be minimized. The trenches may be installed at different elevations, but the bottom of each individual trench shall be level throughout its length.

~~(formerly 10(a)(ix)) (iv) Earth cover. A minimum of 12 inches of earth shall be placed over the absorption system stone. The earth shall be permeable soil that will allow aeration of the system and will support the growth of grass. The earth cover shall be graded to insure that water will not pond on the surface. Shallow soil absorption system depths are encouraged to promote treatment and evapotranspiration. The minimum soil cover depth over the soil absorption system is one (1) foot. The maximum depth to the bottom absorption surface of a soil absorption system is five (5) feet. Finished grading shall prevent ponding and promote surface water runoff.~~

(v) Pipes, chambers or other products shall be bedded on firm, stable material. Heavy equipment shall not be driven in or over soil absorption systems during construction or backfilling.

~~(formerly 10(e)) (vi)——Special requirements for serial sidehill trench or bed systems. Standard trenches refer to perforated pipe embedded in aggregate-filled trenches which shall conform to the following:~~

~~(formerly 10(a)(v))(A) Gravity pipe. All plastic gravity absorption system. The perforated pipes shall have a minimum diameter of four 4 inches and shall conform to ASTM standard D2729. Suitable pipe materials include: ASTM D-2729-11 PVC, ASTM D-3034-08 PVC, Schedule 40 PVC ASTM d1784-11, and ASTM F810-07 PE. Piping in all horizontally constructed absorption systems shall be laid with the holes centered around the vertical axis at the bottom of the pipe. All field tile pipe shall be spaced 1/4 inch apart. Piping in horizontally constructed absorption systems shall have a maximum slope of three inches per 100 feet.~~

~~(formerly 10(a)(iv)) (B)——Stone. Soil absorption system stone. The aggregate shall be crushed rock, gravel or other acceptable, durable and inert material which is free of fines, sized and has an effective diameter between 1/2-inch to 2 1/2 inches. At least two inches of stone shall be placed over the distribution pipe, and at least six inches of stone shall be placed under and beside the distribution piping. A minimum of 12 inches of stone shall be placed between a seepage pit wall and structural liner. The stone shall be free from sand, silt, and clay.~~

~~(formerly 10(a)(viii))(C) Stone cover. A suitable cover such as untreated building paper, filter cloth, or straw shall be placed over the stone prior to backfilling the system. Prior to backfilling, the aggregate shall be covered throughout with a woven/non-woven geotextile material or a three (3) inch layer of straw.~~

(D) Aggregate shall extend the full width and length of the soil absorption system to a depth of at least twelve (12) inches with at least six (6) inches of drain gravel under the distribution pipe and at least two (2) inches over the distribution pipe.

(E) Maximum width of trench excavation is three (3) feet.

~~(formerly 10(d))(F) Special requirements for trench systems. A minimum separation spacing of trenches (wall to wall) of is three (3) feet or a horizontal distance equal to 1.25 times the vertical depth of the trenches, whichever is greater, of undisturbed soil shall be maintained between adjacent trench sidewalls. Trench spacing shall be increased to nine (9) feet when the area between each trench is considered as reserve area. For clay loam soils that have percolation rates slower than 60 min/in., the nine (9) foot spacing shall also be required but it is not considered as reserve area.~~

~~(formerly 10(f))(vii) Special requirement for bed systems. The distribution system piping shall be spaced no more than 10 feet apart. Standard beds shall conform to the same pipe and aggregate requirements for trenches as found in subparagraphs (vi)(A through D) of this section. Standard beds shall also conform to the following:~~

~~(formerly 10(a)(x))(A) The soils shall be absent of clay with percolation rates faster than 60 minutes per inch. Levelness. The bottom of soil absorption systems and each segment of a sidehill system the bed shall must be level, therefore the site shall be relatively flat, sloping no more than one (1) foot from the highest to the lowest point in the installation area.~~

(B) Distribution laterals within a bed must be spaced on not greater than six (6) feet centers. Sidewalls shall be more than three (3) feet from a distribution lateral.

(C) Beds must not be wider than twenty-five (25) feet if gravity distribution is used. Multiple beds must be spaced at one-half the bed width.

(D) Rubber tired vehicles must not be driven on the bottom surface of any bed excavation.

(viii) Chambered trenches, when used in lieu of perforated pipe and aggregate, shall be installed in conformance with the manufacturer recommendations. No cracked, weakened, modified, or otherwise damaged chamber units shall be used in any installation.

(A) All chambers shall be an open, arch-shaped structure of durable, non-degradable design, suitable for distribution of effluent without filter material.

(B) All chamber endplates shall be designed so that the bottom elevation of the inlet pipe is at least six (6) inches from the bottom of the chamber.

(C) Inlet and outlet effluent sewer pipes shall enter and exit the chamber endplates. Inspection ports shall be installed at all outlet effluent sewer pipes.

(D) All chambers shall have a splash plate under the inlet pipe or another design feature to avoid unnecessary channeling into the trench bottom.

(E) Maximum width of trench excavation is three (3) feet.

 (F) Minimum spacing of trenches (wall to wall) is three (3) feet. Trench spacing shall be increased to nine (9) feet when the area between each trench is considered as reserve area. For clay loam soils that have percolation rates slower than 60 min/in., the nine (9) foot spacing shall also be required but it is not considered as reserve area.

(ix) Chambered beds shall conform to the same requirements for chambered trenches as found in subparagraphs (viii)(A through D) of this section. Aggregate, as specified in subparagraph (vi)(B) of this section, or native soil shall be used to fill the space between the chambers.

~~(formerly 10(e)(x) Special requirements for serial sidehill trench or bed systems. Serial sidehill trench:~~

~~(formerly 10(e)(i)) (A) — Separation. A minimum of ~~three~~ six (6) feet of undisturbed soil shall be maintained between adjacent trench or bed side walls.~~

~~(formerly 10(e)(ii)) (B) Levelness. The bottom of each serial trench or bed system shall be level.~~

~~(formerly 10(e)(iii)) (C) The overflow pipe between serial soil absorption systems shall be set no higher than the mid-point of the upstream distribution pipe. The overflow pipe shall not be perforated.~~

~~(formerly 10(b) — Special requirements for seepage pits. If a structural lining is needed to support stone in a seepage pit, it shall be constructed of durable material not subject to excessive corrosion or decay and structurally capable of supporting the loads to which it will be subjected. The lining shall be perforated or otherwise designed to allow the passage of wastewater. Seepage pits shall be separated by a minimum distance equal to 3 times their diameter.~~

(b) A design package for a standard soil absorption system is provided online at the Division's website to assist you in submitting a completed application for a properly designed wastewater treatment and disposal system. The worksheet and calculations were prepared by a registered professional engineer



employed by the Wyoming Department of Environmental Quality, Water Quality Division. The general design requirements stated in this section are incorporated into the worksheets such that by completing the forms, the system will comply with those requirements 

**Section 12. ~~Holding Tanks~~ Pressure Distribution Systems.**

(a) General Design Requirements:

(i) The basic elements of a pressure distribution system include a dosing tank, filter, and a means to deliver specified doses to a small diameter pipe network within a soil absorption system. Pressure distribution is required for mound systems or for bed systems with a width greater than twenty-five (25) feet.

(ii) Pumps must be sized to match the distribution system curve or demand. Pumps shall be designed for sewage pumping applications and be accessible from the ground surface.

(iii) The control system for the pump and dosing tank shall, at a minimum, consist of a “pump off” switch, a “pump on” switch, a “high liquid alarm”.

(A) All electrical connections must be made outside of the chamber in either an approved weatherproof box or an explosion-proof junction box.

(B) The wiring from the junction box to the control box must pass through a sealing fitting to prevent corrosive gases from entering the control panel.

(C) All wires must be contained in solid conduit from the dosing chamber to the control box.

(iv) The pressure transport piping between the tank and the soil absorption system shall be designed to drain after each pump cycle to prevent freezing.

(A) The ends of lateral piping shall be constructed with long sweep elbows or an equivalent method to bring the end of the pipe to finished grade. The ends of the pipe shall be provided with threaded plugs, caps, or other devices to allow for access and flushing of the lateral.

(B) All joints in the manifold, lateral piping, and fittings shall be solvent-welded using the appropriate joint compound for the pipe material. Pressure transport piping may be solvent-welded or flexible gasket jointed.

(C) Where automatic siphons or other devices are used, they shall be designed to empty the dosing tank in less than ten (10) minutes.

~~(formerly 10(a)(vii)) Pressure pipe. All pressure distribution piping shall be designed to withstand the anticipated pressures with a safety factor of two, provide uniform application of the wastewater, and have non-clogging orifices.~~

(b) A design package for a pressure distribution system is provided online at the Division’s website to assist you in submitting a completed application for a properly designed wastewater treatment and disposal

system. The worksheet and calculations were prepared by a registered professional engineer employed by the Wyoming Department of Environmental Quality, Water Quality Division. The general design requirements stated in this section are incorporated into the worksheets such that by completing the forms the system will comply with those requirements.

### **Section 13. ~~Privies~~ Sand Mound Systems.**

The sand mound consists of a sand fill, an aggregate bed and a soil cap. Pressure distribution shall be used in conjunction with sand mound systems.

(a) Selection Criteria:

The high groundwater level, bedrock or impervious clay layer is less than four (4) feet below the level of the soil absorption system excavation.

(b) Site Requirements:

(i) A minimum of one (1) foot of vertical separation of the native soil is required between the bottom of the sand fill and the top of the high groundwater level, any restrictive layer, or any highly permeable material.

(ii) The percolation rate of the native soil at the interface of the sand fill shall be greater than five (5) and less than sixty (60) minutes per inch. The percolation shall be measured in the top twelve (12) inches of native soil.

~~(formerly 10(e)) (c) — Special requirements for mounded systems.~~ General Design Requirements:

~~(formerly 10(c)(i)) — Sizing~~ (i) Sand Layer

(A) Filter sand shall conform to ASTM C-33, with less than 2% passing the #200 sieve.

(B) The minimum depth of sand below the aggregate bed surface shall be one (1) foot.

~~(formerly 10(c)(ii))(C) — Grade. The finished grade shall extend at least three feet horizontally beyond the stone and then be sloped to the parent soil at a grade no steeper than four horizontal to one vertical. The sand mound shall have a combination of at least four (4) vertical feet of filter sand and unsaturated native soil above the high groundwater level.~~

(D) The top of the sand layer under the aggregate bed shall be level in all directions.

(E) The sand layer shall fill around the perimeter of and to the top of the aggregate bed.

(F) The slope of all sides shall be three (3) horizontal to one (1) vertical or flatter.

~~(formerly 10(c)(i)(B))(G) The interface-infiltrative area between the fill soil and the native soil which is the bottom of the sand fill shall be sized-calculated-based-on-the-infiltration-rate-of-the native-soil-as-determined-by-Figure-7-of-Section-38-by-dividing-the-design-flowrates (gpd) from Table 1 or Table 2 by the loading rate (gpd/ft<sup>2</sup>) found in Table 5, but shall not be smaller than a system designed to the requirements of subsection (ii) below.~~

(ii) Aggregate Bed

(A) The aggregate shall be crushed rock, gravel or other acceptable, durable and inert material which is free from fines, and has an effective diameter between one-half (1/2) inch and two and one half (2 1/2) inch.

(B) The aggregate bed depth shall not be less than nine (9) inches with a minimum of six (6) inches of clean aggregate placed below the distribution pipe and two (2) inches above the distribution pipe. The aggregate shall be covered with an approved geotextile material after installation and testing of the pressure distribution system.

(C) The design shall be a long, narrow bed design with a maximum width of twenty-five (25) feet.

(D) The infiltrative area, which is the bottom of the aggregate bed, shall be calculated by dividing the design flowrates (gpd) from Table 1 and Table 2 by the loading rate of 0.8 gpd/ft<sup>2</sup>.

(iii) Soil Cover

(A) The soil cap shall be constructed of a sandy loam, loamy sand, or silt loam. The depth of the soil cap shall be at least six (6) inches at the edges to twelve (12) inches at the center. The slope of all sides shall be three (3) horizontal to one (1) vertical or flatter.

~~(formerly 10(c)(iii))(B) — Fill soil. The fill soil that is—A layer of top soil at least six (6) inches thick shall be placed between the native soil and the stone over the entire sand mound area. shall have a minimum percolation rate of five minutes per inch. Topsoil shall be placed over the mound to promote vegetative cover. The sand mound should be planted with vegetation that does not require watering and will not establish deep roots. Native grasses are commonly used.~~

~~(formerly 10(c)(iv)) Preparation. All trees, roots, and other organic matter shall be removed from the area to be occupied by the mound.~~

(d) A design package for a sand mound system is provided online at the Division's website to assist you in submitting a completed application for a properly designed wastewater treatment and disposal system. The worksheet and calculations were prepared by a registered professional engineer employed by the Wyoming Department of Environmental Quality, Water Quality Division. The general design requirements

stated in this section are incorporated into the worksheets such that by completing the forms the system will comply with those requirements.

#### **Section 14. ~~Chemical Toilets~~ Small Wastewater Lagoons.**

~~(a) — General requirements. Chemical toilets shall only be used in the containment of body wastes. These requirements apply only to the use of chemical toilets for permanent structures.~~

~~— (b) — Greywater. If indoor plumbing is installed, a separate greywater disposal is required and shall meet the requirements of Section 3 through 12. The minimum design flows for greywater shall be obtained from Table 1 with a reduction of 33 percent allowed for the elimination of blackwater wastes.~~

~~— (c) — Disposal. All chemical toilet wastes shall be disposed of at an approved wastewater facility. A letter of verification from the receiving agency, denoting acceptance of the wastewater generated shall be submitted with the plans. These wastes shall not be discharged into a soil absorption system.~~

~~— (d) — Construction. Chemical toilets shall be constructed and installed to resist breakage or damage from routine usage. Outdoor chemical toilets shall be adequately stabilized and secured to prevent overturning. Materials used shall be resistant to the sewage wastes and the chemicals encountered. The holding compartment of the toilet shall be constructed to prevent accessibility to the public and to disease transmitting vectors.~~

~~— (e) — Additives. No chemical or biological additive shall be placed in the toilet that may adversely affect the operation of a sewage treatment facility where the toilet waste will ultimately be disposed or that may adversely impact the quality of the groundwater as specified in Chapter VIII, "Quality Standards for Groundwater of Wyoming."~~

(formerly 15(a))(a) **General requirements. Selection Criteria:**

(formerly 15(a)(i)) (i) ~~The use of this section for small nondischarging waste stabilization ponds applies only to those systems defined as small wastewater systems. All other treatment systems shall meet the requirements of Part B or Part C of Chapter XI as applicable. Lagoons shall only be considered in areas of the State where the annual evaporation exceeds the annual precipitation during the active use of the lagoon.~~

(formerly 15(a)(ii)) (ii) ~~Non-discharging waste stabilization ponds Lagoons shall only be constructed in soils allowed where when the percolation rate exceeds sixty (60) minutes per inch and the soil is at least 1 foot thick on both the sides and bottom of the pond extends vertically down at least two (2) feet from the bottom of the lagoon to the seasonal high groundwater table or bedrock formations. ~~If the 60 minute per inch percolation rate cannot be obtained, a sufficient clay shall be incorporated into the top foot of soil until the 60 minute per inch percolation rate is reached. An impermeable artificial liner of 20 mils in thickness may be substituted.~~~~

(iii) A lagoon shall not be installed on a property less than three (3) acres in size.

(iv) A lagoon shall not be constructed within the 100 year flood plain.

(b) General Design Requirements:

~~(formerly 15(b)) (i) Isolation. The isolation distances shall meet the requirements for absorption systems as specified in Section 4(a)(i). Beyond the horizontal setback distances requirements specified in Section 6(d) of this rule, the lagoon shall not be placed within one hundred (100) feet of the owner's property line.~~

(ii) The use of a septic tank which meets the specifications in Section 9 of this rule shall be required before the small wastewater lagoon.

(iii) The lagoon shall be located and constructed so it will not receive surface runoff water.

(iv) The slope of the lagoon site shall not exceed five (5) percent.

(v) The lagoon site must be located in an area of maximum exposure to sun and wind.

(vi) The lagoon shall be designed for complete retention.

~~(formerly 15(d)) Sizing. (vii)~~ The area of the lagoon shall be calculated based on the following formula.

$$A = \frac{584 \times Q}{(365 \times S) + (E - P) \times 1.3}$$

A = Area of the lagoon at the 5 foot depth water level in square feet

Q = Average daily sewage flow, gallons per day. ~~(0.6 times the flow determined from Table 1)~~ (Multiply values from Table 1 or 2 by 0.6 to get average daily flow.)

E = Average annual lake evaporation rate in inches per year. (Note: lake evaporation is less than pan evaporation; lake evaporation equals pan evaporation times a pan coefficient of about 0.7)

P = Average annual precipitation rate in inches per year.

S = Soil permeability in inches per day "S" cannot be greater than 0.25 inches per day "S" shall equal zero for an artificial liner or for bedrock Seepage rate in decimal form.

~~(formerly 15(e)(i)(viii))~~ The slopes of the ~~inside~~ dikes shall not be steeper than three-(3) horizontal to one(1) vertical ~~nor flatter than four horizontal to one vertical. The slopes of the outside dikes shall not be steeper than three horizontal to one vertical and shall not allow surface runoff to enter the pond. The minimum width of the top of the dike shall be four (4) feet.~~

~~(formerly 15(e)(iii)) (ix)~~ All fill ~~material~~ shall consist of impervious material that is well compacted and free of rocks, frozen soil, or other large material.

(x) The minimum operating depth shall be two (2) feet. The dikes shall provide a minimum freeboard of two (2) feet.

~~(formerly 15(e)(ii)) (xi) All organic material and debris shall be removed from the pond site prior to construction. The floor of the lagoon shall be level and maintained free of all vegetation.~~

(xii) The influent line into the lagoon must discharge near the center onto a concrete apron at least two (2) feet square.

(xiii) A cleanout or manhole shall be provided in the influent line near the dike.

(xiv) The area around the small wastewater lagoon shall be fenced to preclude the entrance of livestock, pets, and humans. The fence shall be equipped with a locking gate. The gate shall have a sign indicating "NO TRESPASSING – WASTEWATER LAGOON".

(c) A design package for a small wastewater lagoon is provided online at the Division's website to assist you in submitting a completed application for a properly designed wastewater treatment and disposal system. The worksheet and calculations were prepared by a registered professional engineer employed by the Wyoming Department of Environmental Quality, Water Quality Division. The general design requirements stated in this section are incorporated into the worksheets such that by completing the forms the system will comply with those requirements.



~~(formerly 15(e)) Groundwater protection and bedrock or impermeable soil separation.~~

~~(formerly 15(e)(i)) For single family homes, the depth to seasonally high groundwater shall be at least four feet from the bottom of pond.~~

~~(formerly 15(e)(ii)) For all "small wastewater systems" other than single family homes, a minimum of three feet of unsaturated soil shall be maintained between the bottom of the pond and the estimated groundwater mound imposed on the seasonally high groundwater table. The height of the groundwater mound can be estimated from Figures 1-6, Section 5 in conjunction with the average daily sewage flow.~~

~~(formerly 15(d)(ii)) A minimum water level of at least two feet shall be maintained in the pond at all times, including start up.~~

~~(formerly 15(d)(iii)) A minimum free board of two feet shall be provided between the lowest embankment berm and the maximum water level. The maximum water level shall not be less than five feet.~~

~~(formerly 15(e)) Construction requirements.~~

~~(formerly 15(e)(iv)) The minimum top width of the dike shall be eight feet.~~

### **Section 15. ~~Small Non-Discharging Waste Stabilization Ponds~~ Privies.**

Pre-fabricated privies and outhouses with sealed, water-tight vaults shall meet the following conditions.

~~(formerly 13(a)) General requirements.~~

~~(formerly 13(a)(ii) If indoor plumbing is installed, the grey water disposal method shall meet the requirements of Section 3 through 12. The minimum design flow for grey water shall be obtained from Table 1 with a reduction of 33 percent allowed for the elimination of black wastes.~~

~~(formerly 13(a)(iii) The privy shall consist of a vault and an outhouse building.~~

~~(formerly 13(b))(a) — Isolation.~~ The isolation requirements for sealed privies shall comply with Section 6(a)(i) for septic tanks.

~~(formerly 13(d)(ii))(b)~~ The depth to seasonally high groundwater from the bottom of a water tight vault shall be sufficient to prevent floatation of the empty vault.

~~(formerly 13(c)) Soil exploration. Soil exploration to a minimum depth of 4 feet below the bottom of the proposed vault shall be made to provide information on subsoil condition.~~

(c) The vault must have sufficient capacity for the dwelling served, and must have at least 27 cubic feet or 200 gallons of capacity.

~~(formerly 13(a)(i))(d) All privies shall be designed and constructed to prevent access by flies and rodents. The privy must be easily maintained and insect tight. The door must be self-closing. The privy seat must include a cover. All exterior openings, including vent openings, shall be screened.~~

~~(formerly 13(d)) Groundwater and bedrock separation.~~

~~(formerly 13(d)(i)) The depth to seasonally high groundwater and bedrock or impermeable soil shall be at least four feet from the bottom of an unlined vault.~~

~~(formerly 13(e)) Sizing. Vaults shall have a minimum capacity of 500 gallons per riser and shall be a minimum of 4.5 feet deep.~~

~~(formerly 13(f)) Construction.~~

~~(formerly 13(f)(i)) The vault shall be constructed and installed to resist breakage and damage imposed by frost heave, uplift pressures from a fluctuating water table, loads imposed by the outhouse building and soils, and damage that may be caused by vandalism or rough cleaning procedures. The vault shall be constructed to prevent access by flies.~~

~~(formerly 13(f)(ii)) Materials used for vault construction shall be resistant to alkali attack, hydrogen sulfide gas, and other corrosive elements associated with decomposing waste.~~

~~(formerly 13(f)(iii)) A clean out manhole shall be installed and shall have a minimum opening of 20 inches in the least dimension. The manhole shall be located outside of the outhouse building and be equipped with a tightfitting secure cover.~~

~~(formerly 13(f)(iv))(e)~~ Privies must be adequately vented. The vault shall be ventilated to a point outside and above the outhouse building. The outhouse building shall have a set of vents installed near the floor on two opposite sides of the building and a roof vent that has a rain cap. All vents shall be screened.



~~(formerly 13(g)) Vault additives. No chemical or biological additive shall be placed in the vault that may adversely effect the operation of a sewage treatment facility where the vault waste will ultimately be disposed or that may adversely impact the quality of the groundwater as specified in Chapter VIII, "Quality Standards for Groundwater of Wyoming".~~

~~(f) Privies shall not be constructed within the 100 year flood plain.~~

#### **Section 16. ~~Commercial/Industrial Wastes. Greywater Systems.~~**

~~(formerly 16 (a)) General requirements. Those requirements listed in Section 1 through 12 and 15 that are applicable to the specific commercial/industrial wastewater or combination of commercial/industrial and domestic wastewater shall apply to this section.~~

~~(formerly 16(b)) Hydrogeologic investigation. If the wastewater is classified as, or determined to be hazardous and/or toxic and/or contain petroleum products, the applicant shall demonstrate to the administrator that any discharge or seepage from the wastewater facility will not cause a violation of the surface and/or groundwaters of the state in accordance with Chapter I, "Quality Standards for Wyoming Surface Waters" and Chapter VIII, "Quality Standards for Wyoming Groundwaters." Due to the wide variety of wastes, wastewater and site conditions, the latest available scientific information shall be used to demonstrate that violation will not occur.~~

~~(formerly 16(c)) Impact. If the impact of the hazardous and/or toxic substance and/or petroleum products cannot be determined and mitigated, disposal of the wastewater using a soil absorption system shall be prohibited.~~

~~(formerly 16(d)) Pre treatment. Pre treatment of the wastewater to remove the hazardous and/or toxic substance(s) and/or petroleum products shall be required prior to disposal if deemed necessary to protect the groundwater of the state. It is the intent of this section to encourage and facilitate the productive and safe reuse of greywater from domestic wastewater.~~

#### (a) Applicability

(i) This section applies to any person who utilizes greywater for beneficial irrigation uses.

(ii) This section is not applicable if the intent is to provide blackwater treatment.

(iii) A city, county, or other local government agency may, after a public hearing and enactment of an ordinance or resolution, further restrict or prohibit the use of greywater systems.

#### (b) Procedure for Estimating Greywater Discharge

(i) The greywater discharge for single family and multi-family dwellings shall be calculated by estimates of greywater use based on water use records, or the following procedure:

(A) The number of occupants of each dwelling unit shall be calculated as follows:

First Bedroom = 2 occupants



Second and subsequent bedrooms = 2 occupants

(B) The estimated greywater flows of each occupant shall be calculated as follows:

Showers, bathtubs and wash basins – 25 GPD/occupant

Laundry – 15 GPD/occupant

(ii) The total number of occupants shall be multiplied by the applicable estimated greywater discharge as provided above and the type of fixtures connected to the greywater system.

(c) Greywater Applications.

(i) General

(A) The total irrigation and/or mulch basin area required, which is the sum of all valved zones, must be equal to the maximum absorption capacity divided by the estimated greywater discharge.

(ii) Subsurface Irrigation

(A) Subsurface irrigation with greywater may be used to irrigate land and vegetation.

(I) Direct human consumption food crops shall not be harvested for 30 days after application of greywater.

(B) Subsurface irrigation shall not surcharge to overland flow.

(I) Direct human consumption food crops shall not be harvested for 30 days after application of greywater.

(iii) Surface Irrigation

(A) Greywater used for surface irrigation shall receive a level of disinfection so the maximum fecal coliform levels is 200/100 ml or less.

(B) Surface irrigation with greywater that has been treated by disinfection may be used for irrigation of land and vegetation.

(iv) Set Backs

(A) A 30 foot buffer zone is required between the greywater application site and adjacent property lines and any public right-of-way when using flood irrigation. This buffer zone requirement may be met by the use of drip irrigation systems.

(B) A 30 foot separation distance is required between greywater application sites and all surface waters.

(C) A 100 foot separation distance is required between greywater application sites and all potable water supply wells.

(d) Greywater Components and Configurations

(i) Flow Diversion

(A) All greywater systems shall have a flow diverter which directs greywater to either the blackwater system or the greywater system.

(B) Diverter valves shall not have the potential to allow backflow from the blackwater system into the greywater system.

(C) Pipe elbows with rotatable compression fittings or equivalent components may be used to connect greywater sources with the greywater system or blackwater system if the pipe can only be connected to one system at a time. A capping device such as a rubber slip cap with band clamp shall be used to seal the plumbing of the system that is not in use.

(D) The rubber discharge hose from a laundry washing machine may be moved between a vertical blackwater riser pipe and a vertical greywater riser pipe without the need for a diverter valve.

(ii) Greywater Collection Tank

(A) When the system design includes a tank, specifications for the tank shall be submitted for approval. Such plans shall show all dimensions and other pertinent data.

(B) Shall be constructed of solid, durable materials not subject to excessive corrosion or decay and shall be water-tight.

(C) Shall be structurally designed to withstand all anticipated earth or other loads. Tank covers shall be capable of supporting an earth load of not less than three hundred (300) pounds per square foot when the tank is used for underground installation.

(D) Shall be covered to prevent access by flying insects, rodents, domestic animals and people.

(E) Shall be vented with a suitable screen to keep animals and insects out of the system.

(F) Inside collection tank shall be installed in accordance with the International Building Code for internal plumbing for black water.

(G) Shall not hold greywater for more than 24 hours.

(H) Overflow Requirements:

(I) Each tank shall have an overflow drain. The overflow drain shall have a permanent connection to the building drain or building sewer, upstream of septic tanks, if any. The overflow drain shall not be equipped with a shutoff valve.

(II) The overflow drain shall not be less in diameter than the inlet pipe.

(III) The overflow system must be designed so that the tank overflow will drain by gravity to the existing sewer line or septic tank. The tank shall be protected against sewer line backflow by a check valve.

(I) Filters:

(I) All discharges from the greywater collection tank shall have suitable filters which retain solids in the greywater collection tank and prevent clogging of the irrigation system.

(II) Shall be accessible for cleaning and maintenance.

(III) Shall be selected based upon expected loading, flow, and pressure.

(J) Each tank shall have its rated capacity permanently marked on the unit. In addition, a sign stating "GREYWATER IRRIGATION SYSTEM, CAUTION – UNSAFE WATER" shall be permanently marked on the holding tank.

(iv) Pumps

(A) Shall be accessible for cleaning and maintenance.

(B) Shall be selected based upon expected flow, pressure and anticipated solids handling according to the overall design.

(C) Shall have a check valve on the discharge of the pump.

(D) Pressurized irrigation systems that are connected to the domestic water system shall have an anti-siphon vacuum breaker installed on the connection to the domestic water system.

(v) Piping

(A) Greywater conveyance pipes shall be permanently labeled for Greywater or shall be colored purple. Non-paint marking pens are unacceptable as permanent labeling.

(B) Gravity flow pipes shall be constructed to allow complete draining of the pipe.

(C) Pressurized pipe systems shall be constructed and designed to be drained or the water evacuated by compressed air for winterization.

(vi) Disinfection

(A) All greywater to be used for surface irrigation shall be disinfected.

(B) Disinfection may be accomplished through chemical methods or ultraviolet disinfection systems.

(I) Chemical disinfection

(1.) Chemical disinfection methods include the use of iodine, chlorine, or bromine.

(2.) Chemical disinfection shall provide the proper dosage of disinfection to achieve a fecal coliform level of 200/100 mL or less.

(II) Ultraviolet disinfection systems

1. Ultraviolet (UV) disinfection systems shall be designed and installed according to the manufacturer's recommendations.

2. Greywater disinfected by a UV disinfection system shall have a UV transmittance less than the UV transmittance rated by the manufacturer.

3. The max flow rate of the UV disinfection system shall not be exceeded.

(vii) Irrigation

(A) General

(I) Irrigation fields may have one or more valved zones. Each zone must be of adequate size to receive the greywater anticipated in that zone.

(II) No irrigation or disposal field shall extend within three (3) vertical feet of the highest known seasonal groundwater, or to a depth where greywater contaminates the groundwater or surface water.

(B) Subsurface Irrigation

(I) Mulch Basins

(1.) Shall be sized to provide sufficient depth, length and width to prevent ponding or runoff during the greywater surge of a clothes washer, bathtub or shower. Mulch shall be replenished as required due to decomposition of organic matter. Mulch basins will require periodic maintenance, reshaping or removal of dirt to maintain surge capacity, to accommodate plant growth, and to prevent ponding or runoff.

(2.) Shall not be deeper than the root zone of the plants to be irrigated.

(3.) Free flow outlets

a. Greywater shall be applied at the top of the mulch.

b. Application point(s) shall be protected from access by flying insects, rodents, domestic animals and people. Protections shall be constructed to allow easy access for cleaning and maintenance.

c. Inlet piping to the mulch basin shall be no less than 1 inch higher than the surface to which it is applied to allow for a free fall of water.

(4.) Sub-mulch outlets

a. Greywater shall be applied below the surface of the mulch into one or more distribution chambers constructed of perforated material.

b. Inlet piping to distribution chamber of the mulch basin shall be no less than 2 inches higher than the surface to which it is applied to allow for a free fall of water.

c. Distribution chamber shall be constructed for easy cleaning and maintenance.

(5.) A compost pile shall meet the requirements of a mulch basin.

(II) Drip systems

(1.) Shall be filtered prior to the point of application or shall be designed to prevent frequent clogging.

(2.) Discharge nozzles shall be specifically designed for the application of greywater without clogging.

(3.) Drilled pipe drip system holes shall be no smaller than ¼" in diameter.

(4.) Point of application flow shall be low enough to prevent any surface flow of greywater.

(III) Permeable pipe systems designed for greywater shall be installed according to manufacturer's recommendations.

(C) Surface Irrigation

(I) Flood irrigation

(1.) Shall not cause channeling or erosion of the application site.  
(2.) Shall use a distribution system to evenly distribute flows across the site.

(3.) Shall not pond in excess of ¼ inch in depth.

(4.) Greywater shall not remain on the ground surface for more than 15 minutes after source flow has stopped.

(II) Spray Irrigation

(1.) Spray irrigation of greywater is not permitted.

(g) Greywater Operation and Requirements

(i) Restrictions

(A) The installation of a greywater system shall not reduce or alter the sizing requirements of the onsite wastewater system.

(B) Human, domestic pets, and animal contact with greywater and soil irrigated with greywater shall be minimized.

(C) Greywater shall not leave the property on which it is generated. Ponding or runoff is prohibited.

(D) Water which has been used to wash diapers or similarly soiled or infectious garments shall not enter the greywater system and shall be diverted into the sanitary sewer or septic system.

(E) Water which contains hazardous materials such as paint, solvents, petroleum products, oil, gasoline, antifreeze, solvents, pesticides and herbicides shall not enter the greywater system. Greywater shall not contain hazardous chemicals derived from activities such as cleaning car parts, washing greasy or oily rags, or disposing of wastewater solutions from home photo labs or similar hobbyist or home occupational activities.

(F) Greywater systems shall not be installed in a delineated floodplain.

(G) The volume of greywater shall not exceed an average of 2000 gallons per day.

(H) Greywater shall not come in direct contact with or adversely impact surface or groundwater.

(I) The filter backwash and flush discharge shall be contained and disposed of into the building sewer system or septic tank with a design capacity to accept all the blackwater and greywater. Filter backwash water and flush water shall not be used for any purpose. Sanitary procedures shall be followed when handling filter backwash and flush discharge or greywater.

(ii) Odor Control

(A) Odor control of the greywater system shall meet the requirement of Wyoming DEQ Air Quality Regulations Chapter 2, Section 11.

(iii) Stormwater

(A) The greywater system shall not be located in a drainage way.

(B) The greywater system shall prevent storm runoff from carrying the greywater off the application site.

(iv) Winter Operation

(A) If the greywater system is to be used during the winter, the greywater system shall be designed to prevent freezing.

**Section 17. Operation and Maintenance.**

(a) For any system that disposes of wastewater through land application or subsurface filtration, the owner shall not add any chemical or biochemical additive to the system that would adversely affect the quality of the groundwater as stated in the WDEQ Water Quality Rules & Regulations, Chapter VIII.

(b) Septic tanks shall be pumped as needed to prevent solids carryover into the soil absorption system.

(c) Holding tanks and sealed vaults shall be pumped prior to reaching their maximum capacity. It is preferable that these types of tanks be pumped before the wastewater volume exceeds 75% of the tank's capacity.

(d) Any service provider that pumps septic tanks, holding tanks, or sealed vaults, shall dispose of the wastewater contents at a permitted wastewater treatment facility or in a manner approved by the Division or delegated authority.

(e) Damaged fittings and broken, crushed or plugged piping associated with any small wastewater system shall be replaced in a timely manner.

(f) Composting or non-discharging toilets where permitted shall have their waste disposed of at a permitted wastewater treatment facility or landfill, or in a manner approved by the Division or delegated authority.

APPENDIX A  
Percolation Test Procedure

Section 1. Purpose

(a) Percolation tests are used to determine absorption system site suitability and to size the absorption system.

Section 2. Procedure

~~(formerly (a)) (a) Location. General Requirements: The percolation test holes shall be spaced uniformly over the proposed absorption field site. A minimum of three test holes are required.~~

(i) Percolation tests shall not be conducted in test holes which extend into groundwater, bedrock, or frozen ground.

(ii) The percolation test shall be conducted only after the soil exploration pit has been dug and examined.

(iii) A minimum of three (3) percolation test holes are required.

(iv) The percolation test holes shall be spaced uniformly over the proposed soil absorption system site.

~~(formerly (b)) (b) Preparation. A 4 inch to 12 inch hole shall be dug or bored to the proposed depth of the absorption field. The walls shall be vertical. To expose a natural soil surface, the sides and bottom shall be scraped with a sharp pointed instrument and the loose material shall be removed from the hole. Coarse sand or gravel shall be placed in the bottom of the hole to prevent it from scouring and sealing.~~

(i) A four (4) inch to twelve (12) inch diameter hole shall be dug or bored to the proposed depth of the soil absorption system.

(ii) The walls shall be vertical, with the natural soil surface exposed without smearing.

(iii) ~~To expose a natural soil surface~~ The sides and bottom shall be scarified with a sharp pointed instrument and the loose material shall be removed from the hole.

(iv) Two (2) inches of gravel or coarse sand shall be placed in the bottom of the hole to prevent it from scouring and sealing during water addition.

(c) Presoaking

~~(formerly (c)) (i) — Presoaking.~~ The purpose of presoaking is to have the water conditions in the soil reach a stable condition similar to that which exists during continual wastewater application. The minimum time of presoaking varies with soil conditions but must be sufficiently long so that the water seeps away at a constant rate. The following presoaking



instructions are usually sufficient to obtain a constant rate.

~~(formerly (c)(i)) (A)~~ In sandy soils, place 12 inches of water in the hole. Fill each hole with clear water to a level at least 18 inches above the gravel or coarse sand and allow it to seep away. Fill the hole again with 12 inches of water and if the water seeps away in ten minutes or less, it indicates that the soil is excessively permeable and requirements in Section 5(d) of these regulations shall be followed. If the 18 inches of water seeps away in 18 minutes or less, add 18 inches of water a second time. If the water remains after ten minutes, additional saturation is necessary. Refer to Appendix A(c)(ii) below. If the second filling of 18 inches of water seeps away in 18 minutes or less, this indicates the soil is sandy and is excessively permeable. The soil absorption system shall meet the requirements of Section 7 (c).

~~(formerly (c) (ii)) (B)~~ In other soils, maintain 12 inches of water in the hole for at least four hours. If either the first or second fillings of 18 inches of water does not seep away in 90 minutes, 18 inches of water must be maintained in the hole for at least 4 hours to presoak the test hole. After the four hours of water contact time, allow the soil to swell for wait-12 hours-before starting the percolation rate measurement-as stated in Appendix A (d) below.

~~(formerly (d) (d))~~ Percolation rate measurement ~~—The water level should be adjusted to six inches above the gravel initially and after each time interval measurement when necessary.~~

~~(formerly (i))(i)~~ In other soils, establish a fixed reference point and measure the drop in water level at constant intervals. The water level drop should be measured to the nearest 1/8 of an inch. The test may be terminated when the water drop is consistent for three consecutive measurements. Fill each test hole with 12 inches of water and allow the soil to rehydrate for 15 minutes prior to any measurements

(ii) Establish a fixed reference point to measure the incremental water level drop at constant time intervals. The water level drop should be measured to the nearest 1/8 of an inch and the minimum time interval is ten (10) minutes.

(iii) Refill the test hole to 12 inches above the gravel before starting the measurements. Continue to measure the incremental water level drop at a constant time interval until a consistent incremental water level drop is achieved. A consistent water level drop is achieved when three (3) consecutive water level drops are within 1/8 inches of each other.

(iv) Before the water level drops below 6 inches above the gravel, refill the test hole to 12 inches and continue to measure the incremental water level drop.

~~(formerly d(ii))(v)~~ The percolation rate ~~for each hole~~ is calculated ~~as follows~~ for each hole using the following formula:

$$\begin{array}{l} \text{Time Interval (Minutes)} \\ \text{Final Water Level Drop (inches)} \end{array} = \begin{array}{l} \text{Percolation Rate} \\ \text{(minutes/inch)} \end{array}$$

~~(formerly d(ii))(vi)~~ If only three to five percolation tests are performed, the

design percolation rate for the absorption system is the slowest rate from all the holes tested. If six or more percolation tests are performed, the design percolation rate for the absorption system is the average of all the holes tested as determined by the above formula.

(e) The following information shall be recorded:

(i) Date(s) of test(s);

(ii) Location, diameter, and depth of each test hole;

(iii) Duration of presoak;

(iv) Time of day for beginning and end of each water-level drop interval;

(v) Each water-level drop measurement;

(vi) Calculated percolation rate;

(vii) Name and signature of person performing test;

(viii) Name of owner or project name;

(ix) Certification that the percolation test was done in accordance with Wyoming Water Quality Rules and Regulations Chapter 25 Appendix A.

APPENDIX B  
Land Application of Domestic Septage in Remote Areas

Section 1. Restrictions and Requirements

To qualify for the land application of domestic septage in remote areas, the following conditions must be met.

(a) Location restrictions shall adhere to the following:

(i) Domestic septage generated on a specific property may be land applied on said property, and shall not be transported to another location for land application.

(ii) No land application of domestic septage shall occur within 1,000 feet of all adjacent properties.

(iii) No land application of domestic septage shall occur within 300 feet of a public road, permanent surface water body, or intermittent stream.

(b) Site restrictions shall adhere to the following:

(i) The land application of domestic septage shall only occur on those sites with established vegetation such as rangeland, pasture or hay meadows.

(ii) No more than 5,000 gallons of domestic septage per acre per year shall be land applied.

(iii) No land application of domestic septage shall occur where the site's slope exceeds five percent (5%) or where the depth to groundwater is less than four (4) feet.

(iv) The land application of domestic septage shall not occur between November 1 and May 1, or any other time when frozen or saturated ground conditions exists.

(v) No public access shall be allowed for one (1) year to any site where domestic septage has been applied.

(vi) No grazing animals shall be allowed access for 30 days to any site where domestic septage has been land applied.

(c) Crop restrictions shall adhere to the following:

(i) No root crops shall be harvested for 38 months from soils where domestic septage has been land applied.

(ii) No truck crops (harvested parts touch land surface) shall be harvested for 14 months from soils where domestic septage has been land applied.

(iii) No commodity crops (other food, feed, and fiber crops whose harvested parts do not touch land surface) shall be harvested for 30 days from soils where domestic septage has been land applied.

(iv) No turf shall be harvested for one (1) year from soils where domestic septage has been land applied.

(d) Reporting requirements:

(i) The property owner shall notify the appropriate Department of Environmental Quality, Water Quality Division (DEQ/WQD) District Engineer prior to the land application of domestic septage to confirm the requirements and to arrange a possible DEQ/WQD inspection of the land application.

(ii) All records concerned with each septage application will be maintained for at least five (5) years.

(iii) There is a worksheet online that must be completed, signed and returned to the DEQ/WQD or the appropriate delegated local permitting authority within 15 days of the land application.

"QUALITY PUMPS SINCE 1939"



SECTION: 3.20.145

FM1730

0205

Supersedes

0604

Product information presented here reflects conditions at time of publication. Consult factory regarding discrepancies or inconsistencies.

MAIL TO: P.O. BOX 16347 • Louisville, KY 40256-0347  
SHIP TO: 3649 Cane Run Road • Louisville, KY 40211-1961  
(502) 778-2731 • 1 (800) 928-PUMP • FAX (502) 774-3624

visit our web site:  
[www.zoeller.com](http://www.zoeller.com)

# ZOELLER ON-SITE WASTEWATER PRODUCTS

## INTRODUCING THE TRU-FLOW SPLITTER SYSTEM



Patent No. 6,112,766  
and 6,152,650

4" riser easily attaches to visually inspect and adjust the diverter.

Sturdy polypropylene box to withstand frost heaves, heavy loads, and corrosion.

Bubble level included for quick and easy installation and service.

Can be field adapted from 2 to 5 outlets.

Diverter can accurately split gravity flows down to 1/10 gpm and pumped flows up to 30 gpm such as enhanced flow or flood dose systems.

Lightweight for quick and easy installations.

### ORDER NUMBERS:

P/N 173-0001 - Tru-Flow Splitter System (Standard with 4" Schedule 35 pipe seals)

P/N 173-0005 - 3" pipe seals.  
(order in addition to 173-0001.)

P/N 173-0006 - 4" Schedule 40 pipe seals.  
(order in addition to 173-0001.)

P/N 173-0007 - Zoeller 6" diameter x 36" tall riser for splitter system. Used on deep installations to aid in diverter adjustment. Height is field adjustable.

### Splitter System

This innovative Splitter System will evenly split effluent into two to five lines. It is made of two major parts: (1) the diverter basin & cover and (2) the diverter. The patented bubble level design allows for post construction adjustability and maintenance, thereby solving the problems associated with distribution box settlement. The Tru-Flow® unit may settle as much as 15° front-to back (30° total) and/or 12° side-to-side (24° total) and, when adjusted, will evenly split effluent. The Splitter System works with low flows as well as high flows. This unique design has no parts to wear out and utilizes corrosion resistant materials.



# Technical Specifications

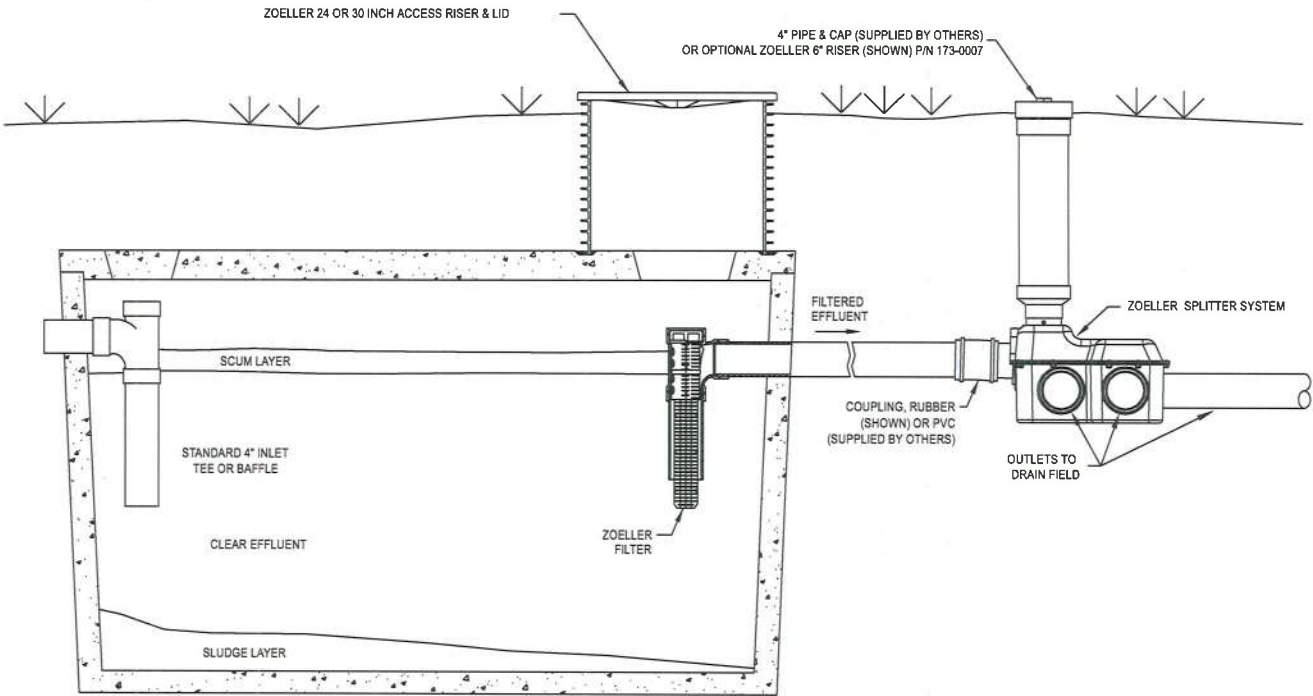

SK1975

**SAMPLE ENGINEERING SPECIFICATION:**

CONTRACTOR must furnish a Zoeller Tru-Flow® splitter system, model 173-0001. A concrete or plastic distribution box requiring speed levelers should not be considered equal. The assembled splitter system must be lightweight to ease the burden of installation. Product must be capable of splitting effluent from 1/10th to 30 gpm evenly into 2 to 5 distribution lines. Product must not require external water for distribution line flow balancing purposes. System must be maintainable from the surface. Bubble level will be built in for easy adjustments and service. A 4" or 6" riser pipe shall be brought to the surface for future access, inspection, and adjustment. Splitter housing shall be rigid enough to withstand the anticipated frost and traffic loading. The splitter system must be made of all non-corrosive materials. Housing shall be made of polypropylene to increase the chemical resistance to the effluent and gases present in the waste stream. Diverter shall be made of virgin ABS to enhance product life. Six 4" SDR 35 pipe seals shall be provided with the unit.

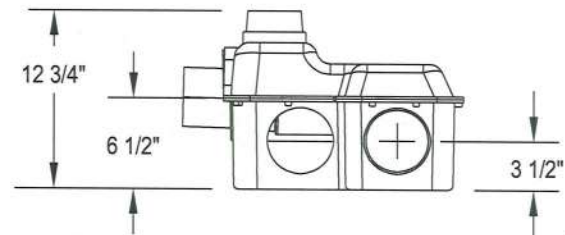
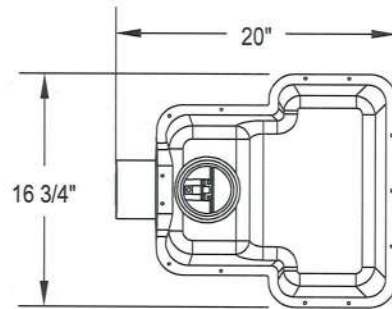

SK1976

ALL ZOELLER ONSITE PRODUCTS MUST BE INSTALLED IN ACCORDANCE WITH PLUMBING AND HEALTH DEPARTMENT CODES.

**Distributed By:**



1-800-928-PUMP  
www.zoeller.com



---

**Fwd: Comments Chapter 25**

1 message

---

**William Tillman** <william.tillman@wyo.gov>

Fri, May 17, 2013 at 11:17 AM

To: Gina Johnson <gina.johnson@wyo.gov>, Frank Strong <frank.strong@wyo.gov>

----- Forwarded message -----

From: **Steve Warner** <[steve.warner@fremontcountygovernment.org](mailto:steve.warner@fremontcountygovernment.org)>

Date: Thu, May 16, 2013 at 11:54 AM

Subject: Comments Chapter 25

To: [bill.tillman@wyo.gov](mailto:bill.tillman@wyo.gov)

Bill -

I have included my comments regarding the latest draft of Chapter 25. I have also enclosed a cut sheet for the Zoeller distribution box as it relates to my comments. Thank you for the opportunity to comment.

*Steve Warner*

**Small Wastewater Specialist**

Fremont County Planning

Rm. 360 Courthouse

450 N. 2nd St.

Lander, WY 82520

Ph: (307) 332-1078

Cell: (307) 330-8203

email: [steve.warner@fremontcountygovernment.org](mailto:steve.warner@fremontcountygovernment.org)

--  
William Tillman, P. E.  
Water and Wastewater Section  
Regulatory and Enforcement  
Herschler Building, 4-W  
122 West 25th Street  
Cheyenne, WY 82002  
(307) 777-6941  
(307) 777-6779 (FAX)  
[william.tillman@wyo.gov](mailto:william.tillman@wyo.gov)

"I'm like there's no tomorrow. One day you'll be right!"

Live like there's no tomorrow. One day you'll be right

## Ch 25 Public Notice Comments for 6-14-13 WWAB Meeting 64

E-Mail to and from me, in connection with the transaction of public business, is subject to the Wyoming Public Records Act and may be disclosed to third parties.

---

### 2 attachments

 **20130426Ch25STRIKE UNDERLINE.pdf**  
431K

 **Zoeller D-box.pdf**  
298K



Chapter 25  
SMALL WASTEWATER SYSTEMS

Table of Contents

Section 1.	<del>General Authority</del> .....	25-1
Section 2.	<del>Definitions</del> <u>Objective</u> .....	25-1
Section 3.	<del>Design Flows</del> <u>Definitions</u> .....	25-1
Section 4.	<del>Isolation</del> <u>Design Flows</u> .....	25-4
Section 5.	<del>Site Suitability</del> <u>Systems not Specifically Covered by these Standards</u> .....	25-5
Section 6.	<del>Building Sewer Pipes</del> <u>Site Suitability</u> .....	25-6
Section 7.	Soil Absorption System Sizing .....	25-14
Section 8.	<del>Pretreatment</del> <u>Building Sewer Pipes</u> .....	25-16
Section 9.	<del>Dosing Systems Following Septic Tanks</del> <u>Septic Tanks and Other Treatment Tanks</u> .....	25-16
Section 10.	<del>Subsurface Treatment and Disposal Systems</del> <u>Effluent Distribution Devices</u> ..	25-22
Section 11.	<del>Evapotranspiration Beds</del> <u>Standard Soil Absorption Systems</u> .....	25-23
Section 12.	<del>Holding Tanks</del> <u>Pressure Distribution Systems</u> .....	25-25
Section 13.	<del>Privies</del> <u>Sand Mound Systems</u> .....	25-26
Section 14.	<del>Chemical Toilets</del> <u>Small Wastewater Lagoons</u> .....	25-28
Section 15.	<del>Small Non-discharging Waste Stabilization Ponds</del> <u>Privies</u> .....	25-30
Section 16.	<del>Commercial/Industrial Wastes</del> <u>Greywater Systems</u> .....	25-30
<u>Section 17</u>	<u>Operation and Maintenance</u> .....	25-37
APPENDIX A	<u>Percolation Test Procedure</u> .....	A-1
<u>APPENDIX B.</u>	<u>Land Application of Septage</u> .....	B-1

## CHAPTER 25

## SMALL WASTEWATER SYSTEMS

**Section 1. ~~General~~ Authority.**

This rule is promulgated pursuant to Wyoming Statutes (W.S.) 35-11-101 through 35-11-1701, specifically 35-11-302(a)(iii).

**Section 2. ~~Definitions~~ Objective.**

~~(formerly Section 1) This part Chapter contains the minimum standards for the design and construction of sewerage small wastewater systems, treatment works and disposal systems for domestic wastes and industrial wastes generated by facilities other than specifically covered by other parts of this Chapter which are defined by W.S. 35-11-103(c)(ix). The two thousand (2,000) gallons defined in the statute shall be the average flow of domestic sewage per day.~~

A Wyoming registered professional engineer (PE) will be required when small wastewater systems are proposing to use an Advanced Treatment process, encounter high strength wastewater, or propose a standard soil absorption system when the soil percolation rate is over 60 minutes per inch (mpi).

**Section 3. ~~Design Flows~~ Definitions.**

~~(a) "Absorption system" means a system constructed under the surface of the ground which receives and distributes effluent from a pretreatment device effectively filtering the effluent through soil or media. "Absorption surface" means the interface where treated effluent infiltrates into native or fill soil.~~

~~(b) "Aerobic unit" means a covered, watertight receptacle which receives wastewater. The unit removes settleable solids, floatable material, and a part of soluble organic matter by the use of aerobic biological treatment. "Advanced treatment" means a treatment process that achieves an effluent being discharged to the absorption surface or native soil with a BOD<sub>5</sub> less than or equal to 100 mg/L.~~

~~(c) "Building drain" means the building drain is that part of the lowest piping of a drainage system which receives the discharge from soil, waste and other drainage pipes inside the walls of the building and conveys it to the building sewer beginning two feet (.6m) outside the building wall. "Bed" means a soil treatment and dispersal system where the width is greater than three (3) feet.~~

~~(d) "Building sewer" means the building sewer is that part of the horizontal piping of a drainage system which extends from the end of the building drain and conveys the building drain discharge to the septic tank or other onsite sewage disposal facility. "Bedrock" means geological layers, of which greater than 50 percent by volume consist of unweathered in-place consolidated rock or rock fragments. Bedrock also means weathered in-place rock which cannot be hand augered or penetrated with a knife blade.~~

~~(e) "Domestic sewage" means the liquid and waterborne wastes derived from the ordinary living processes, free from industrial wastes, and of such character as to permit satisfactory disposal without special treatment. "Bedroom" means any room that is or may be used for sleeping.~~

(f) ~~“Dosing system” means the system of tanks, pumps or syphons, and piping located between the septic tank and soil absorption system which is intended to apply a large quantity of settled wastewater to the absorption system in a short period of time.~~ “Blackwater” means water containing fecal matter and/or urine.

(g) ~~“Hydrogeological study” means a study of the occurrence, distribution, quality and movement of the shallowmost groundwater of the site and the potential impact of wastewaters on the groundwater.~~ “Five Day Biochemical Oxygen Demand (BOD<sub>5</sub>)” means a measurement of the dissolve oxygen used by microorganisms in the biochemical oxidation of organic matter during a five (5) day period.

(h) ~~“Impermeable soil” means any soil which has a percolation rate greater than 60 minutes per inch.~~ “Building sewer” means the the pipe which carries wastewater from the building.

(i) ~~“Pump Tank” means a tank in which the dosing pumps or syphons are installed.~~ “Chamber” means a domed open bottom structure that is used in lieu of perforated distribution pipe and gravel media.

(j) “Delegated small wastewater program” means a local governmental entity, delegated by the Administrator, with the authority to administer the provisions of W.S. 35-11-301(a) (iii) for small wastewater systems pursuant to the provisions of W.S. 35-11-304.

(k) “Direct human consumption food crops” are crops consumed directly by humans. These include, but are not limited to fruits, vegetables and grains grown for human consumption.

(l) “Domestic wastewater” means a combination of the liquid or water-carried wastes from residences, business buildings, institutions, and other establishments arising from normal living activities.

(m) “Domestic Septage” means liquid or solid material removed from a waste treatment vessel that has received only wastes from residences, business buildings, institutions, and other establishments arising from normal living activities.

(n) “Dosing tank” means a tank equipped with an automatic siphon or pump designed to discharge effluent on an intermittent basis.

(o) “Effluent” means a liquid flowing out of a septic tank, other treatment vessel or system.

(p) “Effluent filter” means a removable, cleanable device inserted into the outlet piping of a septic tank or other treatment vessel designed to trap solids that would otherwise be transported to the soil absorption system or other downstream treatment components.

(q) “Evapotranspiration” means the combined loss of water from soil by evaporation from the soil or water surface and by transpiration from plants.

(r) “Greywater” means untreated wastewater that has not been contaminated by any toilet discharge, which is unaffected by infectious, contaminated, or unhealthy bodily wastes, and does not present a threat from contamination by unhealthful processing, manufacturing, or operating wastes. “Greywater” includes but is not limited to wastewater from bathtubs, showers, bathroom, washbasins, clothes washing machines (unless soiled diapers are serviced), laundry tubs, and kitchen sinks.

(s) “Grease interceptor” means a device designed to separate fats, oils, and grease from the wastewater.

(t) “Groundwater” means subsurface water that fills available openings in rock or soil materials such that they may be considered water saturated under hydrostatic pressure.

(u) “High groundwater” means seasonally or periodically elevated levels of groundwater.

(v) “High Strength Wastewater” means a wastewater stream with a BOD<sub>5</sub> higher than 200 mg/l.

(w) “Holding Tank” means a watertight receptacle designed to receive and store wastewater.

(x) “Manifold” means a non-perforated pipe that distributes effluent to individual distribution pipes.

(y) “Mound system” means an onsite wastewater system where the bottom of the absorption surface is above the elevation of the existing site grade, and the absorption surface is contained in a mounded fill body above the grade.

(z) “Mulch basin” basin means an excavated area that has been refilled with a highly permeable media, organic and inorganic materials intended to distribute greywater to irrigate vegetation.

(aa) “Percolation Rate” means the time expressed in minutes per inch required for water to seep into saturated soil at a constant rate during a test.

(bb) “Pipe Invert” means the bottom or lowest horizontal point of the internal surface of the pipe.

(cc) “Percolation test” means the method used to measure the percolation rate of water into soil as described in Appendix A.

(dd) “Pressure distribution” means a network of pipes in which effluent is forced through orifices under pressure.

(ee) “Pretreatment” means any technology or combination of technologies that precedes discharge to a soil absorption system or other final treatment unit or process before final dissemination into the receiving environment.

(ff) “Restrictive layer” means a nearly continuous layer that has one or more physical, chemical, or thermal properties that significantly impede the movement of water and air through the soil or that restrict roots or otherwise provide unfavorable root conditions. Examples are bedrock, cemented layers, dense layers, and frozen layers.

(gg) ~~(formerly defined in Section 5(e)(ii))~~ “Saturated Thickness” means the distance between the seasonally high groundwater table and the under-lying impervious layer such as clay, bedrock or soils with significantly lower permeability.

(hh) “Septic tank” means a buried, watertight tank designed and constructed to receive and treat raw wastewater.

(ii) “Service provider” means a person authorized and trained by a system manufacturer or their vendor to operate and maintain any proprietary system which provides advanced treatment.

(jj) “Soil absorption system” means a shallow, covered, excavation made in unsaturated soil into which pretreated wastewater is discharged through distribution piping for application onto absorption surfaces through porous media or manufactured components placed in the excavations.

(kk) “Trench” means an absorption surface with a width of three (3) feet or less.

**Section 4. Isolation Design Flows.**

~~(formerly Section 3) The sewerage system, treatment works and disposal system shall have a minimum absorption area based on the minimum peak design flows listed in Table 1 below. The quantity of wastewater shall be determined by one of the following:~~

- (a) Tables 1 and 2 provided in this section.
- (b) Metered water supply data from the facility.
- (c) Metered water supply data from another facility where similar water demands have been demonstrated.

**Table 1**

**Quantities of Domestic Sewage Flows**

Type of Establishment	Flow (gallons per day per _____)
<b>Residential Units</b>	
Single Family Dwellings	150/bedroom
Multiple Family Dwelling (with laundry capabilities)	150/bedroom
Multiple Family Dwelling (without laundry capabilities)	120/bedroom
Cottages	50/person
Mobile Home Parks	350/home*
<b>Commercial Facilities</b>	
Airports	4/passengers
Bar	3/patron
Bathhouses and swimming pools	10/person
Campgrounds (individual sewer outlets available)	100/site
Campgrounds (service building only)	75/site
Car or truck wash	200/vehicle
Church (no food preparation and/or dishwashing)	5/seat
Church (food preparation and/or dishwashing)	7/seat
Country Club	100/member
Factories	30/employee
Hospital	200/bed
Laundry (self-service)	600/machine or 50/cycle
Motels	80/double bed or 40/single bed
Office building	30/employee
Restaurant (toilet and kitchen wastes)	13/meal

Restaurant (kitchen wastes)	6/meal
Restaurant (additional for bars and lounges)	2/meal
Restaurant (kitchen wastes with disposable service)	2/meal
Rest Home	100/resident
Schools Boarding	100/resident student
Day, without gyms, cafeterias, or showers	15/student
Day, with cafeterias only	20/student
Day, with cafeteria, gym and showers	25/student
Service stations	10/vehicle served
Shopping Center	2/parking space
Store, Retail	30/employee
Theaters: Movie	5/seat
Drive In	15/vehicle space
Warehouses	30/employee

\* Must consider flow into the soil absorption system from mobile homes where taps are allowed to run to prevent freezing.

**Table 1. Residential Design Flow Rates per Bedroom (gallons per day, gpd)<sup>1</sup>**

<a href="#">1 bedroom</a>	<a href="#">150</a>
<a href="#">2 bedrooms</a>	<a href="#">280</a>
<a href="#">3 bedrooms</a>	<a href="#">390</a>
<a href="#">4 bedrooms</a>	<a href="#">470</a>
<a href="#">5 bedrooms</a>	<a href="#">550</a>
<a href="#">6 bedrooms</a>	<a href="#">630</a>

<sup>1</sup>An unfinished basement is considered two (2) additional bedrooms.

<sup>2</sup>The design flow shall be increased by eighty (80) gpd for each additional bedroom over six (6).

**Table 2. Non-Residential Wastewater Design Flow Rates<sup>1</sup>**

Facility	Unit	Flow (gallons/unit/day)
Airports	<a href="#">person</a>	4
<a href="#">Apartment</a>	<a href="#">bedroom</a>	<a href="#">120</a>
<a href="#">Automobile</a> Service Station	vehicle served	10
Bars	<a href="#">seat</a>	<a href="#">20</a>
Bathhouses and swimming pools	person	10
Campgrounds ( <a href="#">w/ toilets only</a> )	<a href="#">person</a>	<a href="#">25</a>
Campgrounds ( <a href="#">w/shower facility</a> )	<a href="#">person</a>	<a href="#">45</a>
<a href="#">Church</a>	<a href="#">person</a>	4

Country Club		member	<u>25</u>
<u>Day School, Office building, Retail Store, Warehouse (no showers)</u>		<u>person</u>	<u>15</u>
Hospital		bed	<u>250</u>
<u>Industrial Building (sanitary waste only)</u>		<u>employee</u>	<u>20</u>
Laundry (self-service)		<u>machine</u>	<u>450</u>
Mobile Home		<u>each</u>	<u>70</u>
Motel, <u>Hotel, Resort</u>		<u>bedroom</u>	<u>140</u>
<u>Recreational Vehicle</u>		<u>each</u>	<u>100</u>
Rest Home, <u>Care Facility, Boarding School</u>		bed	100
Restaurant		meal	<u>10</u>
Theater		<u>seat</u>	<u>3</u>

<sup>1</sup>Values shown in the above table are the typical flowrates from Wastewater Engineering Treatment and Reuse, Metcalf & Eddy, 2003 Edition.

#### **Section 5. ~~Site Suitability~~ Systems not Specifically Covered by this rule.**

This section is provided to encourage new technology and equipment and provide a process for evaluating and permitting designs which deviate from this rule. The proposed construction of facilities and processes not in compliance with this rule will be permitted provided that the facility, when constructed, can operate meeting the purpose of these rules.

(a) Each application for a permit to construct shall include an engineering design report, detailed construction plans, and technical specifications for all piping, tanks, and equipment. All of the documents shall have a suitable title showing the owner's name and the Wyoming registration number, seal, and signature of the engineer.

(b) Each application for a permit to construct will be evaluated on a case-by-case basis using the best available technology. The application shall include at least one of the following:

(i) Data obtained from a full scale, comparable installation which demonstrates the acceptability of the design.

(ii) Data obtained from a pilot plant operated under the design condition for a sufficient length of time to demonstrate the acceptability of the design.

(iii) Data obtained from the theoretical evaluation of the design which demonstrates a reasonable probability of the facility meeting the design objectives.

(iv) An evaluation of the flexibility of making corrective changes to the constructed facility in the event it does not function as planned



(c) If an applicant wishes to construct a pilot plant to provide data necessary to show the design will meet the purpose of the act, a permit to construct must be obtained.

## **Section 6. Building Sewer Pipes Site Suitability.**

~~Formerly 4(e)(a)~~ **Location.** Locate the small wastewater system where the surface drainage is good. Avoid depressions and bases of slopes and areas in the path of runoff from roofs, patios, driveways, or other paved areas unless surface drainage is provided. ~~Absorption systems~~ Small wastewater systems shall not be located beneath buildings, parking lots, roadways, driveways, irrigated landscaping or other similarly compacted areas.

~~(formerly 10(a)(i)(b)~~ **Replacement area.** ~~An area shall be designated and shown on the plans for future installation of a replacement absorption system. The site must be large enough to include area for a future replacement soil absorption system. Both the proposed and replacement soil absorption systems shall be sized to receive one-hundred (100%) percent of the wastewater flow. If a trench system is used, the replacement area soil absorption system may include the area be located between the trenches of the proposed soil absorption system if sufficient spacing has been provided there is at least nine (9) feet of spacing between trench sidewalls. At least three feet of undisturbed soil shall remain between the existing and replacement trench side walls.~~

(c) For standard soil absorption system, effective suitable soil depth shall extend at least four (4) feet below the bottom of the soil absorption system to any restrictive layer or highly permeable material.

~~(formerly 5(e)) (d) ——— Groundwater protection and bedrock or impermeable soil separation. The depth of the high groundwater shall be at least four (4) feet below the bottom of the absorption surface. (formerly 5(e)(ii)) — For all systems other than single family homes up to 2000 gallons per day, the depth to bedrock or impermeable soil must be at least four feet from the natural ground surface. The depth to seasonally high groundwater must be at least four feet from the bottom of the absorption system stone and at least two feet from the natural ground surface. Also, a minimum of three (3) feet of unsaturated soil shall be maintained between the bottom of the absorption system stone surface and the estimated groundwater mound imposed on the seasonally high groundwater table. The height of the groundwater mound may be estimated from Figures 1 through 6. The average daily flow should be used and may be estimated as 0.6 times the flow determined from Tables 1 and 2. In areas of high groundwater, this vertical separation requirement is most commonly satisfied by a mound and pressure dosed soil absorption system.~~

~~(formerly 5(e)(i)) For single family homes, the depth to bedrock or impermeable soil must be at least four feet from the bottom of the absorption system stone and the natural ground surface. The depth to seasonally high groundwater must be at least four feet from the bottom of the absorption system stone and at least two feet from the natural ground surface.~~

~~(formerly 5(e)(iii)) For all systems larger than 2000 gallons per day, a minimum of three feet of unsaturated soil shall be maintained between the bottom of the absorption system stone and the estimated groundwater mound imposed on the seasonally high groundwater table. The maximum height of the groundwater mound shall be estimated by the design engineer.~~

~~(formerly 5 (e)(ii)) “Estimated Rise in Water Table”: The estimated distance the water table will rise at the center of the absorption system above the initial water table when the indicated flow is applied daily.~~



DRAFT

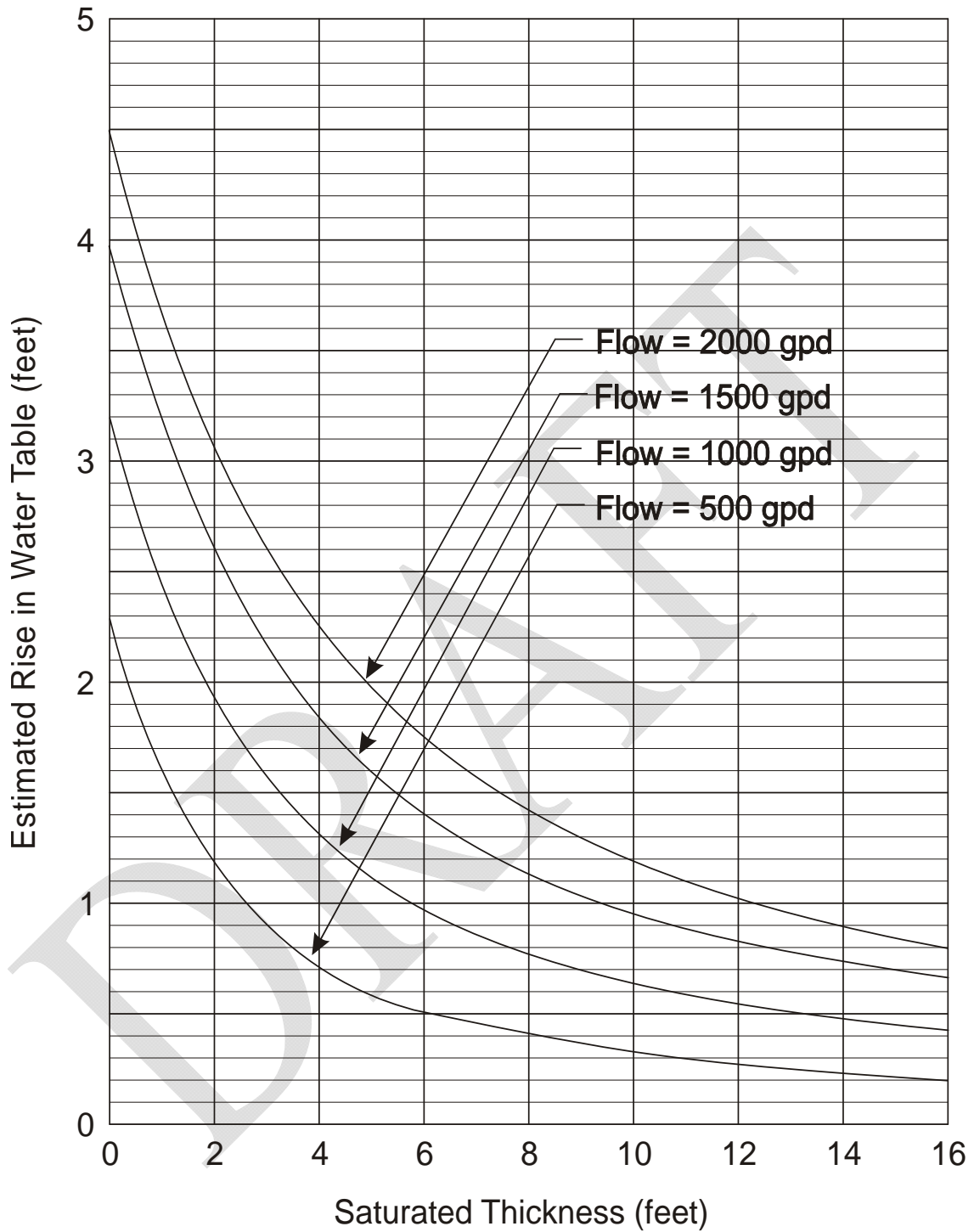

BASED ON A SOIL PERCOLATION RATE = 10 min/inch

FIGURE 1

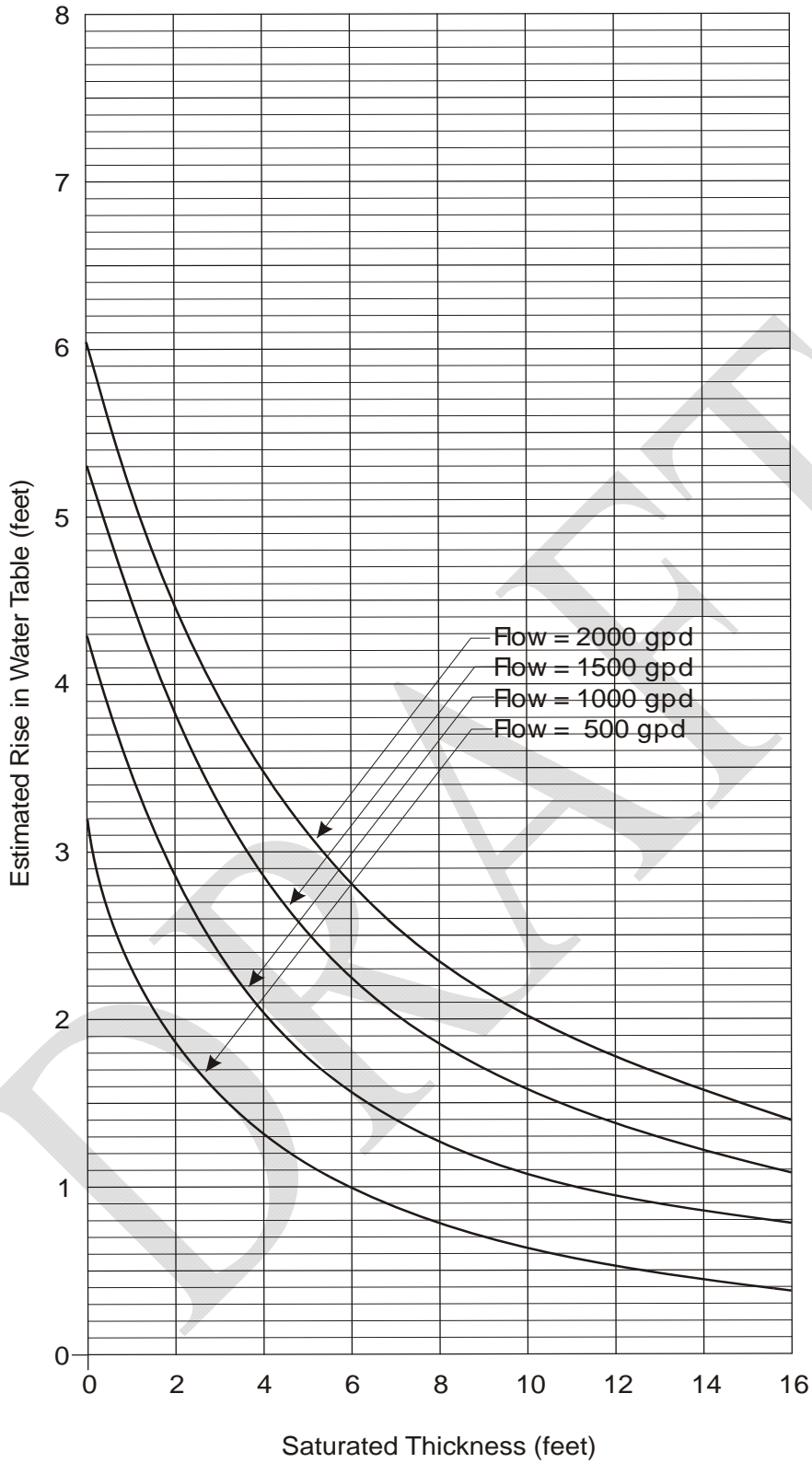

BASED ON A SOIL PERCOLATION RATE = 20 min/inch

FIGURE 2

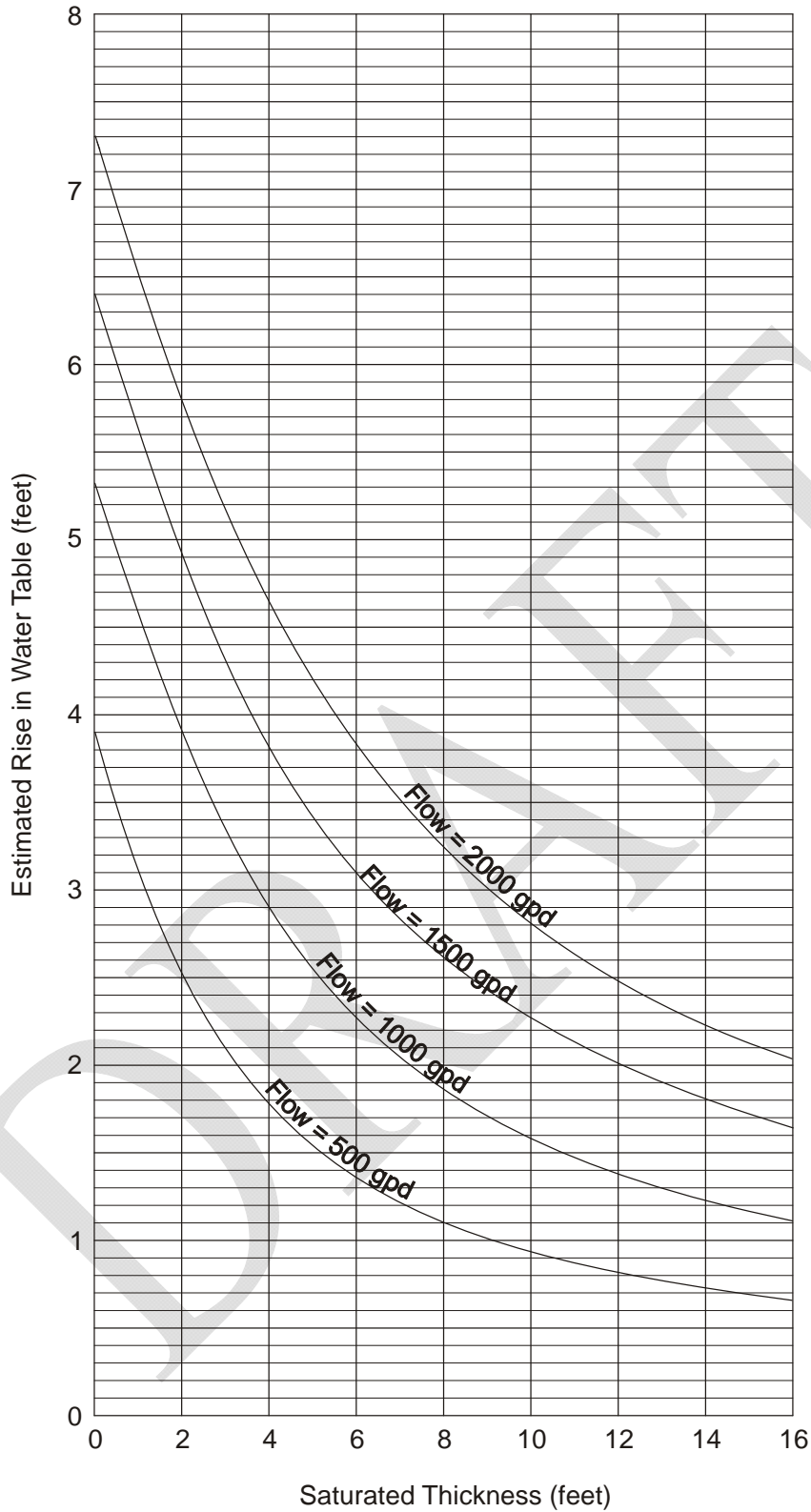

BASED ON A SOIL PERCOLATION RATE = 30 min/inch

FIGURE 3

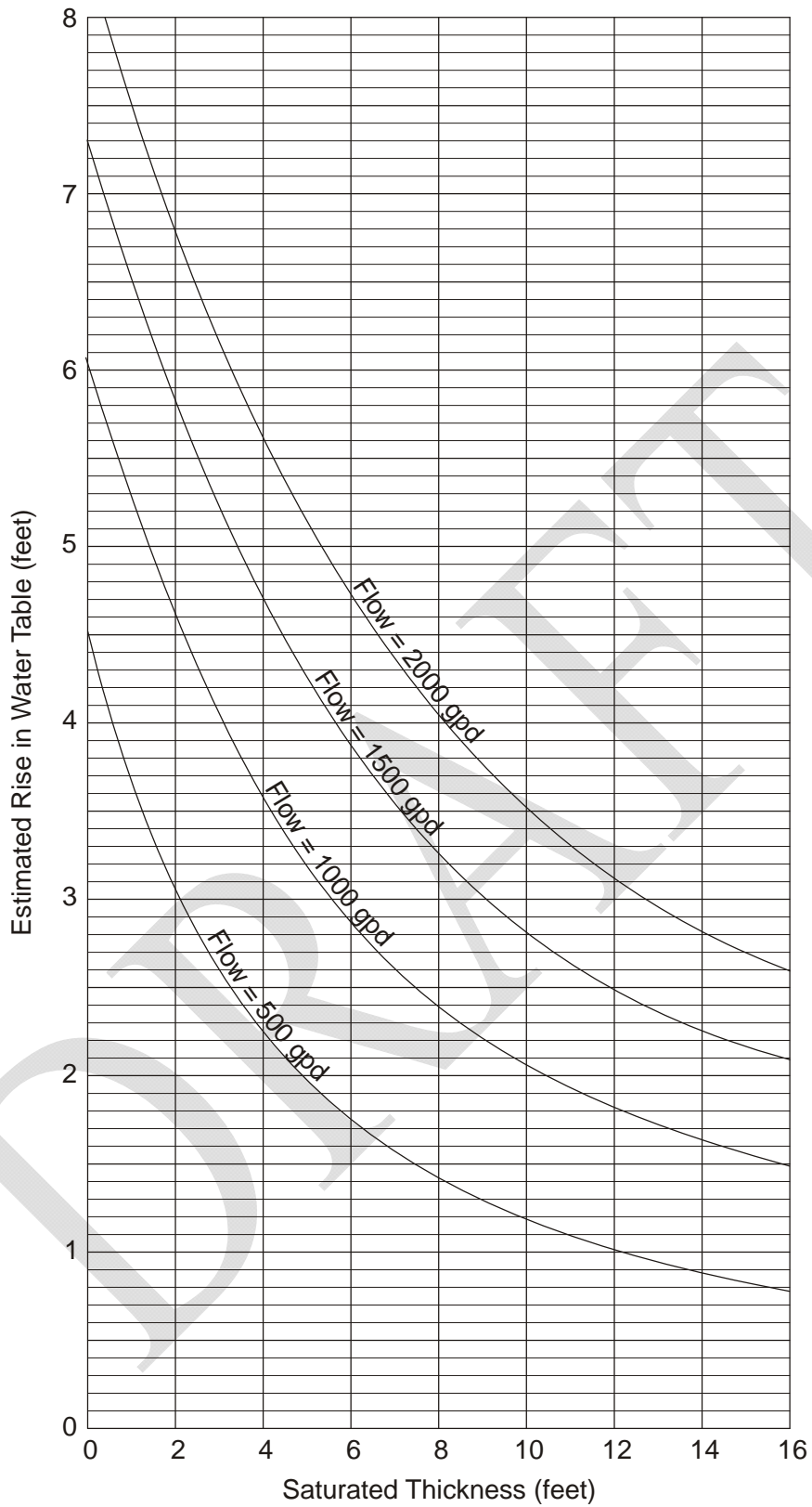

BASED ON A SOIL PERCOLATION RATE = 40 min/inch

FIGURE 4

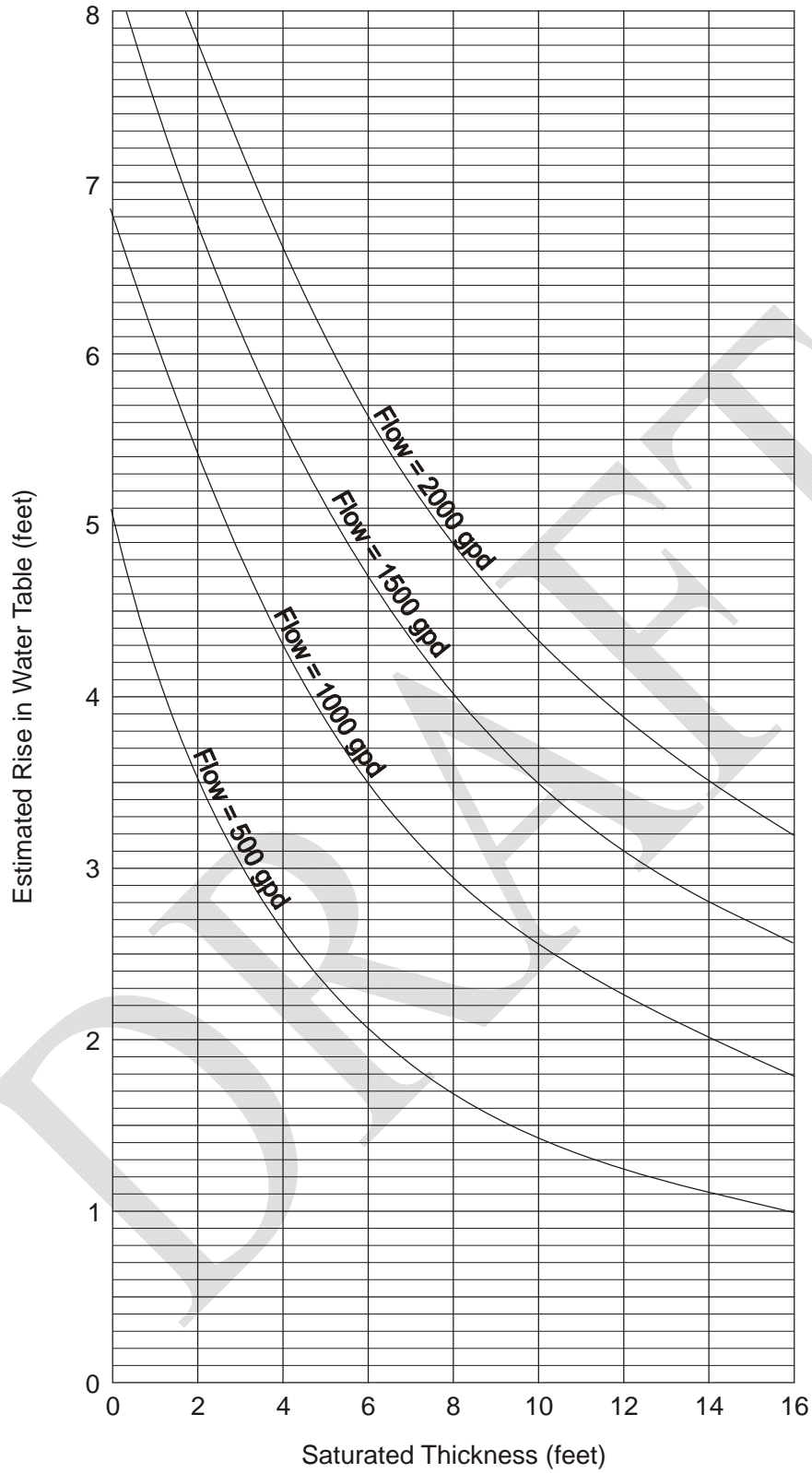

BASED ON A SOIL PERCOLATION RATE = 50 min/inch

FIGURE 5

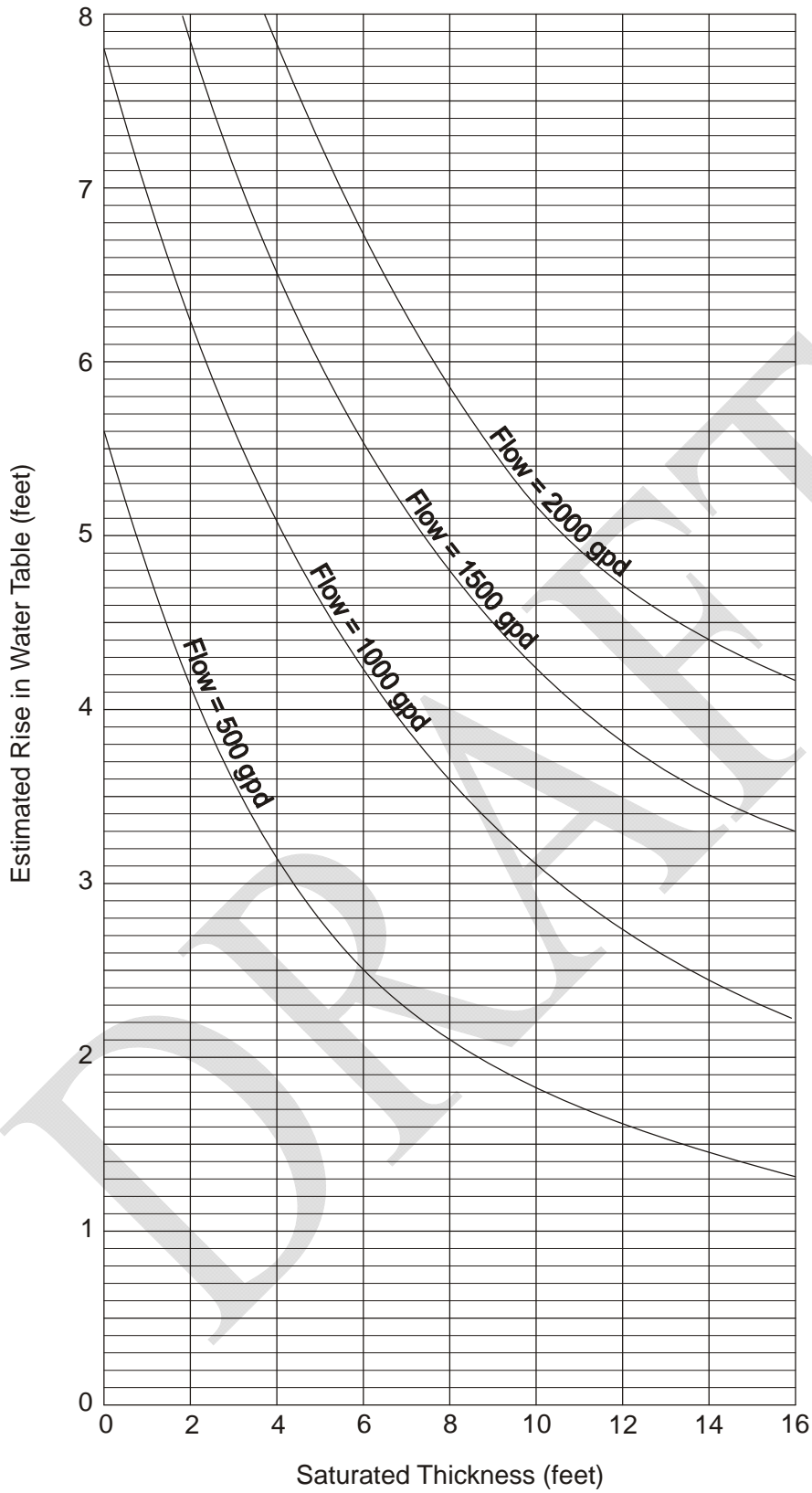

BASED ON A SOIL PERCOLATION RATE = 60 min/inch

FIGURE 6

~~(formerly Section 5(e))(e) Sloping ground installations~~ Slope

~~(formerly Section 5(e)(i))(i) Absorption systems shall not be located in an area where the natural slope is steeper than stated below. The natural slope of the site shall not exceed twenty-five percent 25%, 4-foot horizontal to 1-foot vertical.~~ The following are the maximum permissible slopes on which an absorption system may be constructed.

**Table 3. Slope and Percolation Rates for Absorption Systems**

Percolation Rate (minutes/inch)	Maximum Slope <sup>1</sup>
Faster than 5	25%
6-45	20%
46-60	15%

<sup>\*1</sup> Flatter slopes may be required where the effluent may surface downslope.

(ii) Serial distribution, with the use of drop boxes or approved fittings, is the preferred installation method for sloping terrain. The bottom of individual trenches shall be level and the trenches shall be constructed to follow the contours of the land.

(iii) The placement of multiple trenches, with each subsequent trench down slope of the previous trench shall be avoided when the addition of effluent to the soil absorption system trenches may lead to either an unstable slope or seepage down slope.

~~(formerly 5(e)(ii))(iv)~~ All absorption surfaces must be located at least 15 feet from the top of any break in slope which exceeds the maximum ~~allowed in subsection (i) above~~ slope allowed.

(f) Soil exploration pit and percolation tests

(i) Delegated small wastewater programs shall require a percolation test in addition to the soil exploration pit.

~~(ii) (formerly 5(a))~~ Soil exploration. Soil exploration. A minimum of one soil exploration pit within the proposed soil absorption system location shall be excavated ~~absorption system shall be made to provide information on subsoil conditions.~~ to a minimum depth of four (4) feet below the bottom of the proposed soil absorption system to evaluate the subsurface conditions.

~~(formerly 5(b))~~ Soil evaluation.

~~(formerly 5(b)(i))~~ No less than three percolation tests shall be run in the proposed absorption system location. The percolation tests shall be performed in accordance with Appendix A of this part. The type of soil encountered at the percolation test location shall be specified.

~~((formerly 5b)(ii))~~ (iii) An evaluation of the soil texture, in the proposed soil absorption system location, by a person experienced in soils classification, may be used to confirm the percolation rate. ~~but at least one percolation test shall be performed. The percolation test shall be performed in accordance with Appendix A of this chapter.~~



~~(formerly Section 4)(g)~~ Isolation Minimum horizontal setback distances (in feet) are as follows:

~~(formerly 4(a))~~— Domestic wastewater. The isolation distances listed below apply when domestic wastewater is the only wastewater present.

~~(formerly 4(a)(i))~~— If the flow is less than 2000 gallons per day (gpd), the minimum isolation distance (in feet) shown in Table 2 shall be maintained.

~~(formerly Table 2)~~ Table 4. Minimum Horizontal Setbacks<sup>1,2</sup>

From	To Septic Tank Or Equivalent	To Absorption System
Wells (includes neighboring wells)	50	100
<u>Public Water Well</u>	<u>50/300<sup>2</sup></u>	<u>200/600<sup>2</sup></u>
Property lines	10	10
Foundation Wall (w/o drains)	5	10
Foundation Wall (with drains)	5	25
Potable Water Pipes	25	25
Septic tank	<u>N/A</u>	10
<del>Stream or</del> Surface <del>Body of</del> Water, <u>Spring</u> (including seasonal and intermittent)	50	50
<u>Cisterns</u>	<u>25</u>	<u>25</u>

<sup>1</sup> ~~(formerly 4(b))~~ For disposal of ~~wastewaters other than domestic~~ non-domestic wastewater, the isolation distance shall be determined by a hydrogeological study in accordance with Section ~~15~~ 17(b) of Chapter 3, but shall not be less than the distances shown in Table 4.

<sup>2</sup> The larger horizontal setback shall apply when the soil absorption system discharges to the same aquifer that the public water well draws from. A hydrogeological study in accordance with Section 15(b) of Chapter 3 shall be performed to determine if the setback distance can be reduced.

~~(formerly 4(a)(ii))~~— If the flow is greater than 2000 gpd but less than 10,000 gpd, the minimum isolation distances (in feet) shown in Table 3 shall be maintained.

~~(Formerly) Table 3~~

<u>From</u>	<u>To Septic Tank Or Equivalent</u>	<u>To Absorption System</u>
<del>Wells (includes neighboring wells)</del>	<del>50</del>	<del>200</del>
<del>Property lines</del>	<del>10</del>	<del>10</del>
<del>Building Foundation (without foundation drains)</del>	<del>5</del>	<del>10</del>
<del>Building Foundation (with foundation drains)</del>	<del>5</del>	<del>50</del>

Potable Water Pipes	25	50
Septic tank		10
Stream or Surface Body of Water (including seasonal and intermittent)	50	100

(iii) For systems larger than 10,000 gallons per day, the isolation distance shall be determined by a hydrogeological study in accordance with Section 15(b) of Chapter III, but shall not be less than those in subsection two above.

**Section 7. Soil Absorption System Sizing.**

~~(formerly 7(a)) Trench, bed and seepage pit systems.~~ The total infiltrative surface of a soil absorption system area of a soil absorption system shall be calculated ~~based on the flow rate as determined by the criteria stated in Section 3 and with the allowable loading rate as determined by using Figure 7.~~ by dividing the design flow rates (gpd) from Table 1 or Table 2 by the loading rate (gpd/ft<sup>2</sup>) found in Table 5. ~~The total infiltrative surface is the sum of the sidewall and bottom areas of the absorption system below the invert of the distribution pipe.~~

(b) ~~Soils with a percolation rate of 60 minutes per inch or greater are unacceptable for standard absorption systems.~~ The total infiltrative area shall be defined as follows:

(i) For standard trenches, perforated pipe embedded in aggregate, the total infiltrative area shall be calculated by multiplying the total length of the trench (ft) by the sum of the bottom width (ft) and the height (ft) of each sidewall. The sidewall height is the depth below the flowline of the pipe to the bottom of the trench. The maximum credit for sidewall height shall not exceed twelve (12) inches even if the actual sidewall height exceeds twelve (12) inches.

(ii) For chamber trenches, the total infiltrative area shall be calculated by multiplying the total length of the trench (ft) by the sum of the bottom width (ft) of the chamber and the height (ft) of each sidewall. The sidewall height is the height of the slotted sidewall of the chamber. The maximum credit for sidewall height shall not exceed twelve (12) inches even if the actual sidewall height exceeds twelve (12) inches.

(iii) For bed systems, the total infiltrative area shall be calculated by multiplying the total length (ft) by the width (ft) of the bed. The sidewall credit shall not be used in calculating the total infiltrative area for a bed system.

~~(formerly 5(d))(c) Excessively permeable soils.~~ Coarse sand or soils having a percolation rate ~~of less than one (1) minute per inch or less~~ are unsuitable for subsurface ~~effluent sewage~~ disposal. These soils may be used if ~~a six inch a one (1) foot layer of soil fine sand or loamy sand having a percolation rate of five minutes per inch or greater~~ is placed ~~between the leach system stone and the existing soil~~ below the constructed soil absorption system. The soil absorption system shall be sized based on the percolation rate of the fill material

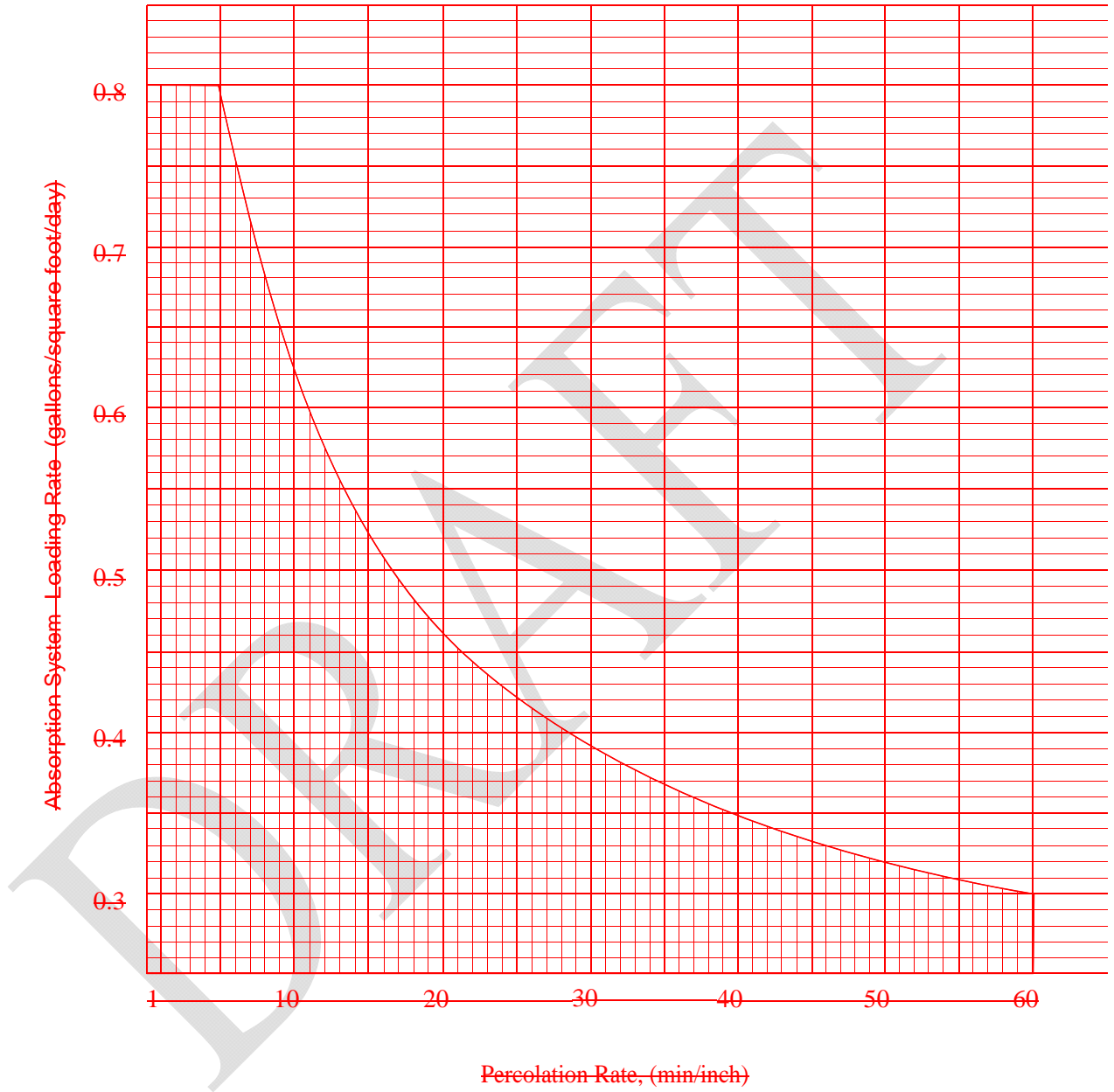

FIGURE 7

**Table 5. Rates of Wastewater Application for Soil Absorption System Areas**

<u>Percolation Rate (mpi)</u>	<u>Loading Rate (gpd/ft<sup>2</sup>)</u>	<u>Percolation Rate (mpi)</u>	<u>Loading Rate (gpd/ft<sup>2</sup>)</u>
<u>1-5</u>	<u>0.80</u>	<u>33</u>	<u>0.38</u>
<u>6</u>	<u>0.75</u>	<u>34</u>	<u>0.37</u>
<u>7</u>	<u>0.71</u>	<u>35</u>	<u>0.37</u>
<u>8</u>	<u>0.68</u>	<u>36</u>	<u>0.36</u>
<u>9</u>	<u>0.65</u>	<u>37</u>	<u>0.36</u>
<u>10</u>	<u>0.62</u>	<u>38</u>	<u>0.35</u>
<u>11</u>	<u>0.60</u>	<u>39</u>	<u>0.35</u>
<u>12</u>	<u>0.58</u>	<u>40</u>	<u>0.35</u>
<u>13</u>	<u>0.56</u>	<u>41</u>	<u>0.34</u>
<u>14</u>	<u>0.54</u>	<u>42</u>	<u>0.34</u>
<u>15</u>	<u>0.52</u>	<u>43</u>	<u>0.34</u>
<u>16</u>	<u>0.50</u>	<u>44</u>	<u>0.33</u>
<u>17</u>	<u>0.49</u>	<u>45</u>	<u>0.33</u>
<u>18</u>	<u>0.48</u>	<u>46</u>	<u>0.33</u>
<u>19</u>	<u>0.47</u>	<u>47</u>	<u>0.32</u>
<u>20</u>	<u>0.46</u>	<u>48</u>	<u>0.32</u>
<u>21</u>	<u>0.45</u>	<u>49</u>	<u>0.32</u>
<u>22</u>	<u>0.44</u>	<u>50</u>	<u>0.32</u>
<u>23</u>	<u>0.43</u>	<u>51</u>	<u>0.31</u>
<u>24</u>	<u>0.43</u>	<u>52</u>	<u>0.31</u>
<u>25</u>	<u>0.42</u>	<u>53</u>	<u>0.31</u>
<u>26</u>	<u>0.41</u>	<u>54</u>	<u>0.31</u>
<u>27</u>	<u>0.41</u>	<u>55</u>	<u>0.31</u>
<u>28</u>	<u>0.40</u>	<u>56</u>	<u>0.30</u>
<u>29</u>	<u>0.40</u>	<u>57</u>	<u>0.30</u>
<u>30</u>	<u>0.39</u>	<u>58</u>	<u>0.30</u>
<u>31</u>	<u>0.39</u>	<u>59</u>	<u>0.30</u>
<u>32</u>	<u>0.38</u>	<u>60</u>	<u>0.30</u>

**Section 8. ~~(formerly Pretreatment)~~ Building Sewer Pipes.**

~~(formerly 6(a))~~ — ~~Building drain pipe. All building drain pipe shall comply with the standards published in the Uniform Plumbing Code 1982 or other locally approved, nationally recognized plumbing code.~~

~~(formerly 6(b))~~ All building sewers shall be installed in accordance with the ~~Uniform Plumbing Code 1982 or other locally approved, nationally recognized plumbing code~~ 2012 International Plumbing Code (IPC). In the absence of an approved plumbing code, and in addition to the IPC, the building sewer shall comply with the following:

~~(formerly 6(b)(i))~~ (a) ~~(Material) Suitable building sewer pipe materials are~~ Polyvinyl Chloride (PVC) and Acrylonitrile-Butadiene-Styrene (ABS) ~~east or ductile iron, portland cement, or vitrified clay pipe shall be used for sewer pipes.~~ The septic tank inlet and outlet pipes shall be ~~east or ductile iron or~~ schedule 40

PVC or ABS pipe and shall ~~extend past the septic tank excavation to solid ground~~ span the excavations for the septic tank and/or dosing chamber. American Society for Testing and Materials (ASTM) D-3034 Standard Dimension Ratio (SDR) 35 plastic pipe may be used if the void at the tank's side is filled with material which is granular, clean and compacted.

~~(formerly 6(b)(ii))~~ (b) **Size.** Building sewer pipes shall not be smaller than four (4) inches in diameter. ~~They shall be~~ and sized to handle the peak hourly flow from the building. When two different sizes or types of sewer pipes are to be connected, a proper type of fitting or conversion adapter shall be used.

(c) Sewer pipe shall not decrease in size flowing downstream.

~~(formerly 6(b)(iii))~~(d) **Slope.** Building sewer pipes ~~shall should~~ be laid at a ~~minimum~~ standard slope of 1/4 inch per foot, but shall not be flatter than 1/8 inch per foot.

~~(formerly 6(b)(iv))~~ **Alignment.** ~~Building sewer pipes should be laid in a straight line. Any single change or cumulative change of alignment of 22 1/2 degrees or greater shall be served by a cleanout.~~

~~(formerly 6(b)(v))~~(e) **Cleanouts.** Cleanouts shall be provided at branch connections, every change in alignment, and at least every 100 feet in straight runs ~~maximum~~.

~~(formerly 6(b)(vi))~~(f) **Backfilling.** All sewer piping shall be laid on a firm bed throughout its entire length. It shall be protected from damage due to rocks, hard lumps of soil, debris and the like.

~~(formerly 6(b)(vi))~~(g) Special care shall be utilized to prevent lateral movement or ~~ovalation~~ deformation during backfill. The backfill material shall be compacted to a density at least equivalent to the trench walls. Backfill over the pipe shall be of sufficient depth to protect the pipe from expected traffic loads and the wastewater from freezing.

### **Section 9. ~~Dosing Systems Following Septic Tanks~~ Septic Tanks and Other Treatment Tanks.**

~~(formerly 8(a))~~(a) Septic tanks:

~~(formerly 8(a)(i))~~ (i) **Material.** ~~The~~ Septic tanks shall be fabricated or constructed of durable concrete, fiberglass or an approved material ~~not subject to excessive corrosion or decay and structurally capable of supporting the loads to which it will be subjected. The tank shall be water tight. The~~ Tanks shall be water tight and fabricated to constitute an individual structure, and shall be designed and constructed to withstand anticipated loads. The design of prefabricated septic tanks shall be reviewed for compliance with applicable construction standards prior to approval for installation.

~~(formerly 8(a)(v))~~ (ii) **Installation.** The septic tank shall be placed on a level grade and a firm bedding to prevent settling. Where rock or other undesirable protruding obstructions are encountered, the opening for the septic tank shall be over excavated, as needed, and backfilled with sand, crushed stone, or gravel to the proper grade.

(A) Septic tanks shall not be buried deeper than the tank manufacturer's maximum designed depth for the tank. The minimum depth of soil cover over the top of the tank is six (6) inches.

(B) Backfill around and over the septic tank shall be placed in such a manner as to prevent undue strain or damage to the tank or connected pipes.

(C) Septic tanks shall not be placed in areas subject to vehicular traffic unless engineered for the anticipated load.

~~(formerly 8(a)(ii))~~(iii) Size-

~~(formerly 8(a)(ii)(A)(A) Residential units serving no more than 4 families. The~~ minimum liquid volume of ~~a~~ septic tanks shall be 1000 gallons for residences ~~through four bedroom capacity up to a six (6) bedroom capacity.~~ Additional capacity of ~~250~~150 gallons per bedroom shall be provided for each bedroom over ~~four~~ six (6).

~~(formerly 8(a)(ii)(B)(B) Commercial/industrial units.~~ Septic tanks for high strength wastewater or non-residential units shall have a minimum effective liquid capacity sufficient to provide at least ~~36~~48 hour retention at peak flow or 1,000 gallons, whichever is greater.

~~(formerly 8(a)(iii))~~(iv) Configuration

~~(formerly 8(a)(iii)(A)(A) The Single compartment septic tanks~~ shall have a length to width ratio of no less than ~~two (2) to one (1),~~ or be so partitioned as to ~~provide protection~~ protect against short circuiting of flow. ~~The water depth shall be no less than four feet nor greater than six feet. The inlet pipe shall be at least three inches higher than the outlet pipe.~~ 

~~(formerly 8(a)(iii)(B)(B) If the septic tank is partitioned, For septic tanks with two (2) compartments or more the volume of the first compartment must be at least 50 percent of the total required volume, the inlet compartment shall not be less than one-half (1/2) of the total capacity of the tank. The partition shall allow venting of the tank. The liquid depth shall not be less than three (3) feet nor greater than six (6) feet.~~

~~(formerly 8(a)(iii)(C)(C) The outlet elevation shall be designed to provide a distance of 20 percent of the liquid depth between the top of the liquid and the bottom of the septic tank cover for scum storage. The tank partition shall allow the venting of gases between compartments and out through the vent stack on the plumbing system of the house. Gases generated during liquefaction of the solids are normally vented through the building's plumbing stack vent.~~

~~(formerly 8(a)(iii)(A)(D) The septic tank inlet and outlet on all tanks or tank compartments~~ shall be provided with a open-ended sanitary tees or baffles. ~~The outlet shall be provided with a tee or baffle that extends into the middle third of the water depth to prevent floating or settled solids from carrying over into the disposal field or bed. The inlet shall be provided with tee or baffle made of approved materials constructed to distribute flow and retain scum in the tank or compartments.~~

(I) The tees or baffles shall extend a minimum of six (6) inches above and nine (9) inches below the liquid level, but shall not exceed one-third (1/3) the liquid depth.

(II) A minimum of three (3) inches of clear space shall be provided over the top of the baffles or tees.

~~(formerly 8(a)(iii)(A))~~ (III) The inlet pipe shall be at least ~~three~~ two (2) inches higher than the outlet pipe. ~~(formerly 8(a)(iii)(C))~~ The outlet elevation shall be designed to provide a minimum distance

of nine (9) inches or twenty (20) percent of the liquid depth, whichever is greater, between the top of the liquid and the bottom of the septic tank cover for scum storage and the venting of gases.

(v) If additional septic tank capacity over 1,000 gallons is needed, it may be obtained by joining tanks in series provided the following requirements are met:

(A) The outlet of each successive tank shall be at least two (2) inches lower than the outlet of the preceding tank, and shall be unrestricted except for the inlet to the first tank and the outlet for the last tank.

(B) The first tank or the first compartment of the first tank shall be equal to fifty percent (50%) or larger of the total septic tank system volume.

~~(formerly 8(a)(iv))(vi) — Access. A manway access riser shall be provided to each compartment of the septic tank for inspection and cleaning. A cleanout having a minimum diameter of six inches shall be provided in each tank compartment and shall extend to the ground surface and be capped.~~

~~(formerly 8(a)(iv)) (A) The manway access riser shall have a minimum opening diameter of twenty (20) inches in the least dimension. Both inlet and outlet devices shall be accessible.~~

(B) The riser shall terminate at a maximum of six (6) inches below the ground surface. Riser covers terminating above grade shall have an approved locking device.

(vii) Land application of domestic septage in remote areas that meet the conditions found in Appendix B will be permitted as a permit by rule. Delegated small wastewater programs may issue individual permits.

(viii) An effluent filter with an opening of 1/8-inch or smaller shall be provided on the outlet of a septic tank or other tank that precedes a small diameter pressure distribution system.



~~(formerly 8(b)) — Aerobic units.~~

~~(formerly 8(b)(i)) Residential units serving no more than four dwelling units. Aerobic treatment units can be used as a pretreatment device for a single residential unit serving no more than four families provided the unit carries the seal of testing and approval from the National Sanitation Foundation (NSF) for the NSF Standard No. 40—1978. The unit shall be sized based on the flow quantities stated in Section 3. No reduction in the sizing of soil absorption systems or the final treatment systems shall be permitted if an aerobic unit is used instead of a septic tank.~~

~~(formerly 8(b)(ii)) Commercial and residential units serving more than four families. Aerobic units treating wastewater generated from other than a single residential unit serving four families or less shall meet the design requirements of Part B or Part C of Chapter XI~~

~~(formerly 9(a))(b) Pumping systems for flow up to 2000 gallons per day. Dosing tanks~~

~~(i) Pump tank. Where only one pump is provided, the pump tank shall have the minimum volume as required in Table 4 below. The Dosing tanks shall comply with the meet the same material and installation requirements for as septic tanks. The pump tank shall be vented. The vent shall have a downward turn that terminates at least 12 inches above ground and be provided with~~

~~a screen. The pump tank shall have an access manhole provided with an opening at least 20 inches in least dimension. Dosing tanks shall have a 20-inch diameter access riser and it shall be brought to the ground surface.~~

**Table 4**

Pump Tank  
Volume (gallons) Required Between

AVERAGE FLOWS (gallons per day)	“OFF” & “ON” SWITCH	“ON” & “ALARM” SWITCH	“ALARM” SWITCH & TANK INLET	RECOMMENDED PUMP CAPACITY (gpm)
0-499	100	50	200	10
500-999	200	100	400	20
1000-1499	300	100	600	30
1500-2000	400	100	800	40

**Table 6. Dosing Tank Volume (gallons)**

Average Wastewater Flows (gpd)	0-499	500-999	1000-1499	1500-2000
Between Pump “off” and Tank Inlet	350	700	1000	1300
Between Tank Inlet and Alarm Switch	200	400	600	800
Between Alarm switch and Pump “on”	50	100	100	100
Between Pump “on” and Pump “off”	100	200	300	400
Recommended Pump Capacity (gpm)	10	20	30	40

(ii) — Pumps:

(A) — Sizing. ~~The pump shall have a flow rate of at least ten gallons per minute when installed. The pressure loss (feet of head) of the system can be calculated by adding: the elevation difference between the discharge outlet at the soil absorption system and the low water level in the pump tank; and the friction losses incurred in the pressure transfer pipe and distribution piping. Table 5 may be used to estimate the head loss of the pipe when pumping ten gallons per minute and using plastic pipe.~~

**Table 5**

Diameter (inches)	Head Loss per 100 feet of pipe (in feet)
1	12
1/4	4
1/2	2

(B) — Installation/removal. ~~The pump shall be installed in the tank so that it can be~~



removed without entering the tank. This can be accomplished by (1) looping the pipe up near the access manhole with a pipe union provided at the top of the loop, (2) using a quick disconnect sliding coupler, or (3) using a pitless adapter. Chains, cable, or piping can be used to lift the pump out of the tank if designed for this loading. Setting the pump on an 8-inch block minimizes the transfer of any solids that may enter the pump tank.

(iii) ~~Pressure transfer pipe.~~ The pressure transfer piping between the tank and the leach system shall be designed to drain after each pump cycle to prevent freezing. This can be accomplished by either eliminating the check valve at the pump or by providing a weep hole in the pipe in the tank. If the pipe is long, the tank shall be enlarged by the volume of the pipe to accommodate the volume of liquid drained from the pipe.

(b) ~~Syphons.~~ Where automatic syphons are used, they shall be designed to empty the syphon tank in less than 20 minutes. The syphon tank shall be sized in accordance with Section 9(a)(i) above.

(c) ~~For all systems exceeding 2000 gallons per day.~~ The pumping system shall comply with the standards of Part B of Chapter XI.

~~(formerly 9(a)(ii)(C))~~ (ii) ~~Electrical controls.~~ The electrical control system for the wastewater pump shall consist of a “pump off” switch, a “pump on” switch, and a “high water alarm” switch which shall be located to provide the necessary volumes as stated in Table 4. High water alarms shall be provided for all tanks that utilize pumps or syphons. The alarm device shall be an audible alarm or an indoor illuminated alarm or both. All electrical controls (pump electrical cord, switches, etc.) shall comply with the National Electrical Code—1981, Class 1, Group D, Division 1 locations. All openings around the cables or cords entering the tank shall be sealed.

(iii) The minimum effluent level shall achieve complete submergence of the pump.

(iv) Dosed systems using a siphon shall have a dose counter installed to check for continued function of the siphon.

~~(formerly Section 12)~~ (c) Holding tanks

(i) Holding tanks shall meet the same material requirements as septic tanks. Holding tanks shall have a twenty (20)-inch minimum diameter access riser and it shall be brought to ground surface.

~~(formerly 12(a))~~ (ii) ~~Uses.~~ Holding tanks shall not be used for residential systems when other alternative systems are available, except on a temporary, seasonal or intermittent basis, or when used to correct a failed subsurface disposal system when other alternatives are unavailable. ~~Use of holding tanks for new construction is prohibited.~~

~~(formerly 12(b))~~ ~~Acceptance.~~ A letter of verification from the local receiving agency, denoting acceptance of the wastewater generated shall be submitted with the plans.

(iii) ~~(formerly 12(c))~~ ~~Location.~~ The location and construction of holding tanks shall meet the requirements for septic tanks in Sections 4(a)(i) and Section 8(a)(i) respectively. Holding tanks must be located in an area readily accessible to the pump truck and where the tank itself will not float due to a high groundwater. If seasonal high groundwater may be present, the tank shall be properly anchored.

~~(formerly 12(a)) (iv) Where holding tanks are allowed, they shall be sized on the basis of seven days storage at the flow rate determined from Table 1. The minimum liquid volume shall be the greater of 1,000 gallons or seven (7) days storage based upon flow rate determined from Section 4.~~

~~(formerly 12(d)) Vent. Each holding tank shall be provided with a two inch minimum diameter vent ending in a return elbow above final grade. The vent shall terminate at least 30 feet from any door, window, or fresh air inlet. The vent should be screened.~~

~~(formerly 12(e)) (v) Alarm. All holding tanks shall be equipped with a high water-level alarm. The device shall be an audible alarm or an indoor illuminated alarm or both. The alarm level shall be placed at 3/4 the depth of the tank.~~

~~(formerly 12(f)) Pumpout. A six inch pump out pipe which extends to the surface shall be provided. It shall be capped at all times.~~

~~(formerly 9(e)(d) Grease Interceptors~~

~~(e) Interceptors grease, oil, silt and sand.~~

~~(i) When required. Liquid wastes containing grease, oil, or silt and sand A commercial or institutional food preparation facility with a waste stream containing fat, oil, and grease (FOG) in excess of 25 mg/L shall provide install an exterior grease interceptor or a device approved by the delegated health department or county before the septic tank. Waste streams from residential living units are exempt from this requirement. Facilities that typically have waste streams high in FOG are, but not limited to, restaurants, cafeterias, slaughterhouses, or institutional kitchens.~~

~~(ii) Material. The interceptor shall meet the material requirements of Section 8(a)(i). Waste streams high in FOG shall be plumbed separately and directly to a grease interceptor prior to the waste treatment process.~~

~~(iii) Waste streams from sanitary facilities such as bathrooms, toilets, urinals, or other similar fixtures shall not be discharged into the grease interceptor. These sources must be connected at least 4-6 feet downstream of the grease interceptor's discharge. The design shall prevent any backflow from the sanitary sources into the grease interceptor.~~

~~(iv) Only one source facility per grease interceptor shall be allowed.~~

~~(formerly 8(e)(v)) Access. The access shall meet the requirements of Section 8(a)(iv).~~

~~(formerly 8(e)(vi)) Location. (v) Grease interceptors shall be located so that they are easily accessible for inspection, cleaning, and removal of the collected wastes. Interceptors shall be placed as close as practical to the fixture it serves. The wastewater from fixtures not producing grease, oil, or sand and silt shall bypass the interceptor. The interceptor shall not be closer than fifteen (15) feet from the last discharging fixture and no further away than thirty-five (35) feet.~~

~~(formerly 8(e)(iv))~~ (vi) ~~Configuration. Grease~~ interceptors shall have ~~a minimum~~ of two (2) compartments with ~~the first compartment having at least 50 percent of the total required volume~~ a 20-inch minimum diameter clean out riser for each compartment. ~~Each compartment shall be vented. Each clean out riser shall be brought to the surface and have a sealed lid that is rated for any anticipated load. There shall be a means provided to sample the effluent.~~

(vii) There shall be no internal cleanout tees or bypasses.

(viii) The inlet and outlet of the grease interceptor shall be vented. The vent pipe shall be at least two (2) inches in diameter. The inlet and outlet vents shall not be interconnected.

(ix) The outlet pipe invert shall be no more than two (2) inches lower than the inlet invert.

(x) The dividing wall between compartments shall be the same height as the other walls and the cover must contact the top of the dividing wall.

(xi) The effluent from each compartment shall be drawn from the bottom of a riser pipe that terminates at least eighteen (18) inches below the inlet pipe invert of that same compartment.

(xii) Grease interceptors shall be accessible during normal business hours without interrupting normal business operations.

(xiii) Grease interceptors shall be installed in accordance with the manufacturer's instructions and applicable requirements of this section. A copy of the manufacturer's instructions shall be submitted with every permit to construct application submitted to DEQ.

~~(formerly 8(e)(iii))~~ (xiv) Grease interceptors shall be sized ~~using one of the~~ according to the following ~~formulas~~:

(A) The minimum volume shall not be less than 750 gallons.

(B) Shall be sized according to the following:

~~Commercial kitchens (grease, garbage)~~

Number of meals per peak hour	X	Waste Flow rate*	X	Retention time**	X	Storage factor***	=	Interceptor size(liquid capacity)
-------------------------------	---	------------------	---	------------------	---	-------------------	---	-----------------------------------

~~Car wash (sand, silt, oil)~~

Total washer equipment flow rate (GPM)	X	60	X	Retention time	X	Storage factor	=	Interceptor size (liquid capacity)
--	---	----	---	----------------	---	----------------	---	------------------------------------

**Laundries (grease, lint, silt)**

Number of 2 cycles machines X per hour	X	Waste flow rate	X	Retention time	X	Storage factor	=	Interceptor size (liquid capacity)
--	---	-----------------	---	----------------	---	----------------	---	------------------------------------

\*Waste flow rate—see Table 1.

\*\* Retention Times

Commercial kitchen waste:	
Dishwasher and/or disposal	2.5 hours
Single service kitchen:	
Single serving with disposal	1.5 hours
Car washers	2.0 hours
Laundries	2.0 hours

\*\*\*Storage Factors

Fully equipped commercial kitchen	8 hr. operation: 1 16 hr. operation: 2 24 hr. operation: 3
Single service kitchen	1.5
Carwashers	self-serve: 1.5 employee operated: 2
Laundries	1.5 (allows for rock filter)

**Commercial Kitchens (grease, garbage)**

<u>Number of meals per peak hour</u>	<u>X</u>	<u>Waste Flow rate*</u>	<u>X</u>	<u>Retention time**</u>	<u>X</u>	<u>Storage factor***</u>	<u>=</u>	<u>Interceptor size (liquid capacity)</u>
--------------------------------------	----------	-------------------------	----------	-------------------------	----------	--------------------------	----------	---

\*Waste flow rate – see Table 2.

\*\*Retention times

<u>Kitchen waste:</u>	
<u>Dishwasher and/or disposal</u>	<u>2.5 hours</u>
<u>Single service kitchen:</u>	
<u>Single serving with disposal</u>	<u>1.5 hours</u>

\*\*\*Storage factors

<u>Fully equipped commercial kitchen</u>	<u>8 hr. operation: 1</u> <u>16 hr. operation: 2</u>
--	---

	<u>24 hr. operation: 3</u>
<u>Single service kitchen:</u>	<u>1.5</u>

(e) Other interceptors

(i) Interceptors are required for oil, grease, sand and other substances harmful or hazardous to the building drainage system, or the small wastewater treatment system.

(A) Laundries

(I) Commercial laundries, Laundromats, and dry-cleaners shall be equipped with an interceptor in order to reduce the quantity of lint and silt that enter the collection system.

(II) The system must be of adequate size and design to allow for cool-down of wastewater so that separation can be more readily achieved.

(III) The interceptor must be installed with a wire basket or similar device, removable for cleaning, that prevents passage into the drainage system of solids ½ inch (12.7 mm) or larger in size, string, rags, buttons, or other materials detrimental to the waste treatment system.

(IV) Sizing must be in accordance with the following formula:

**Laundries (grease, lint, silt)**

<u>Total gallons per cycle</u>	<u>X</u>	<u>Cycles per hour</u>	<u>X</u>	<u>Retention time*</u>	<u>X</u>	<u>Storage factor**</u>	<u>≡</u>	<u>Lint interceptor</u>
--------------------------------	----------	------------------------	----------	------------------------	----------	-------------------------	----------	-------------------------

\*Retention times

<u>Institutional laundries</u>	<u>2.5 hours</u>
<u>Standard commercial laundry</u>	<u>2.0 hours</u>
<u>Light commercial laundry</u>	<u>1.5 hours</u>

\*\*Storage factors

<u>8 hours of operation</u>	<u>1.0</u>
<u>12 or more hours of operation</u>	<u>1.5</u>

(B) Car Washes

(I) Where automobiles are washed (including detail shops utilizing hand-wash practices), separators shall have a minimum capacity of 1000 gallons for the first bay, with an additional 500 gallons of capacity for every other bay.

(II) Additionally, wash racks must be constructed to eliminate or minimize the impact of run-off from rain/storm events. Minimum requirements are roofed structures with at least two walls and appropriate grading to prevent stormwater infiltration into the sanitary sewer.

(III) An effluent sampling point is required.

(f) Abandonment of septic and holding tanks

The following is the procedure to abandon septic tanks and holding tanks when the system is upgraded, equipment replacement is necessary, or central sewer lines are made available.

(i) The abandoned tank should be pumped and the septage hauled to a licensed facility approved to receive the waste or pump the septage into the newly constructed septic or holding tank. Discharging to a central sewer requires coordination with, and the approval of, the owner/operator of the sewer system.

(ii) Once the abandoned tank is empty, it should be removed and the excavation backfilled. As an alternative to removing the tank, the access covers can be removed and the tank filled with native soil, pit run, or sand.

(iii) If the abandoned tank is part of a Class V UIC facility, the abandonment must also be in compliance with Chapter 16, Section 12.

#### **Section 10. ~~Subsurface Treatment and Disposal Systems~~ Effluent Distribution Devices.**

Distribution boxes and flow divider tees are suitable for level or nearly level ground and are installed before the soil absorption system with the goal of splitting flows equally between soil absorption system laterals. Drop boxes are suitable for sloping ground and are installed to achieve serial loading.

(a) Distribution boxes

~~(formerly 10(a)((vii)(i) Distribution box. If a~~ The distribution box is used, it shall be installed to provide uniform distribution of the wastewater on a level, stable base to ensure against tilting or settling and shall be placed so that it will not be subject to ~~and to minimize movement from~~ frost heave.

(ii) Boxes shall be watertight and constructed of concrete or other durable material.

(iii) Boxes shall be designed to accommodate the inlet pipe and the necessary distribution lines. The inlet piping to the distribution box shall be at least one (1) inch above the outlet pipes and all pipes shall have a watertight connection to the distribution box.

(iv) The box shall be protected against freezing and made accessible for observation and maintenance. 

(v) Boxes shall have flow equalizers installed on each outflow. 

(b) Flow divider tees may be used in place of distribution boxes. 

(c) Drop boxes are suitable for sloping ground and are installed to achieve serial loading. The drop boxes shall meet the requirements in paragraphs (a)(i through v) of this section.

#### **Section 11. ~~Evapotranspiration Beds~~ Standard Soil Absorption Systems.**

~~(a) Sizing. The area of evapotranspiration beds shall be determined using the following formula:~~

~~$$\text{AREA} = 586 \left[ \frac{Q}{\text{PET} - P} \right]$$~~

where:

~~Area = Area of the evapotranspiration bed at the ground surface in square feet~~

~~Q = Average daily sewage flow, gallons per day, (0.6 times the flow determined from Table 1)~~

~~PET = Potential evapotranspiration rate in inches per year~~

~~P = Annual precipitation rate in inches per year.~~

~~(b) Construction.~~

~~(i) If an impervious barrier is necessary for the protection of groundwater it shall be installed between the evapotranspiration bed and the native soil. It shall be a polyvinyl chloride sheet with a minimum thickness of 20 mils or equivalent. A 3 inch layer of sand shall be placed under and over the liner.~~

~~(ii) The bottom 12 inches of the bed shall be filled with clean stone 1/2 - 2 1/2 inches in~~

~~(iii) Perforated pipe complying with Section 10(a)(v) shall be placed in the stone.~~

~~(iv) Four inches of pea gravel (less than 1/4 inch in diameter) or durable filter cloth shall be placed over the stone.~~

~~(v) A 24 inch uniform sand layer in the size range of D50 (0.10mm) shall be placed on top of the pea gravel or filter cloth.~~

~~(vi) A six inch layer of sandy topsoil shall be placed on top of the evapotranspiration bed.~~

~~(vii) The bed should be vegetated with small shrubs and/or grasses such as fescue, brome, or alfalfa.~~

~~(viii) The evapotranspiration bed shall be placed at a depth sufficient to prevent surcharging of the septic tank.~~

~~(formerly 10(a)-(a) General~~ Design Requirements:

(i) All soil absorption systems shall be designed in such a manner that the effluent is effectively filtered and retained below ground surface. The absorption surface accepts, treats, and disperses wastewater as it percolates through the soil.

~~(formerly 10(a)(ii)(ii) Protection. Effort shall be made to protect the natural absorptive properties of the soil. Soil absorption systems shall not be installed during adverse weather or soil conditions. Rain, severely cold temperatures, or excessively moist soils are considered adverse weather or soil conditions.~~

~~All smeared or compacted surfaces shall be restored to their original infiltrative conditions prior to placement of the stone.~~ Soil absorption systems shall not be excavated when the soil is wet enough to smear or compact easily. Open soil absorption system excavations shall be protected from surface runoff to prevent the entrance of silt and debris. All smeared or compacted surfaces shall be raked to a depth of one (1) inch, and loose material removed before filter or filler material is placed in the soil absorption system excavation.

~~(formerly 10(a)(ii))—Runoff. Surface runoff shall be diverted around or away from all soil absorption systems.~~

(iii) Soil absorption systems shall be designed to approximately follow the ground surface contours so that variation in excavation depths will be minimized. The trenches may be installed at different elevations, but the bottom of each individual trench shall be level throughout its length.

~~(formerly 10(a)(ix)) (iv) Earth cover. A minimum of 12 inches of earth shall be placed over the absorption system stone. The earth shall be permeable soil that will allow aeration of the system and will support the growth of grass. The earth cover shall be graded to insure that water will not pond on the surface. Shallow soil absorption system depths are encouraged to promote treatment and evapotranspiration. The minimum soil cover depth over the soil absorption system is one (1) foot. The maximum depth to the bottom absorption surface of a soil absorption system is five (5) feet. Finished grading shall prevent ponding and promote surface water runoff.~~

(v) Pipes, chambers or other products shall be bedded on firm, stable material. Heavy equipment shall not be driven in or over soil absorption systems during construction or backfilling.

~~(formerly 10(e)) (vi)——Special requirements for serial sidehill trench or bed systems. Standard trenches refer to perforated pipe embedded in aggregate-filled trenches which shall conform to the following:~~

~~(formerly 10(a)(v))(A) Gravity pipe. All plastic gravity absorption system. The perforated pipes shall have a minimum diameter of four 4 inches and shall conform to ASTM standard D2729. Suitable pipe materials include: ASTM D-2729-11 PVC, ASTM D-3034-08 PVC, Schedule 40 PVC ASTM d1784-11, and ASTM F810-07 PE. Piping in all horizontally constructed absorption systems shall be laid with the holes centered around the vertical axis at the bottom of the pipe. All field tile pipe shall be spaced 1/4 inch apart. Piping in horizontally constructed absorption systems shall have a maximum slope of three inches per 100 feet.~~

~~(formerly 10(a)(iv)) (B)——Stone. Soil absorption system stone. The aggregate shall be crushed rock, gravel or other acceptable, durable and inert material which is free of fines, sized and has an effective diameter between 1/2-inch to 2 1/2 inches. At least two inches of stone shall be placed over the distribution pipe, and at least six inches of stone shall be placed under and beside the distribution piping. A minimum of 12 inches of stone shall be placed between a seepage pit wall and structural liner. The stone shall be free from sand, silt, and clay.~~



~~(formerly 10(a)(viii))(C) Stone cover. A suitable cover such as untreated building paper, filter cloth, or straw shall be placed over the stone prior to backfilling the system. Prior to backfilling, the aggregate shall be covered throughout with a woven/non-woven geotextile material or a three (3) inch layer of straw.~~

(D) Aggregate shall extend the full width and length of the soil absorption system to a depth of at least twelve (12) inches with at least six (6) inches of drain gravel under the distribution pipe and at least two (2) inches over the distribution pipe.

(E) Maximum width of trench excavation is three (3) feet.

~~(formerly 10(d))(F) Special requirements for trench systems. A minimum separation spacing of trenches (wall to wall) of is three (3) feet or a horizontal distance equal to 1.25 times the vertical depth of the trenches, whichever is greater, of undisturbed soil shall be maintained between adjacent trench sidewalls. Trench spacing shall be increased to nine (9) feet when the area between each trench is considered as reserve area. For clay loam soils that have percolation rates slower than 60 min/in., the nine (9) foot spacing shall also be required but it is not considered as reserve area.~~

~~(formerly 10(f))(vii) Special requirement for bed systems. The distribution system piping shall be spaced no more than 10 feet apart. Standard beds shall conform to the same pipe and aggregate requirements for trenches as found in subparagraphs (vi)(A through D) of this section. Standard beds shall also conform to the following:~~

~~(formerly 10(a)(x))(A) The soils shall be absent of clay with percolation rates faster than 60 minutes per inch. Levelness. The bottom of soil absorption systems and each segment of a sidehill system the bed shall must be level, therefore the site shall be relatively flat, sloping no more than one (1) foot from the highest to the lowest point in the installation area.~~

(B) Distribution laterals within a bed must be spaced on not greater than six (6) feet centers. Sidewalls shall be more than three (3) feet from a distribution lateral.

(C) Beds must not be wider than twenty-five (25) feet if gravity distribution is used. Multiple beds must be spaced at one-half the bed width.

(D) Rubber tired vehicles must not be driven on the bottom surface of any bed excavation.

(viii) Chambered trenches, when used in lieu of perforated pipe and aggregate, shall be installed in conformance with the manufacturer recommendations. No cracked, weakened, modified, or otherwise damaged chamber units shall be used in any installation.

(A) All chambers shall be an open, arch-shaped structure of durable, non-degradable design, suitable for distribution of effluent without filter material.

(B) All chamber endplates shall be designed so that the bottom elevation of the inlet pipe is at least six (6) inches from the bottom of the chamber.

(C) Inlet and outlet effluent sewer pipes shall enter and exit the chamber endplates. Inspection ports shall be installed at all outlet effluent sewer pipes.

(D) All chambers shall have a splash plate under the inlet pipe or another design feature to avoid unnecessary channeling into the trench bottom.

(E) Maximum width of trench excavation is three (3) feet.

(F) Minimum spacing of trenches (wall to wall) is three (3) feet. Trench spacing shall be increased to nine (9) feet when the area between each trench is considered as reserve area. For clay loam soils that have percolation rates slower than 60 min/in., the nine (9) foot spacing shall also be required but it is not considered as reserve area.

(ix) Chambered beds shall conform to the same requirements for chambered trenches as found in subparagraphs (viii)(A through D) of this section. Aggregate, as specified in subparagraph (vi)(B) of this section, or native soil shall be used to fill the space between the chambers. 

~~(formerly 10(e)(x) Special requirements for serial sidehill trench or bed systems. Serial sidehill trench:~~

~~(formerly 10(e)(i)) (A) — Separation. A minimum of ~~three~~ six (6) feet of undisturbed soil shall be maintained between adjacent trench or bed side walls.~~

~~(formerly 10(e)(ii)) (B) Levelness. The bottom of each serial trench or bed system shall be level.~~

~~(formerly 10(e)(iii)) (C) The overflow pipe between serial soil absorption systems shall be set no higher than the mid-point of the upstream distribution pipe. The overflow pipe shall not be perforated.~~

~~(formerly 10(b) — Special requirements for seepage pits. If a structural lining is needed to support stone in a seepage pit, it shall be constructed of durable material not subject to excessive corrosion or decay and structurally capable of supporting the loads to which it will be subjected. The lining shall be perforated or otherwise designed to allow the passage of wastewater. Seepage pits shall be separated by a minimum distance equal to 3 times their diameter.~~

(b) A design package for a standard soil absorption system is provided online at the Division's website to assist you in submitting a completed application for a properly designed wastewater treatment and disposal system. The worksheet and calculations were prepared by a registered professional engineer

employed by the Wyoming Department of Environmental Quality, Water Quality Division. The general design requirements stated in this section are incorporated into the worksheets such that by completing the forms, the system will comply with those requirements.

**Section 12. ~~Holding Tanks~~ Pressure Distribution Systems.**

(a) General Design Requirements:

(i) The basic elements of a pressure distribution system include a dosing tank, filter, and a means to deliver specified doses to a small diameter pipe network within a soil absorption system. Pressure distribution is required for mound systems or for bed systems with a width greater than twenty-five (25) feet.

(ii) Pumps must be sized to match the distribution system curve or demand. Pumps shall be designed for sewage pumping applications and be accessible from the ground surface.

(iii) The control system for the pump and dosing tank shall, at a minimum, consist of a “pump off” switch, a “pump on” switch, a “high liquid alarm”.

(A) All electrical connections must be made outside of the chamber in either an approved weatherproof box or an explosion-proof junction box.

(B) The wiring from the junction box to the control box must pass through a sealing fitting to prevent corrosive gases from entering the control panel.

(C) All wires must be contained in solid conduit from the dosing chamber to the control box.

(iv) The pressure transport piping between the tank and the soil absorption system shall be designed to drain after each pump cycle to prevent freezing.

(A) The ends of lateral piping shall be constructed with long sweep elbows or an equivalent method to bring the end of the pipe to finished grade. The ends of the pipe shall be provided with threaded plugs, caps, or other devices to allow for access and flushing of the lateral.

(B) All joints in the manifold, lateral piping, and fittings shall be solvent-welded using the appropriate joint compound for the pipe material. Pressure transport piping may be solvent-welded or flexible gasket jointed.

(C) Where automatic siphons or other devices are used, they shall be designed to empty the dosing tank in less than ten (10) minutes.

~~(formerly 10(a)(vii)) Pressure pipe. All pressure distribution piping shall be designed to withstand the anticipated pressures with a safety factor of two, provide uniform application of the wastewater, and have non-clogging orifices.~~

(b) A design package for a pressure distribution system is provided online at the Division’s website to assist you in submitting a completed application for a properly designed wastewater treatment and disposal

system. The worksheet and calculations were prepared by a registered professional engineer employed by the Wyoming Department of Environmental Quality, Water Quality Division. The general design requirements stated in this section are incorporated into the worksheets such that by completing the forms the system will comply with those requirements.

### **Section 13. ~~Privies~~ Sand Mound Systems.**

The sand mound consists of a sand fill, an aggregate bed and a soil cap. Pressure distribution shall be used in conjunction with sand mound systems.

(a) Selection Criteria:

The high groundwater level, bedrock or impervious clay layer is less than four (4) feet below the level of the soil absorption system excavation.

(b) Site Requirements:

(i) A minimum of one (1) foot of vertical separation of the native soil is required between the bottom of the sand fill and the top of the high groundwater level, any restrictive layer, or any highly permeable material.

(ii) The percolation rate of the native soil at the interface of the sand fill shall be greater than five (5) and less than sixty (60) minutes per inch. The percolation shall be measured in the top twelve (12) inches of native soil.

~~(formerly 10(e)) (c) — Special requirements for mounded systems.~~ General Design Requirements:

~~(formerly 10(c)(i)) — Sizing~~ (i) Sand Layer

(A) Filter sand shall conform to ASTM C-33, with less than 2% passing the #200 sieve.

(B) The minimum depth of sand below the aggregate bed surface shall be one (1) foot.

~~(formerly 10(c)(ii))(C) — Grade. The finished grade shall extend at least three feet horizontally beyond the stone and then be sloped to the parent soil at a grade no steeper than four horizontal to one vertical. The sand mound shall have a combination of at least four (4) vertical feet of filter sand and unsaturated native soil above the high groundwater level.~~

(D) The top of the sand layer under the aggregate bed shall be level in all directions.

(E) The sand layer shall fill around the perimeter of and to the top of the aggregate bed.

(F) The slope of all sides shall be three (3) horizontal to one (1) vertical or flatter.

~~(formerly 10(c)(i)(B))(G) The interface-infiltrative area between the fill soil and the native soil which is the bottom of the sand fill shall be sized-calculated-based-on-the-infiltration-rate-of-the native-soil-as-determined-by-Figure-7-of-Section-38-by-dividing-the-design-flowrates (gpd) from Table 1 or Table 2 by the loading rate (gpd/ft<sup>2</sup>) found in Table 5, but shall not be smaller than a system designed to the requirements of subsection (ii) below.~~

(ii) Aggregate Bed

(A) The aggregate shall be crushed rock, gravel or other acceptable, durable and inert material which is free from fines, and has an effective diameter between one-half (1/2) inch and two and one half (2 1/2) inch.

(B) The aggregate bed depth shall not be less than nine (9) inches with a minimum of six (6) inches of clean aggregate placed below the distribution pipe and two (2) inches above the distribution pipe. The aggregate shall be covered with an approved geotextile material after installation and testing of the pressure distribution system.

(C) The design shall be a long, narrow bed design with a maximum width of twenty-five (25) feet.

(D) The infiltrative area, which is the bottom of the aggregate bed, shall be calculated by dividing the design flowrates (gpd) from Table 1 and Table 2 by the loading rate of 0.8 gpd/ft<sup>2</sup>.

(iii) Soil Cover

(A) The soil cap shall be constructed of a sandy loam, loamy sand, or silt loam. The depth of the soil cap shall be at least six (6) inches at the edges to twelve (12) inches at the center. The slope of all sides shall be three (3) horizontal to one (1) vertical or flatter.

~~(formerly 10(c)(iii))(B) — Fill soil. The fill soil that is—A layer of top soil at least six (6) inches thick shall be placed between the native soil and the stone over the entire sand mound area. shall have a minimum percolation rate of five minutes per inch. Topsoil shall be placed over the mound to promote vegetative cover. The sand mound should be planted with vegetation that does not require watering and will not establish deep roots. Native grasses are commonly used.~~

~~(formerly 10(c)(iv)) Preparation. All trees, roots, and other organic matter shall be removed from the area to be occupied by the mound.~~

(d) A design package for a sand mound system is provided online at the Division's website to assist you in submitting a completed application for a properly designed wastewater treatment and disposal system. The worksheet and calculations were prepared by a registered professional engineer employed by the Wyoming Department of Environmental Quality, Water Quality Division. The general design requirements

stated in this section are incorporated into the worksheets such that by completing the forms the system will comply with those requirements.

#### Section 14. ~~Chemical Toilets~~ Small Wastewater Lagoons.

~~(a) — General requirements. Chemical toilets shall only be used in the containment of body wastes. These requirements apply only to the use of chemical toilets for permanent structures.~~

~~— (b) — Greywater. If indoor plumbing is installed, a separate greywater disposal is required and shall meet the requirements of Section 3 through 12. The minimum design flows for greywater shall be obtained from Table 1 with a reduction of 33 percent allowed for the elimination of blackwater wastes.~~

~~— (c) — Disposal. All chemical toilet wastes shall be disposed of at an approved wastewater facility. A letter of verification from the receiving agency, denoting acceptance of the wastewater generated shall be submitted with the plans. These wastes shall not be discharged into a soil absorption system.~~

~~— (d) — Construction. Chemical toilets shall be constructed and installed to resist breakage or damage from routine usage. Outdoor chemical toilets shall be adequately stabilized and secured to prevent overturning. Materials used shall be resistant to the sewage wastes and the chemicals encountered. The holding compartment of the toilet shall be constructed to prevent accessibility to the public and to disease transmitting vectors.~~

~~— (e) — Additives. No chemical or biological additive shall be placed in the toilet that may adversely affect the operation of a sewage treatment facility where the toilet waste will ultimately be disposed or that may adversely impact the quality of the groundwater as specified in Chapter VIII, "Quality Standards for Groundwater of Wyoming."~~

(formerly 15(a))(a) General requirements. Selection Criteria:

(formerly 15(a)(i)) (i) — The use of this section for small nondischarging waste stabilization ponds applies only to those systems defined as small wastewater systems. All other treatment systems shall meet the requirements of Part B or Part C of Chapter XI as applicable. Lagoons shall only be considered in areas of the State where the annual evaporation exceeds the annual precipitation during the active use of the lagoon.

(formerly 15(a)(ii)) (ii) Non-discharging waste stabilization ponds Lagoons shall only be constructed in soils ~~allowed where~~ when the percolation rate exceeds sixty (60) minutes per inch and the soil is at least 1 foot thick on both the sides and bottom of the pond extends vertically down at least two (2) feet from the bottom of the lagoon to the seasonal high groundwater table or bedrock formations. ~~If the 60 minute per inch percolation rate cannot be obtained, a sufficient clay shall be incorporated into the top foot of soil until the 60 minute per inch percolation rate is reached. An impermeable artificial liner of 20 mils in thickness may be substituted.~~

(iii) A lagoon shall not be installed on a property less than three (3) acres in size 

(iv) A lagoon shall not be constructed within the 100 year flood plain.

(b) General Design Requirements:

~~(formerly 15(b)) (i) Isolation. The isolation distances shall meet the requirements for absorption systems as specified in Section 4(a)(i). Beyond the horizontal setback distances requirements specified in Section 6(d) of this rule, the lagoon shall not be placed within one hundred (100) feet of the owner's property line.~~

(ii) The use of a septic tank which meets the specifications in Section 9 of this rule shall be required before the small wastewater lagoon.

(iii) The lagoon shall be located and constructed so it will not receive surface runoff water.

(iv) The slope of the lagoon site shall not exceed five (5) percent.

(v) The lagoon site must be located in an area of maximum exposure to sun and wind.

(vi) The lagoon shall be designed for complete retention.

~~(formerly 15(d)) Sizing. (vii)~~ The area of the lagoon shall be calculated based on the following formula.

$$A = \frac{584 \times Q}{(365 \times S) + (E - P) \times 1.3}$$

A = Area of the lagoon at the 5 foot depth water level in square feet 

Q = Average daily sewage flow, gallons per day. ~~(0.6 times the flow determined from Table 1)~~  
(Multiply values from Table 1 or 2 by 0.6 to get average daily flow.)

E = Average annual lake evaporation rate in inches per year. (Note: lake evaporation is less than pan evaporation; lake evaporation equals pan evaporation times a pan coefficient of about 0.7)

P = Average annual precipitation rate in inches per year.

S = Soil permeability in inches per day "S" cannot be greater than 0.25 inches per day "S" shall equal zero for an artificial liner or for bedrock Seepage rate in decimal form. 

~~(formerly 15(e)(i)(viii))~~ The slopes of the ~~inside~~ dikes shall not be steeper than three-(3) horizontal to one(1) vertical ~~nor flatter than four horizontal to one vertical. The slopes of the outside dikes shall not be steeper than three horizontal to one vertical and shall not allow surface runoff to enter the pond. The minimum width of the top of the dike shall be four (4) feet.~~

~~(formerly 15(e)(iii)) (ix)~~ All fill ~~material~~ shall consist of impervious material that is well compacted and free of rocks, frozen soil, or other large material.

(x) The minimum operating depth shall be two (2) feet. The dikes shall provide a minimum freeboard of two (2) feet. 



~~(formerly 15(e)(ii)) (xi) All organic material and debris shall be removed from the pond site prior to construction. The floor of the lagoon shall be level and maintained free of all vegetation.~~

(xii) The influent line into the lagoon must discharge near the center onto a concrete apron at least two (2) feet square.

(xiii) A cleanout or manhole shall be provided in the influent line near the dike. 

(xiv) The area around the small wastewater lagoon shall be fenced to preclude the entrance of livestock, pets, and humans. The fence shall be equipped with a locking gate. The gate shall have a sign indicating "NO TRESPASSING – WASTEWATER LAGOON".

(c) A design package for a small wastewater lagoon is provided online at the Division's website to assist you in submitting a completed application for a properly designed wastewater treatment and disposal system. The worksheet and calculations were prepared by a registered professional engineer employed by the Wyoming Department of Environmental Quality, Water Quality Division. The general design requirements stated in this section are incorporated into the worksheets such that by completing the forms the system will comply with those requirements.

~~(formerly 15(e)) Groundwater protection and bedrock or impermeable soil separation.~~

~~(formerly 15(e)(i)) For single family homes, the depth to seasonally high groundwater shall be at least four feet from the bottom of pond.~~

~~(formerly 15(e)(ii)) For all "small wastewater systems" other than single family homes, a minimum of three feet of unsaturated soil shall be maintained between the bottom of the pond and the estimated groundwater mound imposed on the seasonally high groundwater table. The height of the groundwater mound can be estimated from Figures 1-6, Section 5 in conjunction with the average daily sewage flow.~~

~~(formerly 15(d)(ii)) A minimum water level of at least two feet shall be maintained in the pond at all times, including start up.~~

~~(formerly 15(d)(iii)) A minimum free board of two feet shall be provided between the lowest embankment berm and the maximum water level. The maximum water level shall not be less than five feet.~~

~~(formerly 15(e)) Construction requirements.~~

~~(formerly 15(e)(iv)) The minimum top width of the dike shall be eight feet.~~

### **Section 15. ~~Small Non-Discharging Waste Stabilization Ponds~~ Privies.**

Pre-fabricated privies and outhouses with sealed, water-tight vaults shall meet the following conditions.

~~(formerly 13(a)) General requirements.~~



~~(formerly 13(a)(ii) If indoor plumbing is installed, the grey water disposal method shall meet the requirements of Section 3 through 12. The minimum design flow for grey water shall be obtained from Table 1 with a reduction of 33 percent allowed for the elimination of black wastes.~~

~~(formerly 13(a)(iii) The privy shall consist of a vault and an outhouse building.~~

~~(formerly 13(b))(a) — Isolation.~~ The isolation requirements for sealed privies shall comply with Section 6(a)(i) for septic tanks.

~~(formerly 13(d)(ii))(b) The depth to seasonally high groundwater from the bottom of a water tight vault shall be sufficient to prevent floatation of the empty vault.~~

~~(formerly 13(c)) Soil exploration. Soil exploration to a minimum depth of 4 feet below the bottom of the proposed vault shall be made to provide information on subsoil condition.~~

(c) The vault must have sufficient capacity for the dwelling served, and must have at least 27 cubic feet or 200 gallons of capacity.

~~(formerly 13(a)(i))(d) All privies shall be designed and constructed to prevent access by flies and rodents. The privy must be easily maintained and insect tight. The door must be self-closing. The privy seat must include a cover. All exterior openings, including vent openings, shall be screened.~~

~~(formerly 13(d)) Groundwater and bedrock separation.~~

~~(formerly 13(d)(i)) The depth to seasonally high groundwater and bedrock or impermeable soil shall be at least four feet from the bottom of an unlined vault.~~

~~(formerly 13(e)) Sizing. Vaults shall have a minimum capacity of 500 gallons per riser and shall be a minimum of 4.5 feet deep.~~

~~(formerly 13(f)) Construction.~~

~~(formerly 13(f)(i)) The vault shall be constructed and installed to resist breakage and damage imposed by frost heave, uplift pressures from a fluctuating water table, loads imposed by the outhouse building and soils, and damage that may be caused by vandalism or rough cleaning procedures. The vault shall be constructed to prevent access by flies.~~

~~(formerly 13(f)(ii)) Materials used for vault construction shall be resistant to alkali attack, hydrogen sulfide gas, and other corrosive elements associated with decomposing waste.~~

~~(formerly 13(f)(iii)) A clean out manhole shall be installed and shall have a minimum opening of 20 inches in the least dimension. The manhole shall be located outside of the outhouse building and be equipped with a tightfitting secure cover.~~

~~(formerly 13(f)(iv))(e) Privies must be adequately vented.~~ The vault shall be ventilated to a point outside and above the outhouse building. The outhouse building shall have a set of vents installed near the floor on two opposite sides of the building and a roof vent that has a rain cap. All vents shall be screened.

~~(formerly 13(g)) Vault additives. No chemical or biological additive shall be placed in the vault that may adversely effect the operation of a sewage treatment facility where the vault waste will ultimately be disposed or that may adversely impact the quality of the groundwater as specified in Chapter VIII, "Quality Standards for Groundwater of Wyoming".~~

~~(f) Privies shall not be constructed within the 100 year flood plain.~~

#### **Section 16. ~~Commercial/Industrial Wastes. Greywater Systems.~~**

~~(formerly 16 (a)) General requirements. Those requirements listed in Section 1 through 12 and 15 that are applicable to the specific commercial/industrial wastewater or combination of commercial/industrial and domestic wastewater shall apply to this section.~~

~~(formerly 16(b)) Hydrogeologic investigation. If the wastewater is classified as, or determined to be hazardous and/or toxic and/or contain petroleum products, the applicant shall demonstrate to the administrator that any discharge or seepage from the wastewater facility will not cause a violation of the surface and/or groundwaters of the state in accordance with Chapter I, "Quality Standards for Wyoming Surface Waters" and Chapter VIII, "Quality Standards for Wyoming Groundwaters." Due to the wide variety of wastes, wastewater and site conditions, the latest available scientific information shall be used to demonstrate that violation will not occur.~~

~~(formerly 16(c)) Impact. If the impact of the hazardous and/or toxic substance and/or petroleum products cannot be determined and mitigated, disposal of the wastewater using a soil absorption system shall be prohibited.~~

~~(formerly 16(d)) Pre treatment. Pre treatment of the wastewater to remove the hazardous and/or toxic substance(s) and/or petroleum products shall be required prior to disposal if deemed necessary to protect the groundwater of the state. It is the intent of this section to encourage and facilitate the productive and safe reuse of greywater from domestic wastewater.~~

#### (a) Applicability

(i) This section applies to any person who utilizes greywater for beneficial irrigation uses.

(ii) This section is not applicable if the intent is to provide blackwater treatment.

(iii) A city, county, or other local government agency may, after a public hearing and enactment of an ordinance or resolution, further restrict or prohibit the use of greywater systems.

#### (b) Procedure for Estimating Greywater Discharge

(i) The greywater discharge for single family and multi-family dwellings shall be calculated by estimates of greywater use based on water use records, or the following procedure:

(A) The number of occupants of each dwelling unit shall be calculated as follows:

First Bedroom = 2 occupants

Second and subsequent bedrooms = 2 occupants

(B) The estimated greywater flows of each occupant shall be calculated as follows:

Showers, bathtubs and wash basins – 25 GPD/occupant

Laundry – 15 GPD/occupant

(ii) The total number of occupants shall be multiplied by the applicable estimated greywater discharge as provided above and the type of fixtures connected to the greywater system.

(c) Greywater Applications.

(i) General

(A) The total irrigation and/or mulch basin area required, which is the sum of all valved zones, must be equal to the maximum absorption capacity divided by the estimated greywater discharge.

(ii) Subsurface Irrigation

(A) Subsurface irrigation with greywater may be used to irrigate land and vegetation.

(I) Direct human consumption food crops shall not be harvested for 30 days after application of greywater.

(B) Subsurface irrigation shall not surcharge to overland flow.

(I) Direct human consumption food crops shall not be harvested for 30 days after application of greywater.

(iii) Surface Irrigation

(A) Greywater used for surface irrigation shall receive a level of disinfection so the maximum fecal coliform levels is 200/100 ml or less.

(B) Surface irrigation with greywater that has been treated by disinfection may be used for irrigation of land and vegetation.

(iv) Set Backs

(A) A 30 foot buffer zone is required between the greywater application site and adjacent property lines and any public right-of-way when using flood irrigation. This buffer zone requirement may be met by the use of drip irrigation systems.

(B) A 30 foot separation distance is required between greywater application sites and all surface waters.

(C) A 100 foot separation distance is required between greywater application sites and all potable water supply wells.

(d) Greywater Components and Configurations

(i) Flow Diversion

(A) All greywater systems shall have a flow diverter which directs greywater to either the blackwater system or the greywater system.

(B) Diverter valves shall not have the potential to allow backflow from the blackwater system into the greywater system.

(C) Pipe elbows with rotatable compression fittings or equivalent components may be used to connect greywater sources with the greywater system or blackwater system if the pipe can only be connected to one system at a time. A capping device such as a rubber slip cap with band clamp shall be used to seal the plumbing of the system that is not in use.

(D) The rubber discharge hose from a laundry washing machine may be moved between a vertical blackwater riser pipe and a vertical greywater riser pipe without the need for a diverter valve.

(ii) Greywater Collection Tank

(A) When the system design includes a tank, specifications for the tank shall be submitted for approval. Such plans shall show all dimensions and other pertinent data.

(B) Shall be constructed of solid, durable materials not subject to excessive corrosion or decay and shall be water-tight.

(C) Shall be structurally designed to withstand all anticipated earth or other loads. Tank covers shall be capable of supporting an earth load of not less than three hundred (300) pounds per square foot when the tank is used for underground installation.

(D) Shall be covered to prevent access by flying insects, rodents, domestic animals and people.

(E) Shall be vented with a suitable screen to keep animals and insects out of the system.

(F) Inside collection tank shall be installed in accordance with the International Building Code for internal plumbing for black water.

(G) Shall not hold greywater for more than 24 hours.

(H) Overflow Requirements:

(I) Each tank shall have an overflow drain. The overflow drain shall have a permanent connection to the building drain or building sewer, upstream of septic tanks, if any. The overflow drain shall not be equipped with a shutoff valve.

(II) The overflow drain shall not be less in diameter than the inlet pipe.

(III) The overflow system must be designed so that the tank overflow will drain by gravity to the existing sewer line or septic tank. The tank shall be protected against sewer line backflow by a check valve.

(I) Filters:

(I) All discharges from the greywater collection tank shall have suitable filters which retain solids in the greywater collection tank and prevent clogging of the irrigation system.

(II) Shall be accessible for cleaning and maintenance.

(III) Shall be selected based upon expected loading, flow, and pressure.

(J) Each tank shall have its rated capacity permanently marked on the unit. In addition, a sign stating "GREYWATER IRRIGATION SYSTEM, CAUTION – UNSAFE WATER" shall be permanently marked on the holding tank.

(iv) Pumps

(A) Shall be accessible for cleaning and maintenance.

(B) Shall be selected based upon expected flow, pressure and anticipated solids handling according to the overall design.

(C) Shall have a check valve on the discharge of the pump.

(D) Pressurized irrigation systems that are connected to the domestic water system shall have an anti-siphon vacuum breaker installed on the connection to the domestic water system.

(v) Piping

(A) Greywater conveyance pipes shall be permanently labeled for Greywater or shall be colored purple. Non-paint marking pens are unacceptable as permanent labeling.

(B) Gravity flow pipes shall be constructed to allow complete draining of the pipe.

(C) Pressurized pipe systems shall be constructed and designed to be drained or the water evacuated by compressed air for winterization.

(vi) Disinfection

(A) All greywater to be used for surface irrigation shall be disinfected.

(B) Disinfection may be accomplished through chemical methods or ultraviolet disinfection systems.

(I) Chemical disinfection

(1.) Chemical disinfection methods include the use of iodine, chlorine, or bromine.

(2.) Chemical disinfection shall provide the proper dosage of disinfection to achieve a fecal coliform level of 200/100 mL or less.

(II) Ultraviolet disinfection systems

1. Ultraviolet (UV) disinfection systems shall be designed and installed according to the manufacturer's recommendations.

2. Greywater disinfected by a UV disinfection system shall have a UV transmittance less than the UV transmittance rated by the manufacturer.

3. The max flow rate of the UV disinfection system shall not be exceeded.

(vii) Irrigation

(A) General

(I) Irrigation fields may have one or more valved zones. Each zone must be of adequate size to receive the greywater anticipated in that zone.

(II) No irrigation or disposal field shall extend within three (3) vertical feet of the highest known seasonal groundwater, or to a depth where greywater contaminates the groundwater or surface water.

(B) Subsurface Irrigation

(I) Mulch Basins

(1.) Shall be sized to provide sufficient depth, length and width to prevent ponding or runoff during the greywater surge of a clothes washer, bathtub or shower. Mulch shall be replenished as required due to decomposition of organic matter. Mulch basins will require periodic maintenance, reshaping or removal of dirt to maintain surge capacity, to accommodate plant growth, and to prevent ponding or runoff.

(2.) Shall not be deeper than the root zone of the plants to be irrigated.

(3.) Free flow outlets

a. Greywater shall be applied at the top of the mulch.

b. Application point(s) shall be protected from access by flying insects, rodents, domestic animals and people. Protections shall be constructed to allow easy access for cleaning and maintenance.

c. Inlet piping to the mulch basin shall be no less than 1 inch higher than the surface to which it is applied to allow for a free fall of water.

(4.) Sub-mulch outlets

a. Greywater shall be applied below the surface of the mulch into one or more distribution chambers constructed of perforated material.

b. Inlet piping to distribution chamber of the mulch basin shall be no less than 2 inches higher than the surface to which it is applied to allow for a free fall of water.

c. Distribution chamber shall be constructed for easy cleaning and maintenance.

(5.) A compost pile shall meet the requirements of a mulch basin.

(II) Drip systems

(1.) Shall be filtered prior to the point of application or shall be designed to prevent frequent clogging.

(2.) Discharge nozzles shall be specifically designed for the application of greywater without clogging.

(3.) Drilled pipe drip system holes shall be no smaller than ¼” in diameter.

(4.) Point of application flow shall be low enough to prevent any surface flow of greywater.

(III) Permeable pipe systems designed for greywater shall be installed according to manufacturer's recommendations.

(C) Surface Irrigation

(I) Flood irrigation

(1.) Shall not cause channeling or erosion of the application site.  
(2.) Shall use a distribution system to evenly distribute flows across the site.

(3.) Shall not pond in excess of ¼ inch in depth.

(4.) Greywater shall not remain on the ground surface for more than 15 minutes after source flow has stopped.

(II) Spray Irrigation

(1.) Spray irrigation of greywater is not permitted.

(g) Greywater Operation and Requirements

(i) Restrictions

(A) The installation of a greywater system shall not reduce or alter the sizing requirements of the onsite wastewater system.

(B) Human, domestic pets, and animal contact with greywater and soil irrigated with greywater shall be minimized.

(C) Greywater shall not leave the property on which it is generated. Ponding or runoff is prohibited.

(D) Water which has been used to wash diapers or similarly soiled or infectious garments shall not enter the greywater system and shall be diverted into the sanitary sewer or septic system.

(E) Water which contains hazardous materials such as paint, solvents, petroleum products, oil, gasoline, antifreeze, solvents, pesticides and herbicides shall not enter the greywater system. Greywater shall not contain hazardous chemicals derived from activities such as cleaning car parts, washing greasy or oily rags, or disposing of wastewater solutions from home photo labs or similar hobbyist or home occupational activities.

(F) Greywater systems shall not be installed in a delineated floodplain.

(G) The volume of greywater shall not exceed an average of 2000 gallons per day.

(H) Greywater shall not come in direct contact with or adversely impact surface or groundwater.

(I) The filter backwash and flush discharge shall be contained and disposed of into the building sewer system or septic tank with a design capacity to accept all the blackwater and greywater. Filter backwash water and flush water shall not be used for any purpose. Sanitary procedures shall be followed when handling filter backwash and flush discharge or greywater.

(ii) Odor Control

(A) Odor control of the greywater system shall meet the requirement of Wyoming DEQ Air Quality Regulations Chapter 2, Section 11.

(iii) Stormwater

(A) The greywater system shall not be located in a drainage way.

(B) The greywater system shall prevent storm runoff from carrying the greywater off the application site.

(iv) Winter Operation



(A) If the greywater system is to be used during the winter, the greywater system shall be designed to prevent freezing.

**Section 17. Operation and Maintenance.**

(a) For any system that disposes of wastewater through land application or subsurface filtration, the owner shall not add any chemical or biochemical additive to the system that would adversely affect the quality of the groundwater as stated in the WDEQ Water Quality Rules & Regulations, Chapter VIII.

(b) Septic tanks shall be pumped as needed to prevent solids carryover into the soil absorption system.

(c) Holding tanks and sealed vaults shall be pumped prior to reaching their maximum capacity. It is preferable that these types of tanks be pumped before the wastewater volume exceeds 75% of the tank's capacity.

(d) Any service provider that pumps septic tanks, holding tanks, or sealed vaults, shall dispose of the wastewater contents at a permitted wastewater treatment facility or in a manner approved by the Division or delegated authority.

(e) Damaged fittings and broken, crushed or plugged piping associated with any small wastewater system shall be replaced in a timely manner.

(f) Composting or non-discharging toilets where permitted shall have their waste disposed of at a permitted wastewater treatment facility or landfill, or in a manner approved by the Division or delegated authority.

APPENDIX A  
Percolation Test Procedure

Section 1. Purpose

(a) Percolation tests are used to determine absorption system site suitability and to size the absorption system.

Section 2. Procedure

~~(formerly (a)) (a) Location. General Requirements: The percolation test holes shall be spaced uniformly over the proposed absorption field site. A minimum of three test holes are required.~~

(i) Percolation tests shall not be conducted in test holes which extend into groundwater, bedrock, or frozen ground.

(ii) The percolation test shall be conducted only after the soil exploration pit has been dug and examined.

(iii) A minimum of three (3) percolation test holes are required.

(iv) The percolation test holes shall be spaced uniformly over the proposed soil absorption system site.

~~(formerly (b)) (b) Preparation. A 4 inch to 12 inch hole shall be dug or bored to the proposed depth of the absorption field. The walls shall be vertical. To expose a natural soil surface, the sides and bottom shall be scraped with a sharp pointed instrument and the loose material shall be removed from the hole. Coarse sand or gravel shall be placed in the bottom of the hole to prevent it from scouring and sealing.~~

(i) A four (4) inch to twelve (12) inch diameter hole shall be dug or bored to the proposed depth of the soil absorption system.

(ii) The walls shall be vertical, with the natural soil surface exposed without smearing.

(iii) ~~To expose a natural soil surface~~ The sides and bottom shall be scarified with a sharp pointed instrument and the loose material shall be removed from the hole.

(iv) Two (2) inches of gravel or coarse sand shall be placed in the bottom of the hole to prevent it from scouring and sealing during water addition.

(c) Presoaking

~~(formerly (c)) (i) — Presoaking.~~ The purpose of presoaking is to have the water conditions in the soil reach a stable condition similar to that which exists during continual wastewater application. The minimum time of presoaking varies with soil conditions but must be sufficiently long so that the water seeps away at a constant rate. The following presoaking

instructions are usually sufficient to obtain a constant rate.

~~(formerly (c)(i)) (A)~~ In sandy soils, place 12 inches of water in the hole. Fill each hole with clear water to a level at least 18 inches above the gravel or coarse sand and allow it to seep away. Fill the hole again with 12 inches of water and if the water seeps away in ten minutes or less, it indicates that the soil is excessively permeable and requirements in Section 5(d) of these regulations shall be followed. If the 18 inches of water seeps away in 18 minutes or less, add 18 inches of water a second time. If the water remains after ten minutes, additional saturation is necessary. Refer to Appendix A(c)(ii) below. If the second filling of 18 inches of water seeps away in 18 minutes or less, this indicates the soil is sandy and is excessively permeable. The soil absorption system shall meet the requirements of Section 7 (c).

~~(formerly (c) (ii)) (B)~~ In other soils, maintain 12 inches of water in the hole for at least four hours. If either the first or second fillings of 18 inches of water does not seep away in 90 minutes, 18 inches of water must be maintained in the hole for at least 4 hours to presoak the test hole. After the four hours of water contact time, allow the soil to swell for wait-12 hours-before starting the percolation rate measurement-as stated in Appendix A (d) below.

~~(formerly (d) (d))~~ Percolation rate measurement ~~—The water level should be adjusted to six inches above the gravel initially and after each time interval measurement when necessary.~~

~~(formerly (i))(i)~~ In other soils, establish a fixed reference point and measure the drop in water level at constant intervals. The water level drop should be measured to the nearest 1/8 of an inch. The test may be terminated when the water drop is consistent for three consecutive measurements. Fill each test hole with 12 inches of water and allow the soil to rehydrate for 15 minutes prior to any measurements

(ii) Establish a fixed reference point to measure the incremental water level drop at constant time intervals. The water level drop should be measured to the nearest 1/8 of an inch and the minimum time interval is ten (10) minutes.

(iii) Refill the test hole to 12 inches above the gravel before starting the measurements. Continue to measure the incremental water level drop at a constant time interval until a consistent incremental water level drop is achieved. A consistent water level drop is achieved when three (3) consecutive water level drops are within 1/8 inches of each other.

(iv) Before the water level drops below 6 inches above the gravel, refill the test hole to 12 inches and continue to measure the incremental water level drop.

~~(formerly d(ii))(v)~~ The percolation rate ~~for each hole~~ is calculated ~~as follows~~ for each hole using the following formula:

$$\begin{array}{l} \text{Time Interval (Minutes)} \\ \text{Final Water Level Drop (inches)} \end{array} = \begin{array}{l} \text{Percolation Rate} \\ \text{(minutes/inch)} \end{array}$$

~~(formerly d(ii))(vi)~~ If only three to five percolation tests are performed, the

design percolation rate for the absorption system is the slowest rate from all the holes tested. If six or more percolation tests are performed, the design percolation rate for the absorption system is the average of all the holes tested as determined by the above formula.

(e) The following information shall be recorded:

(i) Date(s) of test(s);

(ii) Location, diameter, and depth of each test hole;

(iii) Duration of presoak;

(iv) Time of day for beginning and end of each water-level drop interval;

(v) Each water-level drop measurement;

(vi) Calculated percolation rate;

(vii) Name and signature of person performing test;

(viii) Name of owner or project name;

(ix) Certification that the percolation test was done in accordance with Wyoming Water Quality Rules and Regulations Chapter 25 Appendix A.

APPENDIX B  
Land Application of Domestic Septage in Remote Areas

Section 1. Restrictions and Requirements

To qualify for the land application of domestic septage in remote areas, the following conditions must be met.

(a) Location restrictions shall adhere to the following:

(i) Domestic septage generated on a specific property may be land applied on said property, and shall not be transported to another location for land application.

(ii) No land application of domestic septage shall occur within 1,000 feet of all adjacent properties.

(iii) No land application of domestic septage shall occur within 300 feet of a public road, permanent surface water body, or intermittent stream.

(b) Site restrictions shall adhere to the following:

(i) The land application of domestic septage shall only occur on those sites with established vegetation such as rangeland, pasture or hay meadows.

(ii) No more than 5,000 gallons of domestic septage per acre per year shall be land applied.

(iii) No land application of domestic septage shall occur where the site's slope exceeds five percent (5%) or where the depth to groundwater is less than four (4) feet.

(iv) The land application of domestic septage shall not occur between November 1 and May 1, or any other time when frozen or saturated ground conditions exists.

(v) No public access shall be allowed for one (1) year to any site where domestic septage has been applied.

(vi) No grazing animals shall be allowed access for 30 days to any site where domestic septage has been land applied.

(c) Crop restrictions shall adhere to the following:

(i) No root crops shall be harvested for 38 months from soils where domestic septage has been land applied.

(ii) No truck crops (harvested parts touch land surface) shall be harvested for 14 months from soils where domestic septage has been land applied.

(iii) No commodity crops (other food, feed, and fiber crops whose harvested parts do not touch land surface) shall be harvested for 30 days from soils where domestic septage has been land applied.

(iv) No turf shall be harvested for one (1) year from soils where domestic septage has been land applied.

(d) Reporting requirements:

(i) The property owner shall notify the appropriate Department of Environmental Quality, Water Quality Division (DEQ/WQD) District Engineer prior to the land application of domestic septage to confirm the requirements and to arrange a possible DEQ/WQD inspection of the land application.

(ii) All records concerned with each septage application will be maintained for at least five (5) years.

(iii) There is a worksheet online that must be completed, signed and returned to the DEQ/WQD or the appropriate delegated local permitting authority within 15 days of the land application.



"QUALITY PUMPS SINCE 1939"



SECTION: 3.20.145

FM1730

0205

Supersedes

0604

Product information presented here reflects conditions at time of publication. Consult factory regarding discrepancies or inconsistencies.

MAIL TO: P.O. BOX 16347 • Louisville, KY 40256-0347  
 SHIP TO: 3649 Cane Run Road • Louisville, KY 40211-1961  
 (502) 778-2731 • 1 (800) 928-PUMP • FAX (502) 774-3624

visit our web site:  
[www.zoeller.com](http://www.zoeller.com)

# ZOELLER ON-SITE WASTEWATER PRODUCTS

## INTRODUCING THE TRU-FLOW SPLITTER SYSTEM



Patent No. 6,112,766  
 and 6,152,850

4" riser easily attaches to visually inspect and adjust the diverter.

Sturdy polypropylene box to withstand frost heaves, heavy loads, and corrosion.

Bubble level included for quick and easy installation and service.

Can be field adapted from 2 to 5 outlets.

Diverter can accurately split gravity flows down to 1/10 gpm and pumped flows up to 30 gpm such as enhanced flow or flood dose systems.

Lightweight for quick and easy installations.

### ORDER NUMBERS:

P/N 173-0001 - Tru-Flow Splitter System (Standard with 4" Schedule 35 pipe seals)

P/N 173-0005 - 3" pipe seals. (order in addition to 173-0001.)

P/N 173-0006 - 4" Schedule 40 pipe seals. (order in addition to 173-0001.)

P/N 173-0007 - Zoeller 6" diameter x 36" tall riser for splitter system. Used on deep installations to aid in diverter adjustment. Height is field adjustable.

### Splitter System

This innovative Splitter System will evenly split effluent into two to five lines. It is made of two major parts: (1) the diverter basin & cover and (2) the diverter. The patented bubble level design allows for post construction adjustability and maintenance, thereby solving the problems associated with distribution box settlement. The Tru-Flow® unit may settle as much as 15° front-to back (30° total) and/or 12° side-to-side (24° total) and, when adjusted, will evenly split effluent. The Splitter System works with low flows as well as high flows. This unique design has no parts to wear out and utilizes corrosion resistant materials.

# Technical Specifications

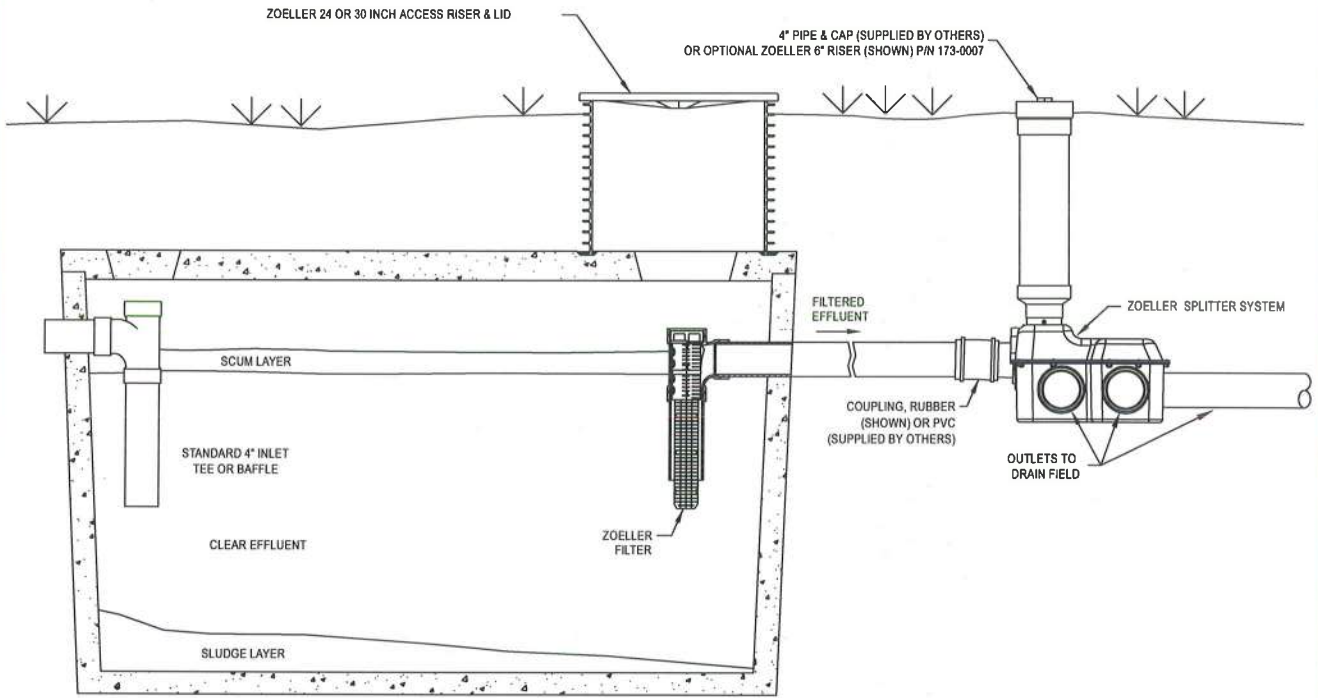

SK1975

**SAMPLE ENGINEERING SPECIFICATION:**

CONTRACTOR must furnish a Zoeller Tru-Flow® splitter system, model 173-0001. A concrete or plastic distribution box requiring speed levelers should not be considered equal. The assembled splitter system must be lightweight to ease the burden of installation. Product must be capable of splitting effluent from 1/10th to 30 gpm evenly into 2 to 5 distribution lines. Product must not require external water for distribution line flow balancing purposes. System must be maintainable from the surface. Bubble level will be built in for easy adjustments and service. A 4" or 6" riser pipe shall be brought to the surface for future access, inspection, and adjustment. Splitter housing shall be rigid enough to withstand the anticipated frost and traffic loading. The splitter system must be made of all non-corrosive materials. Housing shall be made of polypropylene to increase the chemical resistance to the effluent and gases present in the waste stream. Diverter shall be made of virgin ABS to enhance product life. Six 4" SDR 35 pipe seals shall be provided with the unit.

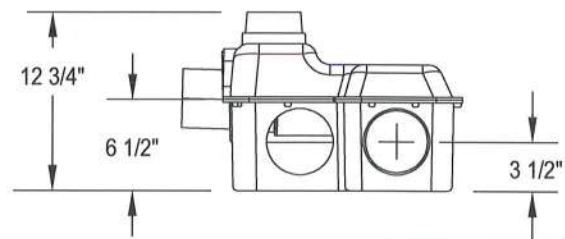
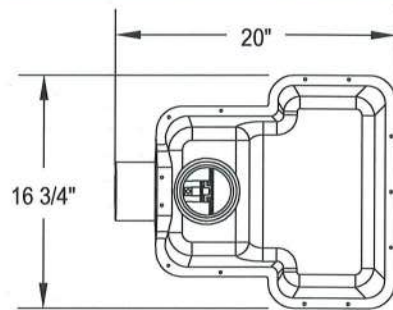

SK1976

**ALL ZOELLER ONSITE PRODUCTS MUST BE INSTALLED IN ACCORDANCE WITH PLUMBING AND HEALTH DEPARTMENT CODES.**

**Distributed By:**



1-800-928-PUMP  
www.zoeller.com





---

**Fwd: Comments -- Title 25**

1 message

---

**William Tillman** <william.tillman@wyo.gov>  
To: Gina Johnson <gina.johnson@wyo.gov>

Mon, May 20, 2013 at 3:11 PM

----- Forwarded message -----

From: **Bo Bowman** <hscplanner@hscounty.com>  
Date: Mon, May 20, 2013 at 2:51 PM  
Subject: Comments -- Title 25  
To: William Tillman <william.tillman@wyo.gov>  
Cc: james.brough@wyo.gov, Hannes Stueckler <hannes.stueckler@wyo.gov>

Bill,

The attached letter contains a few comments addressing your draft Title 25 now being reviewed. Thank you for the opportunity to comment.

*Bo Bowman*

*Bo Bowman*

*Hot Springs County Planner*

*307-864-2961*

--  
William Tillman, P. E.  
Water and Wastewater Section  
Regulatory and Enforcement  
Herschler Building, 4-W  
122 West 25th Street  
Cheyenne, WY 82002  
(307) 777-6941  
(307) 777-6779 (FAX)  
[william.tillman@wyo.gov](mailto:william.tillman@wyo.gov)

"Live like there's no tomorrow. One day you'll be right"

E-Mail to and from me, in connection with the transaction of public business, is subject to the Wyoming Public Records Act and may be disclosed to third parties.

Ch 25 Public Notice Comments for 6-14-13 WWAB Meeting 122  
**Hot Springs County Planning Office**  
**415 Arapahoe, Thermopolis WY 82443**  
**307-864-2961**  
[hscplanner@hscounty.com](mailto:hscplanner@hscounty.com)

Bill Tillman, Regulatory & Enforcement Section Leader  
Wyoming Department of Environmental Quality  
Herschler Building; 122 West 25<sup>th</sup> St.  
Cheyenne, WY 82002

May 20, 2013

Re: Title 25 Review – Comments

Dear Mr. Tillman:

Thank you for the opportunity to comment on the Title 25 revision, and in particular I appreciate your extension of the agency review period through May. Since Hot Springs County's delegated authority is for residential small waste water systems only, I have limited my comments to conventional septic systems and grey water systems. There are several proposed changes from the present-day regulations for which I have no issues. However, I note the following changes that raise questions for me:

1. **Page 25-14.** In Table 5 (application rates), it is noted that percolation rates less than 5 mpi will trigger the requirement for a WY Registered Engineer to determine the loading for the system. At present, the loading rate of 0.80 is applied to percolation rates *up to* 5 mpi. I consider the proposed language to be an improvement, but it does increase the likelihood of a landowner "cooking the books" on his perc test in order to avoid the cost of an engineer. I concede that possibility already exists under the present regulations, but *this redraft of the regulations presents an opportunity for these regulations to deal more clearly with enforcement protocols.* Landowner-generated perc tests are the weakest link in our residential small wastewater system permit process. *While I do not disagree with the notion of requiring engineered design for percolation rates of 1 to 5 mpi, I must play devil's advocate and ask if the requirement is truly warranted.*
2. **Page 25-15.** In Section 9, (a)(ii)(A) states that the minimum cover over a septic tank shall be six inches, not the 12 inches currently required. My concern is that such a minimum depth could lead to increased risk of damaging the tank, and that a 12 inch minimum is more desirable.
3. **Page 25-23.** There is an incomplete sentence in (viii) on the lower half of this page.

4. **Page 25-24.** There is a typo in paragraph (b) in the middle of this page.
5. **Page 25-30.** In (b)(i)(A), the word should read “irrigate” not “irrigation.”
6. **Page 25-30.** In (b)(iii)(D), addressing the use of drip irrigation in buffer zones, I think I understand and agree with the intent. However, it is not described as clearly as it should be.
7. **Page 25-31.** In (A) at the top of the page, describing flow diverters for grey water systems, I understand the intent however the language should state that intent more clearly.

Thank you again for the opportunity to comment. Should you have any questions concerning these comments, please contact me at 307-864-2961 or by e-mail at [hscplanner@hscounty.com](mailto:hscplanner@hscounty.com).

Regards,

*Bo Bowman*

Bo Bowman  
Hot Springs County Planner

**LOUIS B. HARMON PE-LS-PG**

404 WEST PERSHING BOULEVARD  
CHEYENNE WY 82001-2541  
HOME (307) 635-7518  
lharmon@wyoming.com

**RECEIVED**  
MAY 23 2013  
WATER QUALITY DIVISION  
WYOMING

23 May 2013

Wyoming Water and Waste Advisory Board  
% Mr. William Tillman  
DEQ/WQD, Herschler Building 4 West  
122 W 25<sup>th</sup> Street  
Cheyenne WY 82002

RE: Comments on Proposed Revisions the Water Quality Rules and Regulations, Chapter 25

Dear Ladies and Gentlemen:

I thank you for this opportunity to make comments on the proposed revisions the Water Quality Rules and Regulations, Chapter 25. I find the proposed regulations unnecessarily complex and in some instances, too restrictive. Chapter 25, Small Wastewater Systems, is unique among Water Quality regulations in that it is read and used by an individual home or property owner as opposed to professional staff employed by the regulated community. Consequently Chapter 25 needs to be written clearly with a minimum of technical jargon. My comments on certain sections of Chapter 25 follow in order of my perceived importance of the topic, not necessarily in the order that the sections appear in the draft Chapter 25.

When Chapter 25, formerly Part D of Chapter 11, was removed from Chapter 11, the necessary language actually requiring a permit and an application for a permit to construct was left behind. Chapter 25 as presently written does not require either a permit or an application for a permit for the standard systems. A sentence needs to be added to the first paragraph of Section 2 that requires a permit and an application for the permit.

W.S. § 33-29-139 requires that "All maps, plats, plans or designs filed with -- any other office of public record shall be made and certified by a professional engineer -- registered under this act." Any other office of public record includes the DEQ/WQD and any delegated small wastewater program. Immediately after DEQ/WQD R&R Chapter 11 was adopted in 1984, it was recognized that requiring every small wastewater system to be designed and certified by a registered professional engineer placed an unnecessary financial burden on the individual home owner. A compromise was worked out between the Wyoming State Board of Registration for PE's and PLS's that allowed the application package for an individual small waste water system to be prepared as a "cookbook design" and certified by a registered professional engineer employed by the WQD. The State Board of Registration agreed that this approach satisfied the requirements of W.S. § 33-29-139. This agreement is reflected in Section 11 (b) for a standard soil absorption system that states "worksheet and calculations were prepared by a registered professional engineer employed by the Wyoming Department of Environmental Quality, Water Quality Division" and is subsequent sections for other common small wastewater systems. This agreement is periodically challenged by an attorney or engineer not familiar with the history. Chapter 25 should explicitly describe the agreement and why Chapter 25 fulfills the requirements of W.S. § 33-29-139.

The term "permit by rule" appears in Section 9(a)(vii). Permit by rule is not defined.

Section 15, Privies; and Section 16, Greywater Systems should both be identified as allowed by "permit by rule" with no correspondence required with DEQ or the delegated authority required unless specific rules are developed by the delegated authority requiring permitting. If the intention is that only water tight vaults are allowed for privies that should be stated. The present draft could be interpreted that a pit privy with an unlined vault is completely unregulated.

Section 16, Greywater Systems, is far too restrictive. It should be shortened to three sentences. "Greywater systems are permitted by rule. Greywater systems must not allow a discharge off of the residential property where the wastewater system is generated. Greywater reuse from other than residential wastewater sources shall be treated as land application of wastewater subject to the requirements of Chapter 21, DEQ/WQD R&R" Historically, across the nation there has not been health problems associated with the use of greywater. DEQ doesn't need to try to solve a problem that does not exist. The concern about washing diapers is unfounded. If the family is using enough soap and bleach to get the diapers clean, the wastewater will be safe for use as greywater. People that are willing to go to the work to use greywater are very passionate about water conservation and the environment. DEQ should not be making it difficult when it has been demonstrated that there are not health issues or water contamination issues resulting from the practice.

Tables 1 and 2 fail to take into account the national standards for low flow plumbing fixtures and energy efficient appliances. The daily flow numbers are all much higher than today's water consumption.

Figures 1-6 may look pretty and technical but are unnecessary with the requirements of Section 6 (c) and (d) being part of the regulation. They should be deleted.

Table 5 should allow two options. The first option should be to use the infiltration rate given for the soil type as determined from the NRCS County Soils Map for the location of the drainfield. The second option should be to perform percolation tests to determine the percolation rate. Table 5 is ridiculously detailed, far exceeding the accuracy or reproducibility of the specified percolation testing method. Table 5 should be simplified to not more than five loading rates, each rate based on a range of percolation test results.

Unfortunately this draft of Chapter 25 does not address the one common situation that has resulted in multiple illnesses and even death in Wyoming. That situation is the location of drainfields over fractured rock aquifers with water wells completed into the fractures.

Sincerely;



Louis B. Harmon PE-LS-PG



---

## Fwd: Draft comments to Small wastewater regulations

1 message

---

**William Tillman** <william.tillman@wyo.gov>

Fri, May 24, 2013 at 7:23 AM

To: Gina Johnson <gina.johnson@wyo.gov>, Frank Strong <frank.strong@wyo.gov>

----- Forwarded message -----

From: <[macysservices@cs.com](mailto:macysservices@cs.com)>

Date: Fri, May 24, 2013 at 7:01 AM

Subject: Draft comments to Small wastewater regulations

To: [william.tillman@wyo.gov](mailto:william.tillman@wyo.gov)

Dear Bill

Please find attached my recent comments to the recent draft of the Small Wastewater Regulations.

Thank you for allowing me to participate in this review.

Dwight Reppa

DBR Inc. dba Macy's Services

307.733.4687 (Office) 307.733.2108 (Fax)

[macysservices@cs.com](mailto:macysservices@cs.com)

[macysservices.com](http://macysservices.com)

--

William Tillman, P. E.  
Water and Wastewater Section  
Regulatory and Enforcement  
Herschler Building, 4-W  
122 West 25th Street  
Cheyenne, WY 82002  
(307) 777-6941  
(307) 777-6779 (FAX)  
[william.tillman@wyo.gov](mailto:william.tillman@wyo.gov)

"Live like there's no tomorrow. One day you'll be right"

E-Mail to and from me, in connection with the transaction of public business, is subject to the Wyoming Public Records Act and may be disclosed to third parties.

---

Wy Small Wastewater Reg. 4-26-13 draft comments.docx

18K

May 24, 2013

To: Mr. Bill Tillman  
DEQ/WQD  
Herschler Bldg. 4-W  
122 West 25<sup>th</sup> Street  
Cheyenne, WY 82002

From: Dwight Reppa  
Macy's Services  
Jackson, WY

Re: Review and Comments of the Draft of the Small Wastewater Regulations dated April 26, 2013.

Here are some comments regarding the current draft. My comments are based on my experience in pumping, repairing and installation of septic systems and grease interceptors. I believe my experiences in Teton, Lincoln and Sublette Counties are not unique to the rest of Wyoming. I believe other service providers/pumpers in Wyoming would agree with my comments. I hope other service providers/pumpers were able to make comments to the latest draft. It appeared that most of the previous comments were made by regulators and engineers. They probably would look at the regulations differently than a service provider/pumper would.

Sec. 9 (a) (iii) (A)

A 1000 gallon septic tank for a 6 bedroom home is too small if all the bedrooms are used. You are going to see more soil absorptions systems failing as a result of this change. Typically septic tank pumping is not done on a regular basis. If you want to keep this minimum, you should establish a pumping frequency based on solids accumulation in the septic tank. This opinion is based on my experience in the septic pumping business.

Sec. 9 (a) (iv) (D) (I)

The inlet and outlet baffle lengths need to be defined. An inlet baffle extended 1/3 into the liquid depth and the outlet baffle extending 9 inches below the liquid level could cause scum and or solids to carry out to the soil absorption area. The outlet baffle needs to be defined to extend to 1/3 of the liquid depth.

Sec. 9 (a) (viii)

Remove (small diameter) from the pressure distribution system sentence. I don't believe this was to be inserted there.

Sec. 9 (b) (i)

The dosing tank minimum opening should be increased to a 24 inch diameter opening. This is essential for access and maintenance of pumps, filters, siphons, etc. If you permit a 20 inch diameter opening it will be used. This smaller diameter opening is less expensive to use and may not allow for proper removal of pumps, filters and other equipment. We have experienced applications where a 20 inch riser was installed and the removal of pumps and equipment for maintenance or repair was difficult or impossible.

Sec. 9 (d) (vi)

The grease interceptor minimum openings should be increased to 24 inches in diameter. This is essential for pumping and cleaning. The liquid level of the grease interceptor accumulates a grease buildup on the walls of the tank and should be scraped off during the cleaning of the grease interceptor. A larger opening allows for a more effective cleaning of the grease interceptor.

Sec. 17 (b)

Septic tanks should be pumped as needed should be defined. As needed could be defined as when the system is failing or a percentage of the accumulation of the scum and sludge levels to the liquid depth of the tank. A recognized standard is 25%, but other percentages are used. Another standard is pumping your septic tank every 3 to 5 years based on occupancy. I believe you should make a recommendation in this section to help define a pumping frequency.





---

## Fwd: Chapter 25 Comments

1 message

---

**Frank Strong** <frank.strong@wyo.gov>  
To: Gina Johnson <gina.johnson@wyo.gov>

Tue, May 28, 2013 at 10:27 AM

Frank A Strong IV, P.E.  
SRF, Regulation and Enforcement  
Principal Engineer  
Wyoming DEQ - Water Quality Division  
122 W. 25th Street  
Herschler Building 4W  
Cheyenne, WY 82002  
307.777.6371  
[frank.strong@wyo.gov](mailto:frank.strong@wyo.gov)

----- Forwarded message -----

From: **James Brough** <[james.brough@wyo.gov](mailto:james.brough@wyo.gov)>  
Date: Thu, May 23, 2013 at 3:56 PM  
Subject: Chapter 25 Comments  
To: William Tillman <[william.tillman@wyo.gov](mailto:william.tillman@wyo.gov)>  
Cc: Frank Strong <[frank.strong@wyo.gov](mailto:frank.strong@wyo.gov)>, Rich Cripe <[rich.cripe@wyo.gov](mailto:rich.cripe@wyo.gov)>

Bill,

Below are some comments that Frank and I have discussed.

- The flow rates for mobile homes in Table 2 should be comparable to residential flows.
- In reference to the flows for meals at restaurants, the sizing of grease interceptors needs to be considered.
- Sizing for septic tanks should be 48 hours to allow 24 hour detention time after sludge and scum accumulation.

--

James S. Brough, P.E.  
Northwest District Engineer  
Water Quality Division

510 Meadowview Drive  
Lander, WY 82520  
[307-335-6961](tel:307-335-6961) (office)  
[307-332-7726](tel:307-332-7726) (fax)  
[james.brough@wyo.gov](mailto:james.brough@wyo.gov)

E-Mail to and from me, in connection with the transaction of public business, is subject to the Wyoming Public Records Act and may be disclosed to third parties.

E-Mail to and from me, in connection with the transaction of public business, is subject to the Wyoming Public Records Act and may be disclosed to third parties.



Fwd: Chapter 25 Comments

William Tillman <william.tillman@wyo.gov>  
To: Gina Johnson <gina.johnson@wyo.gov>

Fri, May 24, 2013 at 1:31 PM

----- Forwarded message -----

From: Seth Tourney <seth.tourney@wyo.gov>  
Date: Fri, May 24, 2013 at 1:22 PM  
Subject: Chapter 25 Comments  
To: William Tillman <william.tillman@wyo.gov>, Frank Strong <frank.strong@wyo.gov>

Hey Frank,

I was scanning the Chapter 25 document.

1. The proposed regulation does not specify when Advanced Treatment is required by the applicant. Under section 2 it discusses Advanced Treatment being required by a PE when proposed by the applicant; however, this regulation does not provide requirements when advanced treatment is required for the homeowner. Should Advanced Treatment be specified under Chapter 25 at all. All systems not specifically covered under Chapter 25 will require a professional engineer per Section 5 of the proposed draft.

2. Under Section 3 Pretreatment is defined but it does not appear that this is used within proposed regulation. Should this definition be removed from the draft?

Respectfully submitted,  
Seth

--  
Seth Tourney, P.E.  
Southeast District Engineer  
Wyoming Department of Environmental Quality  
Water Quality Division  
122 W. 25th Street  
Herschler Building, 4-W  
Cheyenne, WY 82002

E-Mail to and from me, in connection with the transaction of public business, is subject to the Wyoming Public Records Act and may be disclosed to third parties.

--  
William Tillman, P. E.  
Water and Wastewater Section  
Regulatory and Enforcement  
Herschler Building, 4-W  
122 West 25th Street  
  
Cheyenne, WY 82002  
(307) 777-6941  
(307) 777-6779 (FAX)  
[william.tillman@wyo.gov](mailto:william.tillman@wyo.gov)

"Live like there's no tomorrow. One day you'll be right"

E-Mail to and from me, in connection with the transaction of public business, is subject to the Wyoming Public Records Act and may be disclosed to third parties.





---

**Fwd: Comments on WQD Proposed Revisions, Chapter 25**

1 message

---

**William Tillman** <william.tillman@wyo.gov> Fri, May 24, 2013 at 3:31 PM  
To: Gina Johnson <gina.johnson@wyo.gov>, Frank Strong <frank.strong@wyo.gov>, Rich Cripe <rich.cripe@wyo.gov>

----- Forwarded message -----

From: **Bachelder, Richard** <[DBachelder@infiltratorsystems.net](mailto:DBachelder@infiltratorsystems.net)>  
Date: Fri, May 24, 2013 at 3:23 PM  
Subject: Comments on WQD Proposed Revisions, Chapter 25  
To: "william.tillman@wyo.gov" <[william.tillman@wyo.gov](mailto:william.tillman@wyo.gov)>  
Cc: "Lentz, Dave" <[dlentz@infiltratorsystems.net](mailto:dlentz@infiltratorsystems.net)>, "Thompson, Carl" <[cthompson@infiltratorsystems.net](mailto:cthompson@infiltratorsystems.net)>

Hello Mr. Tillman,

On behalf of Infiltrator Systems Inc. (Infiltrator) it is my pleasure to submit the attached comment document on the proposed revisions to the Water Quality Division, Water and Wastewater Section, Water Quality Rules and Regulations, Chapter 25, Small Wastewater Systems in response to the notice dated April 26, 2013.

I will forward hard copies of the enclosed electronic document via UPS to your attention later today.

Infiltrator appreciates the opportunity to provide comment, and for the Division's consideration of these concerns. If I can be of any assistance to you or others as you review these comments, please know that I will welcome all calls.

Sincerely,

Dick Bachelder

*Senior Regulatory Specialist*

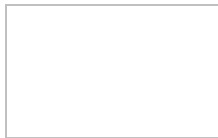

Infiltrator Systems, Inc.

71 Orchard Farm Road

York, ME 03909

800-616-8732 (o)

603-498-5306 (m)

[www.infiltratorsystems.com](http://www.infiltratorsystems.com)

 [www.facebook.com/infiltratorsystemsinc](http://www.facebook.com/infiltratorsystemsinc)

**Ch 25 Public Notice Comments for 6-14-13 WWAB Meeting 133**

 [www.linkedin.com/company/infiltrator-systems-inc](http://www.linkedin.com/company/infiltrator-systems-inc)

 <http://www.youtube.com/user/InfiltratorSysInc/videos>

This message contains PRIVILEGED AND CONFIDENTIAL INFORMATION intended solely for the use of the addressee(s) named above. Any disclosure, distribution, copying or use of the information by others is strictly prohibited. If you have received this message in error, please advise the sender by immediate reply and delete the original message.

--

William Tillman, P. E.  
Water and Wastewater Section  
Regulatory and Enforcement  
Herschler Building, 4-W  
122 West 25th Street  
Cheyenne, WY 82002  
(307) 777-6941  
(307) 777-6779 (FAX)  
[william.tillman@wyo.gov](mailto:william.tillman@wyo.gov)

"Live like there's no tomorrow. One day you'll be right"

E-Mail to and from me, in connection with the transaction of public business, is subject to the Wyoming Public Records Act and may be disclosed to third parties.

---

 **WY rulemaking comments\_II Tillman\_052413.pdf**  
1246K



May 24, 2013

Mr. William Tillman  
Wyoming Department of Environmental Quality  
Water Quality Division  
Hershler Building 4-W  
122 West 25<sup>th</sup> Street  
Cheyenne, WY 82002

Re: Comments on Proposed Revisions to the Water Quality Rules and Regulations  
Chapter 25, Small Wastewater Systems

Dear Mr. Tillman,

Infiltrator Systems Inc. (Infiltrator) appreciates the opportunity to make comment on the proposed revisions to the Water Quality Rules and Regulations, Chapter 25, Small Wastewater Systems.

We reference the most recent iteration of Chapter 25, which is labeled "Draft 4/19/13". Where applicable, we have also provided proposed text for the section under consideration. The comments are provided below by section number.

**Section 7. Drain Field Sizing:**

Section 7(b) addresses the issue of total infiltrative area provided by standard trenches (perforated pipe embedded in aggregate), chamber trenches, and bed systems. Subsection (i) of 7(b) details the calculation to be utilized to determine the infiltrative area for standard trenches (perforated pipe and aggregate) in part as follows:

*"...the total infiltrative surface area shall be calculated by multiplying the total length of the trench (ft) by the sum of the bottom width (ft) and the height (ft) of each sidewall."*

Subsection (ii) of 7(b) details the calculation to be utilized to determine the infiltrative area for chamber trenches in part as follows:

*"...the total infiltrative surface area shall be calculated by multiplying the total length of the trench (ft) by the sum of the bottom width (ft) of the chamber and the height (ft) of each sidewall."*

The calculations as proposed in Section 7(b)(i) and (ii) to determine infiltrative area for standard (pipe and aggregate) trenches and chamber trenches are virtually identical. There is no other language in the proposed regulations which relates to chamber system sizing. Therefore, the regulations as proposed eliminate DEQ's 25-year-old policy of sizing chamber systems with "equivalent area" (or reduced) sizing.

Without well-documented performance concerns, we strongly assert that DEQ's proposal to eliminate the "equivalent area" sizing of gravelless chamber systems is wholly unsupported and, as such, unjustified.

The following statements are fact:

- Chambers have an extensive history of use in Wyoming, spanning 25 years, at “equivalent area” (reduced) sizing. Please consider:
  - In a memorandum dated May 27, 1988, DEQ allowed the permitting of plastic chambers manufactured by Infiltrator using a 0.6 multiplier (see enclosed copy, labeled “Attachment 1”). This amounts to an approximate 40% reduction in system sizing as compared to standard (pipe and aggregate) system sizing;
  - In a memorandum dated November 21, 1994, DEQ established Policy #13.41.2 (copy enclosed, labeled “Attachment 2”). This policy allows the use of approved chamber products with “equivalent area” sizing, which translates to an approximate 50% reduction in system sizing as compared to standard pipe and stone system sizing. This policy remains in effect today;
- Policy #13.41.2 defines “equivalent area” sizing as follows:

“...gravelless leachfield chambers get double infiltrative surface area credit for the bottom area of the chamber. This is allowed because research indicates that chambers provide an optimum infiltrative surface by eliminating the 50% stone masking associated with conventional systems utilizing stone in the leach field.”
- A significant number of studies, based upon independent, third-party testing, prove that reduced-size gravelless chamber systems perform consistent with conventional pipe and stone systems while providing equivalent wastewater treatment; (See bibliography enclosed, labeled “Attachment 3”);
- The only national standard relating to gravelless chambers – the International Association of Plumbing and Mechanical Officials (IAPMO) Uniform Plumbing Code (UPC) – allows a 30% reduction (or 0.70 multiplier) for chamber technology (Excerpt enclosed, labeled “Attachment 4”);
- 48 of the 50 states and 10 Canadian provinces allow the use of plastic chambers at equivalent area (reduced) sizing;
- No other state has fully eliminated the use of chamber systems at previously issued reduced system sizing;
- There are more than 19,500 Infiltrator-brand chamber leachfields in the ground in Wyoming today; and
- Infiltrator has a total of 12 warranty claims on file at present, dating as far back as 1995. Of the 12 warranty claims:
  - 3 were found to be due to trench bottom installation too close to the groundwater table
  - 2 were due to incorrect soil characterization (resulting in undersizing)
  - 3 resulted from installation errors
  - 1 was damaged by gophersThis leaves 3 systems as malfunctioning for unexplained reasons, and translates to a 99.98% rate of successful long-term chamber performance under the DEQ's historical sizing policies.

These facts make our case. “Equivalent area” sizing of chamber systems – that is, reduced system sizing for chamber leachfields as compared to standard (pipe and aggregate) leachfields – has been common practice in Wyoming for 25 years. Reduced system sizing for chamber leachfields as compared to standard (pipe and aggregate) leachfields is common practice throughout North America. The only national standard in place today with respect to chamber system sizing recommends “equivalent area” sizing. Both laboratory and full-scale field studies support the claim that reduced-size chamber systems perform as well as standard (pipe and aggregate) systems. Tens of

thousands of chamber systems have been installed in Wyoming since 1988, and over 3 million Infiltrator chamber leachfields have been installed at "equivalent area" sizing across North America over the past quarter century.

***We submit that without well-documented evidence of significant performance issues, there is no valid reason to modify chamber system sizing in any state, including Wyoming. We are aware of, and DEQ has produced, no such documentation.***

Please consider the following, taken from the DEQ-produced document titled: "RULE MAKING OUTREACH DOCUMENT, Responses to Stakeholder Comments For Comment Period Ending March 1, 2013, Wyoming Water Quality Rules and Regulations, Chapter 25, Small Wastewater Systems" (RULE MAKING OUTREACH DOCUMENT):

*Comment: "The sidewall height in the infiltrative area calculation is not being used typically anymore. I believe this should be removed from the calculation."*

*DEQ Response: The WAD has used bottom and sidewall area for the absorption surface for many decades with one of the lowest failure rates in the country for small wastewater systems. With this success rate there is no reason to change just because other parts of the country are doing something different.*

With more than 19,500 chamber systems in the ground in the state, *thousands* of chamber systems would have had to have malfunctioned during the last 25 years for the failure rate to be considered problematical. DEQ's own comment (above) indicates that failure rates for small wastewater systems in Wyoming are amongst the lowest in the country. Infiltrator's own data supports this, in that we have formally followed-up on a total of 12 warranty claims in the state. (We pride ourselves on our commitment to working with any homeowner who is experiencing valid chamber system performance issues.) It is clear that the failure rate of chamber systems in the state of Wyoming is miniscule.

Furthermore, we agree with the DEQ in the first half of the final sentence in the above-referenced comment as well: "With this success rate there is no reason to change...".

We are aware of absolutely nothing that validates, and DEQ has offered no substantive support for, the modification of the sizing criteria of chambers systems in Wyoming as proposed in Chapter 25 as drafted. However, in the spirit of cooperation and collaboration we would recommend the following:

Colorado has allowed chamber systems for as long as Wyoming, with very similar sizing criteria. The Water Quality Control Division of the Colorado Department of Environmental Quality has allowed chamber trench systems to be sized at a 50% reduction, and chamber bed systems be sized at a 40% reduction, in infiltrative area as compared to the respective conventional pipe and aggregate systems. 5 CCR 1002-43 has just been completely rewritten, with significant changes having been made to many sections of the regulation. We find the process here in Wyoming of creating Chapter 25 from Chapter 11 as being very similar in many ways.

The new, revised regulations in Colorado have incorporated the IAPMO UPC standard for chamber systems – that is, a 0.70 multiplier (which amounts to a 30% infiltrative area reduction) when sizing chamber systems as compared to what is required for a conventional pipe and aggregate system. (We provide a copy of Table 10-3 from the new regulations, which is titled "Size Adjustment Factors for Types of Distribution Media in Soil Treatment Areas Accepting Treatment Level 1 Effluent", herein under "Attachment 5"). Infiltrator participated in the process in Colorado, and we are comfortable with the chamber system sizing criteria in these new regulations.

In an effort to work with the state, Infiltrator recommends that the same sizing criteria be adopted in Wyoming as well. This would honor the breadth of scientific support for reduced chamber system sizing,



which is of the utmost importance to our company. At the same time it should offer critics of "equivalent area" sizing of chamber systems – regardless of their justification and whoever they may be – some solace. That stated, we cannot accept complete elimination of reduced chamber system sizing as presently proposed.

To accomplish this, Section 7 might be modified by inserting a new subsection between existing subsections (b) and (c) which reads:

*(c) Chamber system sizing adjustment*

*(i) Chamber system sizing shall be determined by calculating the total infiltrative surface area in accordance with subsection (a) above, applying a 0.70 multiplier to this value, then applying the calculations as described in subsection (b).*

Existing subsections (c) and (d) would be modified to (d) and (e) respectively.

Finally, we submit under "Attachment 6" a copy of an email (with attachments listed for reference) that was submitted on behalf of Infiltrator by Mr. David Lentz, P.E., the company's Director of Government Relations. Mr. Lentz sent this information to Mr. James Brough, P.E., of the Wyoming DEQ on August 8, 2012. It was submitted with the intent (as his email reads) of establishing Infiltrator's position early in the regulatory revision process. These comments were not presented in the *RULE MAKING OUTREACH DOCUMENT* and are critical to the scientific evaluation of chamber sizing in Wyoming. We submit this information again at this time both in support of the above comments and recommendation, as well as to be on record as having provided substantive technical input well before this final phase of review.

### **Section 9. Septic Tanks and Other Treatment Tanks:**

#### **Section 9(a)(i) – Septic tanks:**

This section contemplates septic tanks manufactured using concrete and fiberglass or an approved material. Approximately 1 in 10 septic tanks installed in North America is fabricated using thermoplastic materials (polypropylene or polyethylene). The use of thermoplastic tanks is a growing national trend. As such, Infiltrator proposes the addition of this material to the Wyoming rules, as follows:

*Septic tanks shall be fabricated or constructed of concrete, fiberglass, thermoplastic, or an approved material...*

#### **Section 9(a)(C)(iii) – Size:**

Section 9(a)(C)(iii) allows the use of a 1,000-gallon tank for up to a 6-bedroom home. Using the daily flow values in Table 1 of the draft rule, the hydraulic residence times by number of bedrooms are as follows:

- 4 bedroom = 1,000 gallons / 470 gallons/day = 2.12 days
- 5 bedroom = 1,000 gallons / 550 gallons/day = 1.81 days
- 6 bedroom = 1,000 gallons / 630 gallons/day = 1.59 days

As a "rule of thumb", most states use a minimum hydraulic residence time of 2 days or 48 hours in the design of primary treatment units such as septic tanks. Shortening the residence time of effluent in the septic tank will reduce the time for settling of solids and flotation of solids, fats, oils, and grease. With reduced settling, the total suspended solids concentration in the septic tank effluent will have the potential to elevate, resulting in increased risk of the soil absorption system clogging with solids. Once the interstitial space of the soil absorption system clogs with solids, the drainfield's hydraulic capacity will be compromised, thereby reducing its life expectancy.

Infiltrator suggests leaving the 1,000-gallon minimum working volume in place for 4 bedrooms, increasing the 5-bedroom working capacity to 1,250 gallons (2.3 days residence time), and using a 1,500-gallon (2.4 days residence time) tank for 6 bedrooms. These size increments are consistent with tank sizing across the United States.

Section 9(a)(C)(iv)(B) – Configuration:

Infiltrator commends the DEQ for lowering the minimum liquid level from 4 feet to 3 feet in Section 9(a)(C)(iv)(B). This liquid level requirement is consistent with rule and policy in 48 states. We suggest separating the liquid level requirement from the requirements for 2-compartment tanks at the beginning of Section 9(a)(C)(iv)(B) to make the requirement applicable to single-compartment tanks. The liquid level requirement could become item Section 9(a)(C)(iv)(C), with other subsection lettering adjusted accordingly.

Section 9(a)(C)(iv)(D)(I) – Configuration:

Section 9(a)(C)(iv)(D)(I) limits the penetration depth of tees and baffles to no more than 1/3 the liquid depth. Assuming that the inlet and outlet tees and baffles are intended to direct sewage into the tank and allow effluent to exit the tank from within the clear zone that exists between the sludge and scum, the use of the middle 25% of the liquid height will establish a reasonable range for manufacturers to meet. This range is established in the IAPMO/ANSI Z1000-2013 ballot draft<sup>1</sup> (see excerpt under "Attachment 7"), which states:

**4.7.3**

*The fitting inlets or the centroid of the openings shall be located between 50% and 75% of the liquid depth, measured from the inside floor of the tank.*

The IAPMO/ANSI Z1000-2013 ballot draft document has successfully been balloted by the IAPMO Plumbing Standards Committee and is scheduled for publication in the fall of 2013. This will be the American National Standard for prefabricated septic tank manufacturing. Infiltrator suggests establishing a similar range of baffle and tee penetration in the Wyoming rules, as follows:

- (I) The tees or baffles shall
  - a. extend a minimum of six (6) inches above the liquid level; and
  - b. extend within 50% and 75% of the liquid depth below the liquid level, measured from the inside floor of the tank.

Section 9(a)(C)(iv)(D)(II) – Configuration:

Section 9(a)(C)(iv)(D)(II) requires a minimum of 3 inches of clear space over the top of the baffles or tees. Many states use less than 3 inches of clear space above the top of baffle or tee. IAPMO/ANSI Z1000-2007, which is the version of the American National Standard for septic tank manufacturing that is being used at present, requires 2 inches of space, as follows (see excerpt labeled, "Attachment 8"):

**3.5.2**

*Septic tanks shall have an air space equal to not less than 10 percent of the liquid volume, and total depth shall not be less than 9 in. (23 cm) above the liquid level. There shall be a minimum of 2 in. (5 cm) of separation between the top of the tank and the top of the sanitary tee vent opening.*

The IAPMO/ANSI Z1000-2013 ballot draft reduced the 2-inch gap to a minimum of 1 inch, as follows (see excerpt under "Attachment 7"):

**4.6.2**

*There shall be a separation of at least 25 mm (1 in) between the top of the tank and the top of the inlet and outlet device vent opening.*

Infiltrator suggests the use of 1 or 2 inches as a minimum space above the top of baffle or tee. This gap will certainly meet the objective, which is to promote air flow and prevent a vapor lock from occurring. Adding space beyond 2 inches will provide no material benefit in air flow or tank performance, but will in fact increase the amount of material a septic tank manufacturer

---

<sup>1</sup> Questions about the status or content of IAPMO/ANSI Z1000-2013 can be directed to Mr. Abraham Murra, P.E., Director of Standard at the International Association of Plumbing and Mechanical Officials. Mr. Murra can be reached at (909) 472-4106 or [abraham.murra@iapmort.org](mailto:abraham.murra@iapmort.org).

needs to use for fabrication of a tank, which is a burdensome and unnecessary requirement in a time of difficult economic circumstances.

Section 9(a)(C)(iv)(D)(III) – Configuration:

Section 9(a)(C)(iv)(D)(III) requires the outlet elevation to provide a minimum distance of 9 inches or 20 percent of the liquid depth, whichever is greater, between the top of the liquid and the bottom of the septic tank cover for scum storage and the venting of gases. Nationally, only Wyoming, Montana, North Dakota, and South Dakota require 20% airspace (see analysis under "Attachment 9"). All other states either have a lower airspace requirement or stipulate a minimum distance from liquid to top of tank. The most common minimum airspace is 15%, with the minimum 9-inch space also being a common requirement in state rules. IAPMO has established a minimum of 10% or 9 inches. The Canadian Standards Association has established a minimum of 10% of the working capacity of the tank in standard CSA B66-10, which is the Canadian equivalent of IAPMO/ANSI Z1000.

Infiltrator proposes amending the minimum allowable airspace requirement to allow the manufacturer the option of using 20% or 9 inches. This would eliminate the "whichever is greater" clause from the rule. Under either scenario, adequate provisions will be in place within the tank for the retention of scum (floating solids). Note that Section 9(a)(C)(iv)(D)(I) already requires tees and baffles to extend a minimum of 6 inches above the liquid level to prevent scum from exiting the tank and entering the soil absorption system. Having an additional 6 inches of space above the outlet tee or baffle will be sufficient for air flow within the tank. The proposed amendment is as follows:

*(III) The inlet pipe shall be at least two (2) inches higher than the outlet pipe. The outlet elevation shall be designed to provide a minimum distance of nine (9) inches or twenty (20) percent of the liquid depth, ~~whichever is greater~~, between the top of the liquid and the bottom of the septic tank cover for scum storage and the venting of gases.*

On a related note, we suggest adding a requirement for a minimum freeboard of 6 inches on the baffle for a 2-compartment tank to restrict scum from migrating from the first to second compartment.

Section 9(a)(C)(v)(B):

Section 9(a)(C)(v)(B) requires riser covers terminating above grade to have an approved "locking device". Methods for securing riser covers other than locks are commonplace in the onsite wastewater market and allowed across North America. Infiltrator suggests adjusting the language to expand the definition of "secure". The IAPMO/ANSI Z1000-2013 ballot draft includes the following language (excerpt provided under "Attachment 7"):

**4.10 Covers**

*Openings shall be capable of accommodating covers (i.e., lids) that*

*(a) are watertight;*

*(b) are secure;*

*Note: Acceptable measures for securing covers include padlock(s), covers that can be removed only with tools, or covers with a mass of at least 30 kg (66 lb).*

Infiltrator's suggested alternative language for the Wyoming rules is as follows:

*(B) The riser shall terminate at a maximum of six (6) inches below the ground surface. Riser covers terminating above grade shall ~~have an approved locking device. have a locking device, only be removable with tools, have a minimum weight of 66 pounds, or provide another approved method of being secured.~~*

**Other tank comments** – The Oklahoma rules (Section 252:641-7-2. Types of tanks) address the use of thermoplastic and fiberglass tanks, requiring certification by IAPMO or CSA. Note that Oklahoma, Utah, North Carolina, New Jersey, and Maine require CSA certification of thermoplastic tanks. Infiltrator suggests adopting the Oklahoma DEQ's rule language, as follows:

Fiberglass and plastic tanks shall meet either IAPMO or CSA standards for septic tanks and shall be installed according to the manufacturer's recommendations. If the tank does not bear the IAPMO or CSA mark, then the installer must submit documentation from IAPMO or CSA stating the tank meets the applicable standard.

We look forward to the public hearing to be held on June 14, 2013 in Casper. If you or others have any questions or concerns about these comments, or would like to be provided with any additional information in the meantime, please know that we will welcome your call.

Sincerely,

A handwritten signature in black ink that reads "Dick Bachelder". The signature is written in a cursive style with a long horizontal flourish extending to the right.

Dick Bachelder  
Senior Regulatory Specialist  
603-498-5306

cc: Mr. James Brough, P.E., WY Water Quality Division  
Mr. David Lentz, P.E., Infiltrator Systems Inc.  
Mr. Eric Berquist, Infiltrator Systems Inc.  
Mr. Matt Gibbs, Infiltrator Systems Inc.

Attachment 1

1988 WQD Chamber Sizing Policy



THE STATE OF WYOMING

MIKE SULLIVAN  
GOVERNOR

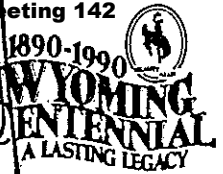
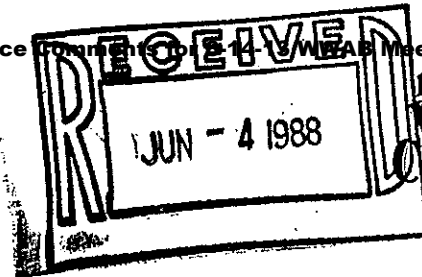

# Department of Environmental Quality

Administration  
(307) 777-7937

Air Quality Division  
(307) 777-7391

Land Quality Division  
(307) 777-7756

Solid Waste Management Program  
(307) 777-7752

Water Quality Division  
(307) 777-7781

## MEMORANDUM

TO: Delegated Small Wastewater Permitting Agencies and Water Quality District Engineers

FROM: Larry Robinson, Engineering Supervisor, Water Quality Division *LR*

DATE: Leaching Chambers, Section 16.41, Policies and Procedures Manual

SUBJECT: May 27, 1988

Infiltrator System Inc. has submitted research literature, operating data and rules and regulations from other states concerning the use of leaching chambers. This system is intended to replace the standard trench and bed subsurface treatment system or leach field. The system involves the use of an inverted chamber used to protect the infiltration surface and does not require the use of stone. The system allows an adjustment to the required infiltrative surface area because the surface is protected from "stone masking" which reduces the effective infiltration area available in a standard gravel trench or bed.

After review of the submitted material this office is prepared to issue permits authorizing the use of Infiltrator and comparable leaching chamber systems in undelegated counties. In delegated counties, the use of these systems is dependent upon acceptance by the local agency. Each delegated agency has the authority, as outlined in the delegation agreement, to approve or reject the use of these systems.

The state will utilize the following criteria to evaluate applications for leaching chamber systems:

1. A leaching chamber system may be constructed in lieu of a standard trench or bed subsurface disposal system. The system must be preceded by a septic tank that meets the requirements of Section 39, Chapter XI, Pretreatment.
2. The leaching chamber shall be constructed of durable material not subject to excessive corrosion and structurally capable of supporting the loads to which it shall be subjected. If the system is subject to vehicular traffic the chambers shall be designed to comply with AASHTO rating H-20 of 32,000 lbs/axle.

3. A minimum of twelve inches of soil cover shall be placed over the tops of the chambers.
4. When installed in a trench configuration the minimum distance between walls of adjacent trenches shall be 3 feet.
5. End plates are required at the inlet and downstream end of the chambers.
6. The bottom of the trench or bed shall be level and scarified.
7. For gravity systems the inlet pipe shall extend through the end plate and terminate on an adequate splash plate or block.
8. For pressure distribution systems perforated PVC pipe extending the length of the chamber is required.
9. Sizing of the required infiltration surface area shall be determined using the methods established in Chapter XI for trench systems. This area is adjusted by a multiplier of 0.6 in order to allow for the lack of "stone masking" under the leaching chamber. This multiplier is based upon 3 foot trench and assumes 50% masking. The area for bed systems utilizing leaching chambers shall be calculated assuming no bottom masking under the chamber and 50% masking for the chamber sidewall.
10. All other applicable requirements of Chapter XI shall remain unchanged.

/jt

cc: Jim Nichols, Infiltrator Systems Inc.

Attachment 2

1994 WQD Chamber Sizing Policy #13.41.2





THE STATE OF WYOMING

MIKE SULLIVAN  
GOVERNOR



# Department of Environmental Quality

1043 Coffeen Avenue, Suite D • Sheridan, Wyoming 82801

AIR QUALITY  
(307) 672-  
Fax (307) 672-0050

LAND QUALITY  
(307) 672-6488  
Fax (307) 672-2213

WATER QUALITY  
(307) 672-8487  
Fax (307) 674-6060

## MEMORANDUM

**TO:** District Engineers  
Delegated Small Wastewater Permitting Agencies

**THROUGH:** Larry Robinson *LR*

**FROM:** Brian Mark *Bm*

**DATE:** November 21, 1994

**SUBJECT:** Sizing for Leachfield Chamber Systems. Revised Policy 13.41.2.

The following is intended to clarify and expand on the sizing criteria contained in the May 27, 1988 memo on the referenced subject.

Sizing of leachfields utilizing chamber systems is based on the following:

1. The total infiltrative surface of the soil absorption system is determined using the criteria in Section 38, Chapter XI of Wyoming Water Quality Rules and Regulations.
2. The total infiltrative surface determined from Section 38 is the sum of the bottom area and the sidewall area below the invert of the distribution pipe and is based on a system utilizing stone and not a chamber.
3. Documented research indicates that chambers provide an optimum infiltrative surface by eliminating the 50% stone masking associated with conventional systems utilizing stone in the leachfield.
4. Eliminating the stone masking by use of a chamber system is equivalent to doubling the infiltration effectiveness of the bottom area under the chamber.

Sizing for Leaching Chamber Systems. Revised Policy 13.41.2  
Page 2 of 3

5. The masking factor is only applicable to the bottom area under the chambers and should not be utilized to adjust the sidewall area used to meet the total infiltrative surface determined utilizing Section 38.
6. The effective infiltrative area can be determined by doubling the bottom area under the chamber and adding the unadjusted sidewall area. The effective infiltrative area is dependent upon the dimensions of the chamber and the system layout as a bed or a trench configuration.
7. The effective area should be compared directly to the total infiltrative surface as determined utilizing Section 38. This may be accomplished by one of the methods described below.

The manufacturers' recommended 50% masking factor, which is applicable to bottom area only, cannot be directly applied to the Section 38 total infiltrative surface which includes both bottom and sidewall area. The following illustrates calculating the correct size of a leachfield utilizing leaching chambers in a trench configuration for compliance with the state Section 38 standard for total infiltrative area.

The use of leaching chambers doubles the effective infiltration capability of the bottom area. As stated above, sidewall area is not affected. The effective infiltrative area per lineal foot of a trench system equals sidewall plus two times the bottom width plus sidewall times unit length, or

$$\text{AREA}_{\text{chamber}}/\text{LF} = [\text{sidewall} + (2 \times \text{bottom width}) + \text{sidewall}] \times 1'/\text{LF}$$

For purposes of illustration assume a Section 38 total infiltrative surface of 1,000 square feet is required and a typical chamber will be used. This particular chamber has a width of 34", a sidewall of 6" and a length of 75" (for trench configurations a length of 72" will be used based on available sidewall reduced by the overlap connection). Using the above formula the effective infiltrative area per lineal foot of chamber is the following:

$$\text{AREA}_{\text{chamber}}/\text{LF} = [0.5' + (2 \times 34"/12) + 0.5'] \times 1'/\text{LF} = 6.6 \text{ SF/LF}$$

The length of trench can now be determined by dividing the total required infiltrative surface area, determined in accordance with Section 38, by the effective infiltration area per unit foot.

$$\text{TRENCH LENGTH} = \text{AREA}_{\text{required}}(1,000 \text{ SF}) / 6.6 \text{ SF/LF} = 150 \text{ LF}$$

The number of chamber units needed is obtained by dividing the

Sizing for Leaching Chamber Systems. Revised Policy 13.41.2  
Page 3 of 3

length of trench required (150 LF) by the length of the chamber (6 LF), or

$$\text{CHAMBER UNITS} = 150 \text{ LF} / 6 \text{ LF/UNIT} = 25 \text{ UNITS}$$

The total effective infiltrative area of a chamber used for a trench system is

$$\text{AREA}_{\text{CHAMBER}} = 6.6 \text{ SF/LF} \times 6 \text{ LF/UNIT} = 40 \text{ SF/UNIT}$$

An alternative method of calculating the number of chamber units is to divide the Section 38 infiltrative surface area by 40 square feet/unit, or

$$\text{CHAMBER UNITS} = 1000 \text{ SF} / 40 \text{ SF/UNIT} = 25 \text{ UNITS}$$

When determining the total effective infiltrative area of a chamber bed system the sidewall area can be ignored. This does not significantly increase the size of the bed. When the sidewall is ignored the total effective infiltrative area of a chamber is

$$\text{AREA}_{\text{CHAMBER}} = [(34/12)' \times 2] \times 6.25 \text{ LF/UNIT} = 35.4 \text{ SF/UNIT}$$

Using the same example of Section 38 infiltrative surface the number of chamber units required for a bed can be obtained by dividing the 1,000 square feet infiltrative surface by 35.4 square feet/unit, or

$$\text{CHAMBER UNITS} = 1000 \text{ SF} / 35.4 \text{ SF/UNIT} \approx 28 \text{ UNITS}$$

The actual layout of the bed could be any configuration totaling 28 units (i.e. 4x7, 14x2, etc.). This meets Section 38 requirements utilizing the minimum number of chamber units.

BDM/bm

Attachment 3

Chamber Treatment and Performance Study Bibliography

Research Summary on Infiltration Efficiency of Gravelless Chamber Drainfields  
Compared to Gravel Aggregate Drainfields

Research Study	Description of Study
Rock, et. al. 2009. Longevity of Convention Gravel and Reduced Area Chamber Distribution Systems Installed in the Town of Cumberland, Maine 1975 to 1988, Proceedings of NOWRA	Chamber longevity study on systems sized at 50% reduction; systems aged at least 20, and up to 30 years.
Lowe et al. 2008. Controlled Field Experiment for Performance Evaluation of Septic Tank Effluent Treatment during Soil Evaluation, Journal of Environmental Engineering	Two-year field study of 30 pilot-scale test cells.
Walsh, R. 2006. Infiltrative Capacity of Receiving Media as Affected by Effluent Quality, Infiltrative Surface Architecture, and Hydraulic Loading Rate, Master Thesis at Colorado School of Mines	One dimensional column study
Uebler et al. 2006. Performance of Chamber and EZ1203H Systems Compared to Conventional Gravel Septic Tank Systems in North Carolina, Proceedings of NOWRA	Field evaluation of failure rates of approximately 300 of each type system (gravel, chamber, EPS) 2-12 years old
Radcliffe et al. 2005. Gravel and Sidewall Flow Effects in On-Site System Trenches, Soil Science Society of America Journal	Two dimensional computer model (HYDRUS-2D)
Siegrist et al. 2004. Wastewater Infiltration into Soil and the Effects of Infiltrative Surface Architecture, Small Flows Quarterly	Two one dimensional column studies and pilot-scale field study
White and West. 2003. In-Ground Dispersal of Wastewater Effluent: The Science of Getting Water into the Ground. Small Flows Quarterly, 2003	Literature Review and One dimensional column study measuring the impact of gravel and fines (clean water)
King et al. 2002. Surface Failure Rates of Chamber and Traditional Aggregate-Laden Trenches in Oregon, Small Flows Quarterly	Field evaluation of failure rates of 198 chamber systems and 191 gravel systems 2-5 years old
Burcham, T. 2001. A Review of Literature and Computations for Chamber-Style Onsite Wastewater Distribution Systems, Report commissioned by the Mississippi Department of Health	Literature review and computer model
Joy, Douglas. 2001. Review of Chamber Systems and Their Sizing for Wastewater Treatment Systems, Ontario Rural Wastewater Centre Report, University of Guelph	Literature Review
Van Cuyk et al, 2001. Hydraulic and Purification Behaviors and their Interactions During Wastewater Treatment in Soil Infiltration Systems", Journal of Water Resources	Three-dimensional lysimeter study of treatment performance
Casper, Jay. 1997. Final Report: Infiltrator Side-by-Side Test Site, Killarney Elementary School, Winter Park, Florida. Report to State of Florida, Department of HRS.	Pilot-scale side-by-side study of 15 trenches (gravel and chamber).
Amerson, RS, Tyler, EJ, Converse, JC. 1991. Infiltration as Affected by Compaction, Fines and Contact Area of Gravel, <i>in</i> On-Site Wastewater Treatment: Proceedings of 6 <sup>th</sup> National Symposium On Individual and Small Community Sewage Systems, American Society of Agricultural Engineers, St. Joseph, MI, December 1991	Evaluation of 30 soil cells to assess impact of gravel compaction, contact area and fines.
Siegrist, Robert. 2006. Evolving a Rational Design Approach for Sizing Soil Treatment Units, Small Flows Quarterly. Summer 2006	Proposed design methodology that takes into account BOD loading, soil type and infiltrative surface architecture.
2001. U.S. EPA Decentralized Systems Technology Fact Sheet – Septic Tank Leaching Chambers.	Literature Review and Recommended Usage

Attachment 4

IAPMO UPC Excerpt – Chamber Sizing

Ch 25 Public Notice Code

AN AMERICAN NATIONAL STANDARD  
IAPMO/ANSI UPC 1 - 2012

# 2012 UNIFORM PLUMBING CODE®



TABLE H 2.1(3)  
LEACHING AREA SIZE BASED ON SEPTIC TANK CAPACITY

REQUIRED SQUARE FEET OF LEACHING AREA PER 100 GALLONS SEPTIC TANK CAPACITY (square feet per 100 gallons)	MAXIMUM SEPTIC TANK SIZE ALLOWABLE (gallons)
20-25	7500
40	5000
90	3500
120	3000

For SI units: 1 square foot per 100 gallons = 0.000245 m<sup>2</sup>/L, 1 gallon = 3.785 L

the underground water stratum that is usable for domestic purposes.

**Exception:** In areas where the records or data indicate that the groundwaters are grossly degraded, the 5 foot (1524 mm) separation requirement shall be permitted to be reduced by the Authority Having Jurisdiction. The applicant shall supply evidence of groundwater depth to the satisfaction of the Authority Having Jurisdiction.

- (4) The minimum effective absorption area in any seepage pit shall be calculated as the excavated sidewall area below the inlet exclusive of any hardpan, rock, clay, or other impervious formations. The minimum required area of porous formation shall be provided in one or more seepage pits. No excavation shall extend within 10 feet (3048 mm) of the water table nor to a depth where sewage is capable of contaminating underground water stratum that is usable for domestic purposes.

**Exception:** In areas where the records or data indicate that the groundwaters are grossly degraded, the 10 foot (3048 mm) separation requirement shall be permitted to be reduced by the Authority Having Jurisdiction.

The applicant shall supply evidence of groundwater depth to the satisfaction of the Authority Having Jurisdiction.

- (5) Leaching chambers shall be sized on the bottom absorption area (nominal unit width) in square feet. The required area shall be calculated using Table H 2.1(2) with a 0.70 multiplier.

**H 4.0 Percolation Test.**

**H 4.1 Pit Sizes.** Where practicable, disposal field and seepage pit sizes shall be computed from Table H 2.1(2). Seepage pit sizes shall be computed by percolation tests, unless use of Table H 2.1(2) is approved by the Authority Having Jurisdiction.

**H 4.2 Absorption Qualities.** In order to determine the absorption qualities of seepage pits and of questionable soils other than those listed in Table H 2.1(2), the proposed site shall be subjected to percolation tests acceptable to the Authority Having Jurisdiction.

**H 4.3 Absorption Rates.** Where a percolation test is required, no private disposal system shall be permitted to serve a building where that test shows the absorption capacity of the soil is less than 0.83 gallons per square foot (gal/ft<sup>2</sup>) (33.8 L/m<sup>2</sup>) or more than 5.12 gal/ft<sup>2</sup> (208.6 L/m<sup>2</sup>) of leaching area per 24 hours. Where the percolation test shows an absorption rate greater than 5.12 gal/ft<sup>2</sup> (208.6 L/m<sup>2</sup>) per 24 hours, a private disposal system shall be permitted where the site does not overlie groundwaters protected for drinking water supplies, a minimum thickness of 2 feet (610 mm) of the native soil below the entire proposed system is replaced by loamy sand, and the system design is based on percolation tests made in the loamy sand.

**H 5.0 Septic Tank Construction.**

**H 5.1 Plans.** Plans for septic tanks shall be submitted to the Authority Having Jurisdiction for approval. Such plans shall show dimensions, reinforcing, structural calculations, and such other pertinent data as required.

**H 5.2 Design.** Septic tank design shall be such as to produce a clarified effluent consistent with accepted standards and shall provide adequate space for sludge and scum accumulations.

**H 5.3 Construction.** Septic tanks shall be constructed of solid durable materials not subject to excessive corrosion or decay and shall be watertight.

**H 5.4 Compartments.** Septic tanks shall have not less than two compartments unless otherwise approved by the Authority Having Jurisdiction. The inlet compartment of any septic tank shall be not less than two-thirds of the total capacity of the tank, nor less than 500 gallons (1892 L) liquid capacity, and shall be not less than 3 feet (914 mm) in width and 5 feet (1524 mm) in length. Liquid depth shall be not less than 2½ feet (762 mm) nor more than 6 feet (1829 mm). The secondary compartment of a septic tank shall have a capacity of not less than 250 gallons (946 L) and a capacity not exceeding one-third of the total capacity of such tank. In septic tanks having a 1500 gallon (5678 L) capacity, the secondary compartment shall be not less than 5 feet (1524 mm) in length.

**H 5.5 Access.** Access to each septic tank shall be provided by not less than two manholes 20 inches (508 mm) in minimum dimension or by an equivalent removable cover



Attachment 5

Colorado Regulations – Excerpt Sizing Table 10-3

**WATER QUALITY CONTROL DIVISION  
PROPONENT'S PREHEARING VERSION INCLUDING  
REBUTTAL STATEMENT PROPOSALS AS PRESENTED IN  
STATE SUMMARY FOR THE MARCH 12, 2013 HEARING AND  
COMMISSIONER CHANGES AT THE  
MARCH 12, 2013 HEARING**

**REDLINES FOR COMMISSIONER FORMATTING AND EDITS**

**DEPARTMENT OF PUBLIC HEALTH AND ENVIRONMENT**

**Water Quality Control Commission**

**ON-SITE WASTEWATER TREATMENT SYSTEM REGULATION**

**5 CCR 1002-43**

**43.1 Authority**

This regulation is promulgated pursuant to the On-site Wastewater Treatment System Act, 25-10-101, et seq. C.R.S.

**43.2 Scope and Purpose**

**A. Declaration**

1. In order to preserve the environment and protect the public health and water quality; to eliminate and control causes of disease, infection, and aerosol contamination; and to reduce and control the pollution of the air, land and water, it is declared to be in the public interest to establish minimum standards and regulations for On-site Wastewater Treatment Systems (OWTS) in the state of Colorado and to provide the authority for the administration and enforcement of such minimum standards and regulations.
2. This regulation shall apply to On-site Wastewater Treatment Systems as defined in section 25-10-103(12), C.R.S.

**B. Purpose**

1. The purpose of this regulation as authorized by the OWTS Act is to establish minimum standards for the location, design, construction, performance, installation, alteration and use of OWTS within the state of Colorado, and establish the minimum requirements for regulations adopted by local boards of health including but not limited to permit application requirements; requirements for issuing permits; the inspection, testing, and supervision of installed systems; the maintenance and cleaning of systems; the disposal of waste material and the issuance of cease and desist orders.

**C. Effluent Discharged to Surface Waters**

## Ch 25 Public Notice Comments for 6-14-13 WWAB Meeting 155

Type of Soil Treatment Area	Method of Effluent Application from Treatment Unit Preceding Soil Treatment Area		
	Gravity	Dosed (Siphon or Pump)	Pressure Dosed
Trench	1.0	0.9	0.8
Bed	1.2	1.1	1.0

**Table 10-3 Size Adjustment Factors for Types of Distribution Media in Soil Treatment Areas Accepting Treatment Level 1 Effluent**

Type of Soil Treatment Area	Type of Storage/Distribution Media Used in Soil Treatment Area		
	Rock or Tire Chips	Manufactured Media Other Than Chambers	Chambers
Trench or Bed	1.0	0.9	0.7

**E. Design of Distribution Systems**

**1. General**

- a. The infiltrative surface and distribution lines must be level.
- b. The infiltrative surface must be no deeper than 4four feet unless adequate treatment at a deeper level can be demonstrated, and is approved by the local public health agency. The depth will be measured on the downslope side of the trench or bed.
- c. Trenches must follow the ground surface contours so variations in infiltrative surface depth are minimized. Beds must be oriented along contours to the degree possible.
- d. Pipe for gravity distribution must be no less than 3three inches in diameter.
- e. A final cover of soil suitable for vegetation at least 40ten inches deep must be placed from the top of the geotextile or similar pervious material in a rock and pipe system, chamber, or manufactured media up to the final surface grade of the soil treatment area.
- f. Following construction, the ground surface must be graded to divert stormwater runoff or other outside water from the soil treatment area.

Attachment 6

Lentz Email August 8, 2012

**Lentz, Dave**

---

**From:** Lentz, Dave <dlentz@infiltratorsystems.net>  
**Sent:** Wednesday, August 08, 2012 11:23 AM  
**To:** James Brough  
**Cc:** Rich Cripe; Berquist, Eric; Seth Tourney  
**Subject:** RE: Drainfield Size Reductions for Chambered Systems  
**Attachments:** WY chamber fact sheet\_080712.pdf; NC Field Study\_research paper version.pdf; OR King & Hoover Small Flows.pdf; ME Longevity of Conventional Gravel and Reduced Area Chambers - Rock et al.pdf; WY liquid level summary\_080712.pdf

James,

Thank you for getting in touch in advance of your rulemaking process. I am especially pleased that we will have the opportunity to provide a comprehensive picture of the research and studies that have been undertaken with regard to chamber performance and sizing. In addition, I will be more than happy to provide you with any chamber regulatory approval information you are interested in obtaining (e.g., approval letters, regulations, etc.). For instance, I understand that Sara Heger indicated that chambers are not granted a sizing reduction in Minnesota. There are actually two manners of sizing chambers in Minnesota, and the method that was excluded from her communication allows a 40% reduction compared to the sizing of a stone and pipe trench. I can provide agency documents supporting any sizing you may be interested in, as I want to make sure you have a complete, rather than partial account of the regulatory framework for a particular jurisdiction.

I will call you to discuss chamber sizing and information needs you may have at this time, but before doing so, I thought it may be helpful to respond to some of your initial questions and provide information that you may not yet have on the performance of chamber technology. I have attached the following items for your review and possible future discussion:

- **Chamber technology fact sheet** – This summary document highlights key studies that have been undertaken to investigate chamber performance in the field, and also provides information on gravelless technology use in general.
- **North Carolina field performance study** – Conducted by the North Carolina Department of Environment and Natural Resources this is one of the largest onsite system studies in the world, examining the performance of 300 chamber systems compared to 300 gravel systems in the field. The study found that there was no statistically significant difference in chamber system performance as compared to that of stone and pipe at a 95% upper confidence level.
- **Oregon field performance study at a 40% reduction** – This third-party study by Dr. Larry King and Dr. Michael Hoover at North Carolina State University was published in the Fall 2002 edition of Small Flows Quarterly. The study examined the performance of over 400 chamber and conventional stone and pipe systems and found that there was no statistical difference in surficial failure rates between these two system types.
- **Maine longevity study at a 50% reduction** – This study by the University of Maine's Dr. Chet Rock examines the longevity of gravelless drainfields sized at 50% the length of stone and pipe systems through the use of historical repair records. The study considers systems between 20 and 30 years old, with 63 chamber and 341 gravel system evaluated. The records show that, at a 95% upper confidence level, gravelless systems at a 50% sizing reduction outperformed stone and pipe. This study also provides an analysis of Sara Christopherson's (Heger's) University of Minnesota study, where manipulation of the dataset and distal measurement of effluent ponding in stone trenches skewed conclusions on the performance of chambers as compared to stone and pipe systems.

There is additional information responding to your concerns below (scroll down to your email to me), with Infiltrator's response appearing in **dark red font**. While Infiltrator is confident is the current sizing of chambers in Wyoming, we are

willing to discuss a means of adjusting the state's chamber sizing to build additional safety factor into chamber system designs and lower the reduction from its current level of 50%.

In addition to our interest in working with you on the chamber portion of the rule, we are also interested in proposing revisions to the tank section that will allow for septic tanks with liquid levels of less than 48 inches. Infiltrator manufactures two lines of septic tanks that are on the state's "Type B" list. The use of a liquid level that is less than 48 inches is consistent with tank manufacturing policy in place in many other North American jurisdictions, demonstrating that there are a variety of acceptable liquid levels that yield a properly functioning septic tank (i.e., discharge of clarified effluent). Given the prevalence of tanks with less than 48 inches of liquid and the codification of this type of geometry across the United States, we think that adjusting the rule for this type of design is a reasonable change. I have attached a summary of minimum liquid level requirements for numerous states. If interested, I have a quantitative analysis comparing key operating parameters for tanks with 48- and 40-inch liquid levels.

I look forward to discussing your concerns and the attached information by telephone.

Sincerely,  
Dave Lentz



**David Lentz, P.E.**  
*Regulatory Director*  
p. 860-577-7198  
f. 860-577-7793  
m. 860-575-8099  
[dlentz@infiltratorsystems.net](mailto:dlentz@infiltratorsystems.net)  
[www.infiltratorsystems.com](http://www.infiltratorsystems.com)

**From:** James Brough [<mailto:james.brough@wyo.gov>]  
**Sent:** Friday, July 27, 2012 11:41 AM  
**To:** Lentz, Dave  
**Cc:** Rich Cripe; Berquist, Eric; Seth Tourney  
**Subject:** Drainfield Size Reductions for Chambered Systems

Mr. David Lentz:

Eric Berquist contacted me yesterday concerning chambers and associated drainfield size reductions. Wyoming DEQ has had some internal discussion regarding this issue. Below is some discussion that I have shared with coworkers. If you have additional papers or insight, I would appreciate hearing back from you. Thanks.

Wyoming has a policy that grants a 50% reduction to the bottom of chambers due to elimination of a "masking" effect. Some states allow no footprint reductions for chambers. Sarah Heger with the University of Minnesota shared a report of a field study that compared rock-filled and chamber trenches. Basically the study failed to demonstrate an advantage of using chamber systems over rock-filled systems.

Please see the sixth page of the attached paper by Dr. Chet Rock for an analysis of the University of Minnesota study. The full dataset was not used to reach the conclusions in the paper, and measurement of ponding levels in trenches only at the distal end is believed to have led to inaccurate conclusions as effluent was dammed inside the trench, causing an accumulation at the proximal end while the distal end had no ponding. This phenomena has been documented in an unrelated study at the Massachusetts Alternative Septic System Test Center (MASSTC) in Buzzards Bay, MA.

**Field Comparison of Rock-Filled and Chambered Trench Systems**

[http://septic.umn.edu/prod/groups/cfans/@pub/@cfans/@ostp/documents/asset/cfans\\_asset\\_125871.pdf](http://septic.umn.edu/prod/groups/cfans/@pub/@cfans/@ostp/documents/asset/cfans_asset_125871.pdf)

Another paper from Colorado School of Mines has the following discussion. This paper indicates that 33 to 50 percent reduction could be granted to chambers in sand and sandy loam soils.

This sizing is consistent with sizing in many jurisdictions and is supported by other research. Please see the multiplier summary (Table 2) in the attached chamber fact sheet. For reference, a 33% reduction is a 1.5 multiplier, and a 50% reduction is a 2.0 multiplier.

**Wastewater Infiltration into Soil and the Effects of Infiltrative Surface Architecture**

[http://www.infiltratorsystems.com/pdfs/SFQ\\_w04\\_JURIED.pdf](http://www.infiltratorsystems.com/pdfs/SFQ_w04_JURIED.pdf)

Both of the States Idaho and Montana grant a 25% reduction for chambers in trenches. Utah grants 30% reductions for chambers in trenches. In short, I had one field study report that didn't support a reduction in drain field size when using chambers and another that supported a 33 to 50 percent reduction in sands. Per discussions with other state regulators, I came to the conclusion that Wyoming was giving the chambers too much credit for elimination of a "masking" effect.

The 50% reduction is not necessarily too much credit, as this sizing is consistent with research and has been proven to work over the long term (see attached University of Maine longevity study and consider Infiltrator's chamber performance track record in Wyoming). While Infiltrator is confident is the current sizing of chambers, we are willing to discuss a means of adjusting the state's chamber sizing to build additional safety factor into chamber systems and lower the reduction from its current level of 50%.

--

James S. Brough, P.E.  
Northwest District Engineer  
Water Quality Division

510 Meadowview Drive  
Lander, WY 82520  
[307-335-6961](tel:307-335-6961) (office)  
[307-332-7726](tel:307-332-7726) (fax)  
[james.brough@wyo.gov](mailto:james.brough@wyo.gov)

E-Mail to and from me, in connection with the transaction of public business, is subject to the Wyoming Public Records Act and may be disclosed to third parties.

Attachment 7

IAPMO Z1000-2013 Excerpts



IAPMO Z1000-20yy

# Prefabricated Septic Tanks



- (b) extend below the liquid surface between 50% and 75% of the liquid depth, measured from the inside floor of the septic tank; and
- (c) extend at least 120 mm (5 in) above the liquid surface.

#### 4.5.3

The invert of the inlet pipe shall be at least 50 mm (2 in) above the invert of the outlet pipe.

### 4.6 Venting

#### 4.6.1

Partitions, baffles, and inlet and outlet devices shall have a venting area not smaller than the cross-sectional area of the inlet or the outlet, whichever is greater.

#### 4.6.2

There shall be a separation of at least 25 mm (1 in) between the top of the tank and the top of the inlet and outlet device vent opening.

### 4.7 Partitions and Baffles

#### 4.7.1

Partitions and baffles separate compartments and shall extend at least 120 mm (5 in) above the liquid surface.

#### 4.7.2

Flow between compartments shall be through a

- (a) horizontal slot having a vertical dimension of at least 50 mm (2 in);
- (b) inverted tee, 90° elbow, or similar fitting at least NPS-4 but in no case smaller than the tank inlet; or
- (c) two or more equally spaced openings having a combined cross-sectional area of at least two times the area of the inlet device.

#### 4.7.3

The fitting inlets or the centroid of the openings shall be located between 50% and 75% of the liquid depth, measured from the inside floor of the tank.

### 4.8 Air Space

Septic tanks shall have at least 230 mm (9 in) of air space above the liquid surface. The air space shall have a volume equivalent to at least 10% of the working liquid volume of the tank.

### 4.9 Risers

When applicable, septic tanks shall have a means of connecting with an access opening extension system (i.e., risers) that is watertight.

### 4.10 Covers

Openings shall be capable of accommodating covers (i.e., lids) that

- (a) are watertight;
- (b) are secure;

**Note:** Acceptable measures for securing covers include padlock(s), covers that can be removed only with tools, or covers with a mass of at least 30 kg (66 lb).

Attachment 8

IAPMO Z100-2007 Excerpts

# IAPMO/ANSI Z1000-2007

# Prefabricated Septic Tanks



ANSI Accredited Program  
PRODUCT CERTIFICATION

AN AMERICAN NATIONAL STANDARD



For IAPMO Main Standards Committee Member Use Only. Distribution Prohibited.

IAPMO/ANSI Z1000-2007

maintenance holes with a minimum 20 in. (50 cm) inside dimension. One access maintenance hole shall be located over the inlet, and one access maintenance hole shall be located over the outlet.

**3.4** The inlet and outlet pipe or baffle shall extend a minimum of 5 in. (12 cm) above and a minimum of 8 in. (20 cm) below the water surface. The invert of the inlet pipe shall be at a level not less than a minimum of 3 in. (8 cm) above the invert of the outlet pipe.

**3.4.1** The inlet sanitary tee shall not be smaller in size than the connecting sewer pipe nor less than 4 in. (10 cm). The outlet sanitary tee shall not be smaller in size than the connecting service pipe.

**3.5** Compartment partitions and inlet and outlet fittings or baffles shall have a free-vent area greater than or equal to the cross-sectional area of the larger of a nominal pipe size 3 in. pipe or the inlet pipe. Free ventilation shall be provided above the water surface from the disposal field or seepage pit through the septic tank, building drain and vent stack to the outside air.

**3.5.1** Partitions or baffles shall be constructed between compartments and shall extend at least 5 in. (12 cm) above the liquid level. Flow from inlet to outlet compartment shall be through a horizontal slot (having a minimum vertical dimension of 2 in.), a tee, ninety (90°) degree elbow or similar fitting (equivalent in size to the tank inlet but not less than 4 inches (10 cm) in diameter), inverted and extending down into the inlet compartment so that the entry to the fitting is located midway in the liquid depth of the tank.

**3.5.2** Septic tanks shall have an air space equal to not less than 10 percent of the liquid volume, and total depth shall not be less than 9 in. (23 cm) above the liquid level. There shall be a minimum of 2 in. (5 cm) of separation between the top of the tank and the top of the sanitary tee vent opening.

**3.6** Exterior walls shall be designed for a minimum inside hydrostatic water pressure equal to the head pressure based upon the height of the outlet. The exterior walls shall also be designed to withstand a minimum outside earth pressure equivalent to that exerted by a fluid with a density of 30 lbs/ft<sup>3</sup> (481 kg/m<sup>3</sup>).

**3.6.1** Internal baffles and fittings shall be designed to withstand the combined hydraulic and earth loads occurring when any compartment is empty of fluid and the remaining compartment(s) is full.

**3.7** Septic tanks and covers shall be designed for a vertical earth load of not less than five hundred (500) lbs/ft<sup>2</sup> (24 kPa) when the maximum coverage does not exceed 3 ft. (0.9 m). Regardless of coverage, each tank and cover shall be structurally designed to withstand all anticipated earth or other loads.

**3.7.1** Prefabricated septic tanks for installation in traffic areas shall be designed in accordance with ASTM C 890 for A-16 vehicle loading (AASHTO HS20-44). Wheel loading, dead load, horizontal pressures, and load surcharge shall be applied based on the requirements of ASTM C 890.

**3.7.2** Septic tanks shall be designed to accept an access riser which can be brought to grade. Access riser(s) shall have a leak-resistant closure (i.e., lid) that cannot slide, rotate, or flip, thereby exposing the opening. The lid shall be designed to support the anticipated live load. The opening shall be designed to prevent the access of un-authorized individuals.

**3.8** Connections between pipes and precast concrete tanks shall utilize flexible connectors which conform to ASTM C 1644. Connectors used between pipes and tanks made of materials other than precast concrete shall demonstrate conformance with the performance requirements of ASTM C 1644, paragraph 7.

**3.9** Prefabricated Septic Tanks consisting of two or more sections shall have joints designed such that uniform pressure is exerted on joint sealants or gaskets along their entire length and shall provide a continuous watertight seal. The joint material shall be supplied by the manufacturer and shall be applied at the time of installation per manufacturer's requirements, unless otherwise approved by the Administrative Authority. Any tank with a horizontal joint below the liquid level shall be permanently bonded or mechanically fixed.

**3.9.1** Gaskets, when required, used to seal horizontal seams in tanks shall be permanently fixed so they do not separate when subject to periodic servicing, seasonal shrink/swell pressures, or non-uniform differential settlement.

## 4. Material requirements

### 4.1 Concrete.

**4.1.1** Concrete septic tanks shall comply with the "Materials and Manufacture" section of ASTM C 1227 and shall have a minimum compressive strength of 4000 psi (28 MPa) at 28 days of age and a maximum water to cementitious ratio (w/c) of 0.45.

**4.1.2 Sealants.** Flexible sealants employed in the manufacture or installation of tanks shall conform to ASTM C 990. Rigid (mortar) sealing or grout sealant of tank sections shall not be permitted.

**4.1.3 Lifting.** Lifting devices, embedded or otherwise attached to the tank, shall comply with the requirements of ASTM C 890.

**4.1.4 Synthetic fiber-reinforced concrete tanks.** Polypropylene or polyolefin fibers are only permitted as a

Attachment 9

Tank Airspace Volume Analysis by State

Infiltrator Systems Inc.  
 Summary of Septic Tank Air Space Volume to Working Volume Regulatory Requirements

State/Standard	Minimum Air Space as a Function of Working Volume (%)
IAPMO/ANSI Z1000	10
CSA B66-05	10
AL	No requirement
AR	12.5
AZ	No requirement
CA	Varies by county regulation
CO	No requirement
CT	No requirement
DE	No requirement
FL	15
GA	No requirement
IA	No requirement
ID	15
IL	No requirement
IN	No requirement
KS	No requirement
KY	No requirement
LA	No requirement
MA	No requirement
MD	No requirement
ME	No requirement
MI	No requirement
MN	15
MO	15
MT	20
NC	No requirement
NE	No requirement
NH	No requirement
NJ	No requirement
ND	20
NM	No requirement
NV	No requirement
NY	No requirement
OH	No requirement
OK	No requirement
OR	10
PA	No requirement
SC	No requirement
SD	20
TN	No requirement
TX	No requirement
VA	No requirement
WA	10
WI	No requirement
WV	No requirement
WY	20





## Fwd: Chapter 25 comments

1 message

**William Tillman** <william.tillman@wyo.gov>

Tue, May 28, 2013 at 6:55 AM

To: Gina Johnson <gina.johnson@wyo.gov>, Frank Strong <frank.strong@wyo.gov>

----- Forwarded message -----

From: **John Woodward** <jwoodward@lcwy.org>

Date: Mon, May 27, 2013 at 9:46 PM

Subject: Chapter 25 comments

To: [william.tillman@wyo.gov](mailto:william.tillman@wyo.gov)

Dear Mr. Tillman,

I would like to submit three comments regarding the proposed regulation changes:

1. On the first page under Section 2 Objectives the proposal states that all advanced treatment septic systems shall be designed by Wyo. P.E. and permitted through DEQ. This changes the policy that has been in effect since 1984. Under the current regulation if the advanced treatment system design is certified according to NSF Standard 40 then it is considered a basic design, or at least it may be so by the delegated authority. Given the fact that our jurisdiction has 70 of these NSF 40 systems installed and over 400 vacant subdivision lots that require such it appears that a stroke of the pen has added \$1,000.00 to \$3,000.00 to the cost of developing these and future lots. It is odd that the final draft is the only time in this lengthy process that this change suddenly appeared. Is my county being singled out for some reason? Especially given that so many rather complex systems are not required to have the P.E. design. I refer to the provisions for Gray Water Systems, Grease Interceptors, Car Washes, Sand Mounds, Lagoons and Pressure Distribution Systems.
2. On page 25-14, Section 6, Paragraph g. it appears that public water wells are now to be arbitrarily protected by a 300 feet buffer from the nearest septic tank and by a 600 feet buffer from the nearest drain field. Again, where was this extreme idea two years ago when the process started? I trust that your agency performed the checklist required in W.S. 9-5-301 regarding regulatory takings because you have, with a stroke of the pen, added thousands of dollars of cost to anyone wanting to build on their property within this most arbitrary five acre buffer zone. There is an exception in that statute for health and safety issues but a property owner who is clearly down gradient will now have to spend thousands to prove the obvious.
  - o Given that septic tanks are to be water tight, how does 300 feet work better than 50 feet for a setback?
  - o Heretofore the burden of creating a wellhead protection zone lies with the well owner. If that well owner wants to stop development within 300 feet then that owner can purchase that property, purchase an easement, or in the case of a government entity, condemn the property through due process.
  - o The new regulation places the burden of hydraulic analysis on the property owner who is guilty of nothing but owning property near a public well.
  - o Here in Star Valley we encourage community water systems so that there are not too many individual water wells. We have over 20 systems that are public systems. Some have a 200 feet protection area if they were part of a subdivision that underwent a Chapter 23 review but most only have a 100 feet buffer.
  - o 20 X 5 = 100 acres of new buffer zones where legal lots of half acre up to two acres in size have just been rendered unbuildable until an affected property owner pays thousands of dollars for a hydraulic analysis. Is this not the definition of a regulatory takings?
3. I see in the stakeholder comments that there is still consideration being given to prohibiting septic systems in an identified floodplain. I hope that this does not happen. Please consider the fact that floodplain maps vary greatly in their accuracy and they are only insurance probability exercises. The title FIRM stands for Flood Insurance Rate Map. This means that they are geographic depictions of probability. In areas where there is sufficient population and political pressure the map resolution is good. In rural areas, such as Lincoln County, the map quality ranges from fair to poor. Some of our county's maps date back to 1981 and appear to be based on aerial photography of lands that were flood irrigated at the time. Even with decent maps the NFIP, National Flood Insurance Program, is quick to point out that 30% of the claims that they pay out are for those policies purchased by folks outside the official floodplain boundary. Flood resistant designs can usually protect rivers and streams. I urge you not to arbitrarily disallow septic systems in floodplains. Again it would seem to be a regulatory taking to do so.

Sincerely,

John Woodward  
 Director  
 Lincoln County Planning and Engineering



--

William Tillman, P. E.  
Water and Wastewater Section  
Regulatory and Enforcement  
Herschler Building, 4-W  
122 West 25th Street  
Cheyenne, WY 82002  
(307) 777-6941  
(307) 777-6779 (FAX)  
[william.tillman@wyo.gov](mailto:william.tillman@wyo.gov)

"Live like there's no tomorrow. One day you'll be right"

E-Mail to and from me, in connection with the transaction of public business, is subject to the Wyoming Public Records Act and may be disclosed to third parties.



---

## Fwd: Written Comments on Draft Chapter 25

1 message

---

**William Tillman** <william.tillman@wyo.gov>

Tue, May 28, 2013 at 6:51 AM

To: Gina Johnson <gina.johnson@wyo.gov>, Frank Strong <frank.strong@wyo.gov>

----- Forwarded message -----

From: **Jim Stevenson** <jim@rockvalesystems.com>

Date: Sun, May 26, 2013 at 10:37 PM

Subject: Written Comments on Draft Chapter 25

To: [william.tillman@wyo.gov](mailto:william.tillman@wyo.gov)

Cc: Sean McGuigan <msmcguigan@gmail.com>, lee rashkin <lwrashkin@gmail.com>, ken Adams <ken@rockvalesystems.com>, [lldurant@winnelson.com](mailto:lldurant@winnelson.com), [DWinkelman@winnelson.com](mailto:DWinkelman@winnelson.com), [jtgillespie@winnelson.com](mailto:jtgillespie@winnelson.com)

Mr. Tillman,

Please accept the attached from RockVale Systems. RockVale is the Wyoming distributor of Presby AES drainfield technology and Nibbler high strength wastewater treatment systems.

Thank you for the opportunity to comment on this important statute.

Jim

James A. Stevenson

**RockVale Systems, LLC**

81 River Road

Silesia, Montana 59041

[www.rockvalesystems.com](http://www.rockvalesystems.com)

ph: 406.861.2683

[jim@rockvalesystems.com](mailto:jim@rockvalesystems.com)

--

William Tillman, P. E.

Water and Wastewater Section

Regulatory and Enforcement

Herschler Building, 4-W

122 West 25th Street

Cheyenne, WY 82002

(307) 777-6941

(307) 777-6779 (FAX)

[william.tillman@wyo.gov](mailto:william.tillman@wyo.gov)

"Live like there's no tomorrow. One day you'll be right"

E-Mail to and from me, in connection with the transaction of public business, is subject to the Wyoming Public Records Act and may be disclosed to third parties.

---

### 2 attachments

**Missoula Alternative Systems Manual 2012.pdf**  
275K

**RockVale WY Chapter 25 Comments, 25May13.pdf**  
262K



## Comments on Proposed New Chapter 25 Small Wastewater Systems

May 25, 2013

Jim Stevenson, RockVale Systems, LLC

[jstevenson@dishmail.net](mailto:jstevenson@dishmail.net) 406-861-2683

- A) Section 2, Paragraph 2: Consider revising the 60 mpi limit to 90 mpi. Contractor soil percolation tests and soil absorption system designs are reliable up to 90 mpi and setting the limit at 60 mpi could be overly restrictive considering the range of soil types found in Wyoming.
- B) Section 2, Paragraph 2:
- a. PE certification of small wastewater systems that incorporate advanced treatment technology should not be required for non-mechanical (passive) systems that are installed in hydrologically simple settings. No technical justification would appear to exist to require PE certification of each Presby AES small system drainfield while not requiring it of chamber drainfields. In both 2011 and 2013, RockVale provided WDEQ significant justification and completed numerous successful installations in Wyoming within the past two years without PE certification, as well as many thousands nationwide, to show this requirement is unnecessary for non-mechanical systems meeting NSF 40 Class 1 standards.
  - b. Both chambers and pipe/stone systems are considered disposal-based technologies rather than treatment-based technologies. Even so, pipe/stone has been shown to provide a roughly 30% reduction of septic tank effluent BOD5 and TSS. However the application of untreated effluent directly to the soil via chambers provides no treatment and therefore relegates the technology to a strictly disposal definition. By adopting into statute within Chapter 25 chamber technology in a direct soil application mode, WDEQ could present the appearance of favoring a technology that is even more threatening to groundwater quality than historic pipe/stone technology. Since basic chambers technology applies untreated STE directly to the soil, it presents both a greater threat to groundwater quality and a relatively high drainfield failure rate due to soil pore clogging. From this perspective, of the two technologies adopted into statute within Chapter 25, chambers would appear to be the least protective of groundwater quality. Due to a relatively high failure rate and applying raw STE to the absorptive surface, WDEQ could justify mandating both PE certification and site-specific hydrogeologic studies of any small wastewater system desiring to use chamber technology. WDEQ could as well consider gradually phasing out the direct soil application mode of chambers and/or limit the conditions of its application. Simultaneously WDEQ could demonstrate that it is in fact actively adopting passive aerobic technologies proven to meet or exceed NSF 40 Class 1 standards while being more protective and reliable than chambers.
  - c. If enacted, it would appear likely the only small systems exempt from PE certification within Chapter 25 would be those employing chambers or pipe and stone technology. The requirement for PE certification is often viewed by small system owners as an extra cost and time expense and therefore the requirement for certification by a class of

system while no PE certification is required of chambers and pipe/stone, could be viewed as giving chambers an unfair market advantage over other technologies.

- C) Section 3 (a): Consider restricting the definition of “absorption surface” to mean only native soil, as otherwise it could potentially create confusion throughout this chapter and with others. The word “fill” is undefined and confusion could arise where sand, gravel or other engineered media are used in a mounds, beds or trenches.
- D) Section 3 (b):
- a. The separate definitions of Chapter 25 “advanced treatment” and Chapter 23 “enhanced treatment” could result in significant confusion on the part of regulators, counties, engineers, contractors and residents.
  - b. The threshold limit of 100 mg/l BOD5 as defining “advanced treatment” would appear to be a high numerical value relative to EPA secondary standards and to virtually all other states that have set such treatment standards. Specifying a TSS limit would also appear to be important, if not required, since soil pore clogging by fine solids is known to be the initial cause of drainfield failure. BOD5 alone has not been shown to be as causative of drainfield failure as suspended solids. The existing requirement for septic tank effluent filters is WDEQ acknowledgement of the foregoing. Alternative to the 100 mg/l specification, WDEQ could consider defining advanced treatment as meeting or exceeding NSF 40 Class 1 standards which is widely recognized and a standard in which a TSS limit is included. To that end, most all effluent treatment technology manufacturers applicable to small systems achieve NSF 40 Class 1 standards, while even relatively crude treatment technologies can achieve <100 mg/l BOD5.
  - c. It is understood that typical mechanical NSF 40 Class 1 technologies when operated out of specification have the potential to emit 100 mg/l or greater BOD5 wastewater and therefore additional professional oversight and management is typically afforded mechanical systems. However of similar concern is that a significant number of small systems exhibit <100 mg/l BOD5 at the outlet of a standard septic tank and/or standard lift station (virtually none exhibit NSF 40 Class 1 at the outlet). In setting 100 mg/l as the “advanced treatment” standard, will WDEQ be requiring PE certification of certain standard systems since septic tanks and lift stations (passive treatment devices) have the potential to discharge less than the 100 mg/l standard? Similarly, placing a simple mechanical bubbler in a small system septic tank can yield STE lower than 100 mg/l BOD5. Such simple mechanical devices are clearly not “advanced systems” that would warrant PE certification simply due to being capable of achieving <100 mg/l. Clearly, as is typical in Chapter 23 and in statutes of other states, the background quality and use of the groundwater at each site should define the need for “advanced treatment”, while the system type (private or public) and discharge volume (exceeding 2,000 gpd) should dictate PE certification. As a potential resolution, WDEQ could differentiate between mechanical treatment which is prone to high rates of mechanical failure and passive treatment technologies which generally exhibit much lower failure rates. Septic tanks are an example of a passive primary treatment or “pretreatment” device.
  - d. It is well-proven, well-documented that regulators are appropriately safe and justified to grant soil loading area reductions and/or vertical separation reductions to treatment-based technologies that meet or exceed NSF 40 Class 1. Therefore it could be claimed by some that WDEQ is proposing to adopt a unique 100 mg/l BOD5 limit as the definition of “advanced treatment” with the express intent of disallowing the granting of these reductions to the relatively high number of NSF 40 Class 1 technology providers. In this way WDEQ could then claim it is being protective of groundwater by

not granting soil loading area and vertical separation reductions to “advanced treatment” technologies which discharge a 100 mg/l BOD5 effluent . It could be claimed that by effectively disallowing soil loading area and vertical separation reductions for the entire class of NSF 40 Class 1 technologies, that WDEQ has constructed a highly subtle and unique regulatory barrier that ensures no technology will have a technical advantage over chambers. As a means to avoid even the remote appearance of the foregoing, and in the interest of completeness and consistency with the rest of the nation, NSF 40 Class 1 should be set as Wyoming’s advanced treatment standard.

- e. When the 100 mg/l BOD5 threshold definition of “advanced treatment” is considered in combination with the Section 2 requirement that PE certification is required of all “advanced treatment” systems, it could be interpreted as WDEQ once again ensuring that virtually any treatment process will be disadvantaged relative to chambers and pipe/stone in regard to application to small systems. If WDEQ took the foregoing into consideration when proposing Section 3 (b) in combination with Section 2, then prior to finalizing Chapter 25 WDEQ should likely make publically available its notes, technical references and supporting information indicating its rationale for proposing the relatively unique 100 mg/l threshold.
  - f. As part of the Section 3 (b) definition, WDEQ could consider proactively stating within Chapter 25 that systems achieving NSF 40 Class 1 should be provided a soil loading area reduction relative to traditional pipe and stone systems. The rationale for these reductions is supported by numerous investigators, the EPA and numerous states such as Washington, Minnesota, Montana and others. Granting area and vertical separation reductions for NSF 40 Class 1 technologies would signal that WDEQ is acknowledging that many Wyoming land owners are confronted with SHGW and/or space constraints and are seeking safe and economical solutions.
- E) Section 3 (c): Consider deleting the word “soil” in view of soil being undefined and potential confusion arising where sand (ASTM C-33), gravel (2”) or other engineered media are used in trenches, beds and mounds to effect treatment.
- F) Section 3 (i): By including only chambers in Section 3, it could be interpreted that WDEQ favors one proprietary technology over others. To avoid this, consider also defining in Section 3 drip systems, pipe and stone and passive aerobic treatment system (Presby AES) within Section 3. The rationale for listing passive aerobic treatment as a recognized drainfield technology is that it competes directly with chambers, has been applied for over 15 years and 250,000 installations in the US and Canada with less than 0.5% failure rate, has been approved in a majority of US states, all Canadian provinces as well as a number of European countries, carries BNQ, NSF 40 Class 1 and CE certifications. Additionally, Presby AES has a sound track record of installation within Wyoming under close WDEQ scrutiny via Policy 13.41.08. For sample language to include passive aerobic treatment in Chapter 25, please see attached Missoula Alternative Systems Manual - Chapter 17. By adopting not only chambers into statute but passive aerobic treatment and drip systems as well, Chapter 25 would be less partial to a single technology. As opposed recognizing only one proprietary technology in Chapter 25, WDEQ and Wyoming residents would likely benefit from recognizing at least two competitive proprietary technologies.
- G) Section 3 (v):
- a. Consider specifying as to whether the 200 mg/l BOD5 limit is measured at the inlet or outlet of the primary or pretreatment device (septic tank or lift station for small systems) and define whether it is the allowable peak or a geometric mean of 30 days, or other.

- b. If the 200 mg/l definition of HSW is based on the septic tank outlet, then it would appear to be a reasonable value to select relative to most state definitions of small system HSW, which range from 150 to 300 mg/l at the septic tank outlet. However WDEQ should consider as well specifying both TSS and Fat, Oil & Grease (FOG) limits on the septic tank outlet. Sound references exist on TSS and FOG ranges for small systems.
- c. If the 200 mg/l definition of HSW is at the septic tank inlet, then based on the the following comments it may be an unreasonably low value, as well as difficult to sample and measure accurately, and potentially in conflict with both the definition of both “advanced treatment” and “pretreatment”.
  - i. It is well documented and largely recognized that small system septic tanks with effluent filter provide a 30% to 50% reduction in both BOD5 and TSS. Similarly, typical small system STE exhibits average outlet BOD5 concentrations ranging from 125 to 175 mg/l and TSS concentrations ranging similarly. Therefore working backward, typical small septic tank inlet BOD5 concentrations can easily exceed 200 mg/l when homes are equipped with modern water conservation fixtures and appliances. This fact in combination with a lack of HSW definition, could render the HSW regulation irrelevant or unenforceable. Alternatively, it could cause residents to dilute their wastewater to avoid regulation or require WDEQ to expand its enforcement division in order to sample and cite a large number of small system dischargers in violation. Sampling and measuring small system septic tank influent BOD5 concentrations is difficult due to the pronounced concentration of BOD5 into the solid fraction. This and a lack of HSW definition could make this regulation challenging to enforce.
  - ii. Working forward, if WDEQ research found that most all small system septic tank influent is safely under 200 mg/l BOD5 HSW limit, then upon undergoing a 30% 50% reduction within the septic tank, likely a very large number of small system septic tanks with effluent filters would be classified as “advanced treatment” devices, based on discharging <100 mg/l BOD5 effluent to the absorptive surface via a chamber drainfield. In aggregate, the very real potential exists that through operating a standard septic tank at low flow, a small system owner could be cited by WDEQ for both exceeding the HSW limit while simultaneously operating an “advanced treatment” unit that not certified by a PE. It would appear that a least some potential for conflict exists among key Chapter 25 definitions however that may be based on a lack of this reviewer’s understanding of WDEQ rationale.
  - iii. Based on the foregoing, the questions could be asked: Did WDEQ write an internal position paper considering the combined effects of setting the 200 mg/l HSW limit and the 100 mg/l advanced treatment limit and as well requiring PE certification of all treatment based technologies? Did WDEQ actively research and assess the combined effect of setting a 200 mg/l HSW limit while simultaneously decreasing the per bedroom residential design flow? If in fact small system septic tanks have an influent BOD5 relatively close to 200 mg/l, then Chapter 25 presents the potential for numerous small systems to be designed by non-engineers and then be violation of the HSW limit. Therefore many non-engineers could be cited for designing systems that threaten groundwater quality and public health without PE certification. In all, before

finalizing Chapter 25, WDEQ may desire to make publically available its internal written rationale on how these key definitions work in consort.

- H) Section 3 (dd): Since uniform linear distribution is the goal of a properly designed pressure distribution system, the term “Uniform Distribution” should be used throughout the Chapter while “Pressure Distribution” could be defined as one of several methods of achieving uniform distribution. As examples, Presby AES achieves uniform distribution via gravity while drip systems present yet another form of pressure distribution. By inferring within the statute that only one form of uniform distribution exists and that form almost exclusively incorporates chamber technology, it could be construed that WDEQ favors one proprietary technology over others. Presby AES can be used in pressure distribution mode though achieves uniform distribution via gravity. Presby AES in serial gravity arrangement provides a sound, more reliable and lower first cost alternative to pressure distribution - attributes typically important to small system owners.
- I) Section 3 (ee): Consider replacing the word “pretreatment” with “primary treatment”. The rationale is that primary treatment is a recognized term in the wastewater treatment industry and commonly defined as solids separation, which in small systems is provided by a septic tank. Secondary treatment is commonly defined as BOD reduction to 30/30 standards while tertiary treatment typically means better than 10/10. In general, the term “pretreatment” is not succinctly defined within the wastewater treatment industry. The typical progression of treatment is primary treatment, followed by secondary treatment, followed by tertiary treatment. Understanding that “advanced treatment” is now defined within Chapter 25, it seems logical to use the term “primary treatment” rather than “pretreatment”.
- J) Section 3 (hh): Since a septic tank meets the definition of “Pretreatment” of Section 3 (ee), and septic tanks are universally required in small systems, consider referencing septic tanks as an example of either “pretreatment” or “primary treatment”. Such an example would decrease the vagueness of the current definition.
- K) Section 3 (ii): As noted above, consider the potential confusion caused by Wyoming statutes containing both “advanced treatment” and “enhanced treatment”.
- L) Section 3 (jj): Consider replacing the word “pretreated” with “primary treated”.
- M) Section 5:
- a. The first subsections of Section 5 would appear to present the opportunity for WDEQ to clearly define and formalize either: a) how candidate new technologies can first be granted an Administrative Policy and then take the same Policy-to-Statute pathway as demonstrated by chambers, or b) how, similar to Idaho, Minnesota and other states, candidate new technologies are reviewed and approved, along with specification of the composition of a voluntary technology review board. Further, within Section 5 it could be stated that approvals from recognized national/international certifying entities may be accepted as well as qualifying third-party test data from other jurisdictions. For example, Presby AES and drip systems are well proven technologies and the anticipation might be that they too will soon take the same Policy-to-Statute pathway as has been provided chambers. Rather than broad adoption of chambers into Chapter 25, the regulatory criteria and process for technology review and approval should likely be well documented for all parties to follow.
  - b. As currently drafted, Section 5 could require WDEQ to review and administer a large array of ongoing pilot tests under relatively uncontrolled conditions. This would be expensive and potentially subject to challenge if it is not fully funded for implementation. Unfortunately, the veracity of results from such expensive field pilot studies could be legally challenged by Infiltrators, other manufacturers or special

interest groups. Forcing all candidate new technologies to conduct expensive field pilot tests in Wyoming with the results potentially subject to litigation by special interests presents a massive barrier to entry. In this fashion, Section 5 as drafted could be viewed as effectively ensuring that a single chamber manufacturer could exercise uncontested pricing power in the state.

- c. Similar to chamber technology, the only current avenue by which Presby and other technologies can gain entry to the Wyoming market is via DEQ Administrative Policy. In the interest of fairness, WDEQ may be justified in not providing chamber technology such a broad statutory superiority to others by more effectively holding chambers at the Administrative Policy level.
- d. In specific regard to chambers, only one major US chamber manufacturer exists today, Infiltrators. When DEQ Policy 13.41.08 was crafted, 3 to 5 chamber manufacturers existed and therefore no advantage was being provided to any single company. However in 2005 it was estimated that Infiltrators controlled 80% of the world chamber market and upon buy-out of ADS's chamber division in 2011, Infiltrators now holds very close to 100% of the US chamber market. Therefore, a potential exists for the current Chapter 25 draft to be viewed as providing one manufacturer a significant statutory advantage over all other technology providers. Such a dominant player as Infiltrators likely does not need a statutory advantage over all other proprietary technologies. Of potential concern to Wyoming small system owners might be that with only one manufacturer controlling 100% of the Wyoming drainfield market, that manufacturer could increase its product prices to where residents would have only pipe/stone technology as an alternative. The question could be asked whether or not Wyoming residents are benefited by and protected from the adoption of only one proprietary technology into statute. If WDEQ due diligence includes research of chamber technology and Infiltrators' related market share, it may desire to make that document publically available before finalizing Chapter 25.
- e. Corollary to the foregoing, WDEQ has in fact been working to bring viable market choices to residents and businesses, as evidenced by its recent crafting of DEQ Policy 13.41.08 for Presby AES. We firmly believe that WDEQ should maintain that same thorough, open, impartiality to new technologies in Chapter 25. WDEQ could therefore focus Chapter 25 on ensuring that Wyoming residents are afforded consistent ongoing access to viable, well-proven and up-to-date technologies.
- f. While Presby AES has been deployed within the context of a DEQ Administrative Policy, we can see how over the long term a multitude of policies could become administratively cumbersome. As an example, as a new entrant into Wyoming, RockVale had no single integrated source document to assist in understanding the various DEQ Policies in effect, how to go about gaining one and our statutory rights as applicants and eventual recipients. Two years later, RockVale still does not fully understand the Administrative Policy system, in view of DEQ Policy 13.41.08 recently being called under WDEQ technical scrutiny prior to its typical five year schedule. Of potential concern to WDEQ might be that the department could be viewed as calling for an unscheduled review and questioning of the only DEQ policy providing competition to chamber technology while simultaneously making revisions to Chapter 25 that appear to specifically favor chamber technology.
- g. As an alternative to what would appear to be a potentially disparate DEQ Administrative Policy system, Wyoming might best be served by combining all current and future Administrative Policies into a single technology-related document (Guidance or Circular,



etc) that is reviewed and updated on a regular basis so as to maintain step with technology. Since chamber technology would be contained in this compendium of Policies, chambers would remain on an equal regulatory status with all other proprietary technologies. This would also enable Chapter 25 to remain relatively free of technology- and practice-specific language.

- N) Section 6: WDEQ should proof this section closely to ensure that it is absolutely impartial with respect to disposal-based technology and that it is not simultaneously setting prohibitively high barriers for treatment-based technology.
- O) Section 6 (b): If significant surfacing and ponding of effluent is present, is it always feasible to excavate and install a new trench system only 3 ft away? Have system replacements been proven effective when new trenches are installed between failed trenches spaced at 9 ft?
- P) Section 6 (d):
- a. This provision may induce a significant amount of confusion and ambiguity in its application, monitoring and enforcement. Of importance, investigations have shown that both trench/bed spacing and overall drainfield layout have large impacts on groundwater mounding. As an example, either a long and narrow drainfield layout or a relatively wide trench/bed spacing will impart a much lower groundwater mound than a square drainfield layout and/or closely spaced trenches/beds. Based on the foregoing, if Section 6 (d) was developed based on modeling a drainfield as either a single point hydraulic load or a single linear hydraulic load while not considering the multitude of potential drainfield layouts, the graphs could be significantly in error. To be useful, the model and related graphs should be proven accurate for trench spacings from 3 ft to 9 ft and for chambers in parallel operation within the first two years of operation and at 5 year intervals thereafter. If Section 6 (d) is to be applied to bed systems, then similar spacing considerations should be taken into consideration for beds as well. If Section 6 (d) is not accurate over a significant portion of the foregoing range, then it may be expensive and difficult for WDEQ to apply and then attempt to monitor and enforce. Similar to other states publishing the full technical basis and bibliography for their rulemaking, WDEQ is encouraged to proactively make a copy of the technical basis for Section 6 (d) along with WDEQ internal written rationale for extrapolation to the potential range of trench and bed layouts.
  - b. In view of the complex provisions of Section 6 (d), the necessary gathering and interpretation of site-specific soil and groundwater data, interpretation of subtle influences of seasonality combined with drainfield layout, utilization and age, and finally application of Section 6 (d) graphics could, in total, be viewed as requiring not only a Wyoming PE in order to adequately design each small system. It could be argued that the complexity of this one provision requires Wyoming PE certification of all chamber and pipe/stone system designs. In this reviewer's estimation, likely less than 2% of all Wyoming residents have the technical ability to competently apply this provision, provided the myriad of drainfield layouts, types and site situations. If WDEQ has documentation of other states where non-professionals have applied this provision successfully for a number of years, it may desire to make those documents publically available prior to finalizing Chapter 25.
  - c. As an alternative to endeavoring to protect groundwater quality strictly through vertical separation from disposal-based technologies, in its adoption of Chapter 23 "enhanced treatment" and now Chapter 25 "advanced treatment", Wyoming (similar to most other states) appears to be moving toward treatment based standards. This is a reasonable and proven course, as demonstrated in Minnesota, Washington and elsewhere. In

these states, smaller vertical separation distances are allowed based on achieving higher levels of effluent treatment. However while Wyoming is proposing a somewhat unique 100 mg/l “advanced treatment” standard within Chapter 25 it is also adopting chambers into statute, a technology that provides no treatment. This could represent a large divergence in regulatory direction since many states, along with adopting treatment based standards, are allowing reduced vertical separation based on increased levels of treatment. It would appear however that WDEQ is moving the state in exactly the opposite direction by adopting only chambers into statute and further supporting it with Section 6(d) which is meant to ensure 4 ft of separation is maintained at all times. This could be construed as ensuring the future of highly basic, disposal-based technologies such as chambers and pipe/stone. Alternatively, if embracing treatment based standards is a long-term WDEQ goal, then Section 6 (d) could be eliminated along with a reduction of what would appear in Chapter 25 to be a singular preference for disposal based technology. As in a number of states, WDEQ could craft a provision stating that for technologies meeting NSF 40 Class 1 standards, WDEQ will grant a soil loading area reduction and/or a decreased vertical separation from occluding layer or SHGW, provided appropriate supporting technical data. By implementing DEQ 13.41.08 for Presby AES, WDEQ has already taken significant and what might be viewed as progressive steps away from a strict preference for disposal-based technology. Within Policy 13.41.08, WDEQ approved a 30” vertical separation from bottom of Presby AES pipe to SHGW as well as a 50% soil loading area reduction relative to pipe/stone technology. WDEQ policy was correctly based on the technology exceeding NSF 40 Class 1 standards and the submittal of a large amount of supporting technical data.

- d. Since many Wyoming residents are confronted with SHGW issues, if retained Section 6 (d) could become viewed negatively when companioned by a Chapter 25 with the appearance of bias toward a technology controlled by one company.
- Q) Section 7 (b): Referencing page 11 of the attached Washington Dept of Health study, we believe that no subsurface distribution structure (chambers, beds or pipe/stone) should be provided credit for sidewall loading area. The report and numerous references show that sidewall infiltrative area is utilized only when untreated effluent is standing stagnant throughout the length of the structure, which indicates that progressive anaerobic failure of the entire drainfield bottom area. Prior to complete failure of the bottom area and subsequent deep ponding of effluent throughout, little or none of the sidewall surface area is utilized. Therefore it has been shown that the only time that sidewall surface area is used for effluent infiltration is for a brief period immediately preceding complete anaerobic failure. The period that sidewall surface area is used is relatively brief because once the side vents are inundated, gas exchange to the chamber interior is then completely cut off. This leads to rapid anaerobic slime coating of the entire chamber interior. Based on study conclusions, no infiltrative area reduction credit should be given to sidewalls of chambers, beds or pipe/stone trenches. The only soil loading area reduction that has been fully justified by numerous studies, EPA and states is for systems that treat effluent to 30/30 standards or better before contact with the fine grained infiltrative surface. Further, any area reduction granted should be applied only to the bottom area of the bed, trench or mound. Therefore chambers should not be provided absorptive area credit for sidewall loading. As well, no soil loading area reduction should be given chambers based on the technology being incapable of treating to 30/30 or better.
- R) Section 7 (c): Since the terms “fine sand” and “loamy sand” are undefined in terms of particle size distribution or infiltration rate, consider rewording: “...backfilled with a medium sand

meeting ASTM C-33.” Rationale: Provide a consistent and unambiguous sand specification. ASTM C-33 is commonly available throughout Wyoming.

- S) Section 10: Consider eliminating section 12 and moving its contents to Section 10. Also consider changing the title of Section 10 to “Uniform Effluent Distribution”. The rationale is that uniform effluent distribution is the goal of d-boxes, laterals as well as pressure distribution within the drainfield and gravity distribution within the drainfield. Presby AES has been shown to provide uniform linear distribution of effluent by gravity and therefore should be included.
- T) Section 11 a (i): The term “soil” should be modified to include fill and/or sand to make it consistent with Section 3 (a) and 3 (c) definitions.
- U) Section 11 a (iv): The depth of cover specification should make it clear that 1 ft of total cover over the top of the distribution device (perforated pipe, passive aerobic treatment pipe or chamber). A related question: Should depth of cover be specified for drip systems as well?
- V) Section 11 (vii): Consider inserting the following as the first sentence: “When proprietary trench or bed distribution technology, approved by WDEQ, is used in lieu of perforated pipe and aggregate, it shall be installed in conformance with the manufacturer recommendations.” This will provide all approved technologies equal equal opportunity within the statutes. Otherwise WDEQ could be viewed as favoring proprietary chamber technology over all others, as demonstrated in Sections 11 (viii) and (ix) where the chamber manufacturer specifications are allowed to supersede WDEQ pipe/stone drainfield design criteria.
- W) Section 11 (vii) A: Consider rewording this section to read: “The soils shall have percolation rates faster than 90 minutes per inch. Unless otherwise authorized by the technology manufacturer, the bottom of the bed must be level.” In both 2011 and 2013, RockVale submitted extensive data and field test information showing that Presby AES has a comprehensive bed design system that enables sand beds to be installed and operated while meeting 30/30 standards in clay soils up to and exceeding 90 mpi. As well, it has been shown that the Presby AES bed design system accounts for installation with bed slopes ranging from 0% to 25% and on site slopes ranging from 0% up to 30% - all depending on soil type and percolation rate. The word “clay” should be deleted since all soil types contain some fraction of clay and the terms “clay” or “clay soil” are not defined in Section 3.
- X) Section 11 (vii) B: Consider deleting the second sentence of this section. In both 2011 and 2013, RockVale submitted extensive data and field test information showing that Presby AES has a comprehensive bed design system that enables sand beds to be installed and operated while meeting 30/30 standards with laterals installed within 6 inches of the bed sidewall.
- Y) Section 11 (vii) C: Consider deleting this section. In both 2011 and 2013, RockVale submitted extensive data and field test information showing that Presby AES has a comprehensive bed design system that enables sand beds to be installed and operated while meeting 30/30 standards in bed width exceeding 25 ft and at bed spacing distances that are dependent on soil type.
- Z) Section (viii): Consider revising the first sentence to read: “When proprietary trench or bed distribution technology, approved by WDEQ, is used in lieu of perforated pipe and aggregate, it shall be installed in conformance with the manufacturer recommendations.” This will provide all approved technologies equal opportunity within the statutes.
- AA) Section (ix): Consider revising the first sentence to read: “When proprietary trench or bed distribution technology, approved by WDEQ, is used in lieu of perforated pipe and aggregate, it shall be installed in conformance with the manufacturer recommendations.” This will provide all approved technologies equal treatment in the statutes.
- BB) Section (x): Consider revising the first sentence to read: “When proprietary trench or bed distribution technology, approved by WDEQ, is used in lieu of perforated pipe and aggregate, it

shall be installed in conformance with the manufacturer recommendations.” This will provide all approved technologies equal treatment in the statutes. In both 2011 and 2013, RockVale submitted extensive data and field test information showing that Presby AES has a comprehensive bed design system that enables sand beds to be installed and operated while meeting 30/30 standards in serial flow arrangement and on site slopes up to 30% and bed slopes up to 25%.

- CC) Section (ix): Section 11 (vii) unjustifiably sets prohibitive limits on bed systems while Section 11 (viii) and (ix) provide specific and favorable provisions for chamber technology.
- DD) Section 11 (b): Since RockVale offers a proven proprietary online design spreadsheet for Presby AES drainfield systems and its design process may be certified by a third-party PE rather than a WDEQ PE, this provision should either be modified to provide equal opportunity to all WDEQ approved technologies or it should be eliminated in view of it potentially being viewed as favoring only WDEQ PE certified technologies.
- EE) Section 12: Consider eliminating section 12 and moving its contents to Section 10. The rationale is that uniform effluent distribution is the goal of d-boxes, laterals, pressure distribution within the drainfield and gravity distribution within the drainfield. Presby AES has been shown to provide uniform distribution within the drainfield via gravity. While Presby AES can be used to house pressure dose manifolds similar to chambers, the ability of AES to provide uniform distribution by gravity is an advantage to residents and business with regard to system cost, power consumption and reliability. WDEQ may desire to go on record as actively considering technologies and methods that increase small wastewater system reliability while reducing cost to residents, relative to standard pressure distribution systems.
- FF) Section 12 a: Consider inserting the following as the first sentence: “When proprietary trench or bed distribution technology, approved by WDEQ, is used in lieu of perforated pipe and aggregate, it shall be installed in conformance with the manufacturer recommendations.”
- GG) Section 12 (c): Since RockVale offers a proven proprietary online design spreadsheet for Presby AES drainfield systems and its design process may be certified by a third-party PE rather than a WDEQ PE, this provision should either be modified to provide equal opportunity to all WDEQ approved technologies or it should be eliminated in view of it potentially being viewed as favoring only WDEQ PE certified technologies.
- HH) Section 13: Consider inserting the following as the second sentence: “When proprietary trench or bed distribution technology, approved by WDEQ, is used in lieu of perforated pipe and aggregate, it shall be installed in conformance with the manufacturer recommendations.”
- II) Section 13 (d): Since RockVale offers a proven proprietary online design spreadsheet for Presby AES drainfield systems and its design process may be certified by a third-party PE rather than a WDEQ PE, this provision should either be modified to provide equal opportunity to all WDEQ approved technologies or it should be eliminated in view of it potentially being viewed as favoring only WDEQ PE certified technologies.

End of comments.